

STUDIJA OCIJENE I PRAĆENJA UČINKOVITOSTI PROVEDBE PROJEKTA
IZGRADNJE KANALIZACIJSKE MREŽE I ANALIZA UČINKOVITOSTI RADA UREĐAJA
ZA PROČIŠĆAVANJE OTPADNIH VODA U GRADU POREČU – STUDIJA POREČ

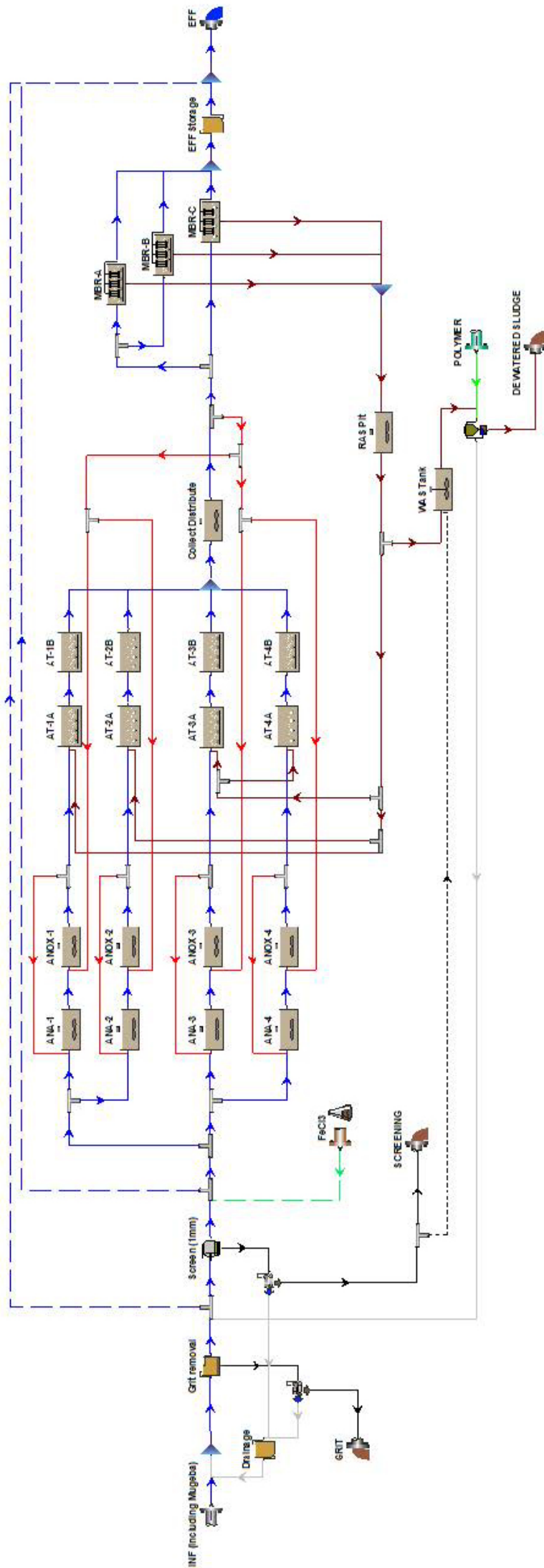

IZVJEŠĆE 5a

Modeliranje UPOV-a na osnovu detaljnih projekata: UPOV Poreč Jug

lipanj 2021



STUDIJA OCJENE I PRAĆENJA UČINKOVITOSTI PROVEDBE PROJEKTA IZGRADNJE
KANALIZACIJSKE MREŽE I ANALIZA UČINKOVITOSTI RADA UREĐAJA ZA
PROČIŠĆAVANJE OTPADNIH VODA U GRADU POREČU – **STUDIJA POREČ**

IZVJEŠĆE 5 – dio 1/4

Modeliranje UPOV-a na osnovu detaljnih projekata: UPOV Poreč Jug

Lipanj 2021

Zajednica izvršitelja



Naručitelj



Krajnji korisnik



STUDIJA OCJENE I PRAĆENJA UČINKOVITOSTI PROVEDBE PROJEKTA IZGRADNJE
KANALIZACIJSKE MREŽE I ANALIZA UČINKOVITOSTI RADA UREĐAJA ZA
PROČIŠĆAVANJE OTPADNIH VODA U GRADU POREČU – **STUDIJA POREČ**

IZVJEŠĆE 5 – dio 1/4

Modeliranje UPOV-a na osnovu detaljnih projekata: UPOV Poreč Jug

27. lipnja 2021

mr.sc. Božidar Deduš, dipl. ing.
Ovlaštenik Zajednice izvršitelja
Proning DHI d.o.o.

23. lipnja 2021

United Nations
Institute for
Water Education
under the auspices
of UNESCO
IHE
DELFT

prof. dr. sc. Dario Brdjanovic, dipl. ing.
Voditelj stručnog tima
IHE Delft

Evaluation and efficiency monitoring of the new implemented sewage network and wastewater treatment construction in the larger city of Poreč.

Report 5.1 - Static modelling of the detailed design:
Winter and summer conditions.

WWTP Poreč-South

2021 07 18

Definitive Concept



Lagen-Aarleseweg 13
 NL – 5425 PD De Mortel (NB)
 The Netherlands

Phone: + 31 (0) 6 24842234

Mail: meijer@asmdesign.nl

Web: www.asmdesign.nl

IBAN: NL66 RABO 0113 1888 46

SWIFT: RABONL2U

VAT: NL-175272530B01

Business registration: 30206848

Responsibility

Project Title	: Evaluation and efficiency monitoring of the new implemented sewage network and wastewater treatment construction in the larger city of Poreč.
Working Title	: Report 5.1 – WWTP Poreč-South – Static modelling of the detailed design: Winter and summer conditions.
Project Description:	: Study of the environmental impact as the result of upgrading and operation of the wastewater system of the larger city of Poreč on coastal sea water quality. Integrated evaluation of the sewer system, wastewater treatment systems, coastal discharge, and sea water quality based on modelling tools. Static modelling of the detailed design based on 2019 influent data measured under summer and winter conditions.
Document number	: ASM-20210718-RAP103
Status	: Definitive Concept
Date	: 2021 07 18
Responsible Author(s)	: Sebastiaan. C.F. Meijer Ph.D. MSc., ASM Design B.V.
e-mail address	: meijer@asmdesign.nl
To	: Hrvatske Vode, Ulica grada Vukovara 220, 10000 Zagreb, Croatia
e-mail	:



Content

Content	3
1 Management summary	6
1.1 Introduction	6
1.2 Project goals	7
1.3 Reader	7
1.4 General conclusions	7
1.5 Recommendation.....	8
2 Introduction	9
2.1 Introduction	9
2.2 Goal of the Poreč modelling project	10
2.3 Goal of the inception report	11
2.4 History and context	11
2.5 Methods, reporting requirements and documentation.....	12
2.6 Modelling the effects of project Poreč	12
3 General setup of the study and scenarios	14
3.1 Main tasks required of the Consultant.	14
3.2 Identification of the main scenarios	14
3.3 Modelling sewage catchment areas.....	15
3.4 Modelling WWTP operation.....	16
3.5 Relation to seawater quality modelling.....	16
3.6 Scenario study on WWTP operation and effluent quality	17
3.7 Extreme effluent discharge events	18
4 General project planning	19
4.1 Steps in the project execution and planning of WWTP modelling:.....	19
4.2 Project window and follow-up.....	19
5 Methods and Guidelines.....	21



5.1	Introduction	21
5.2	Modeling software	22
5.3	Stepwise design approach	22
5.4	Structure of the guidelines protocol	23
6	Process Description	28
6.1	Location.....	28
6.2	Plant Facilities.....	28
6.3	Flow scheme	29
6.4	Influent flow and loads.....	29
6.5	Inlet pumping station	30
6.6	Pre-treatment	30
6.7	Micro-screening	31
6.8	Biological treatment	31
6.9	Anaerobic phase	32
6.10	Anoxic tank	33
6.11	Aerobic tank	34
6.12	Aeration.....	34
6.13	Membrane filtering.....	36
6.14	Storage and disinfection of treated water for technical purposes	38
6.15	Excess sludge	38
6.16	Dewatering	38
6.17	Effluent quality requirement	39
6.18	Drainage collection	40
7	Influent flow and quality measurements	41
7.1	Influent sampling and measurements.....	41
7.2	Influent flow.....	42
7.3	Time average versus flow-proportional concentration	42
7.4	Influent concentration	43
7.5	Average influent loads winter and summer period	44
8	BioWin Influent characterization.....	46
8.1	Influent (BOD and COD) Wastewater Fractions.....	46



8.2	Calculating BioWin influent fractions from influent measurements	48
9	Model design reconstruction 2019 measured influent load.	55
9.1	BioWin model setup.....	55
9.2	Model considerations	56
9.3	Model results.....	57
9.4	Conclusions on the model results.....	60
10	Conclusions and recommendations.....	61
10.1	General conclusions	61
10.2	Recommendation.....	61
	Appendix 1. Project overview and planning.....	62
	Appendix 2. Plant Design Layout	63
	Appendix 3. Layout Activated Sludge System	64
	Appendix 4. BioWin Layout.....	65
	Appendix 5. Mass Balance: Design	67
	Appendix 6. Influent Concentrations Winter & Summer	68
	Appendix 7. Influent Loads Winter & Summer.....	69
	Appendix 8. Design Loading 2045 Prognosis.....	70
	Appendix 9. BioWin Model Influent Specification – Summer.....	71
	Appendix 10. BioWin Model Influent Specification – Winter.....	76
	Appendix 11: BioWin user and configuration data – Winter Load	81
	Appendix 12: BioWin user and configuration data – Summer Load.....	125



1 Management summary

1.1 Introduction

The infrastructural investment “Sewerage and Wastewater Treatment Plants of City of Poreč”– Project Poreč, co-funded by European Union, is one of the largest investments in the public sector in Republic of Croatia. It involves rehabilitation and extension of the existing sewerage system and construction of four new wastewater treatment plants (WWTPs). The goal is to better protect the environment in and around the Poreč coastal area. Complementary a project is developed titled “Integrated Modelling of Wastewater Infrastructure System of City of Poreč” – Modelling Project. This project is an integrated environmental assessment to obtain a better understanding of the environmental impact of the system performance which is evaluated under range of operational conditions. A scenario study is developed using state-of-the-art (modelling) tools and methods which allows a holistic assessment of the wastewater system. The results of this study are in assistance of future operations and wastewater management in the region and used to elevate knowledge and professional skills of local water sector professionals.

The Modelling Project consists of 4 main components, namely:

- Part 1: Modelling the sewage collecting and transport system of City of Poreč,
- Part 2: Modelling of operation and performance of 4 WWTPs of City of Poreč,
- Part 3: Model assessment impact offshore outlets on aquatic water quality,
- Part 4: Establishment of the experimental laboratory setup for monitoring and optimization of wastewater management and operation.

Including a training is organized to extend the capacity of water professionals in the use of wastewater modelling for future assessments.

The Modelling project has a holistic system approach covering collection, processing, and aquatic discharge of wastewater, the interrelation between the different wastewater systems and impact on the environment, public health, and coastal seawater quality.

Several scenarios are calculated to explore the impact of Project Poreč on the previous mentioned factors and to establish the best methods for management of the wastewater systems from an integrated perspective.

Modelling is used to demonstrate how upgrade of the Poreč wastewater system improves the environment. Further insight is developed in the overall interaction of the sub-systems on seawater quality. Knowledge is developed on how to operate and optimize the different wastewater systems, with the best overall results.



1.2 Project goals

The overall objective of the Poreč modelling project is to demonstrate how upgrading the total wastewater system improves the sea water quality in the Poreč coastal region. Therefore, the total wastewater system is modelled consisting of several sub-systems. By modelling the WWTP under different (extreme) conditions it is investigated how effluent discharge load and quality will affect the sea water quality. For each studied scenario, effluent concentration and flow profiles are calculated. These data are subsequently used as input for sea water quality modelling from which the environmental impact is calculated.

This is the first report in this series. It is the inception report and static modelling of the detailed design. Relevant data for the WWTP modelling and scenario study is collected, organized, processes for modelling and a static model is reported. The methods used for this research are explained and a general planning is made for the execution of the work.

1.3 Reader

This report concerns Modelling project Part 2: Modelling of operation and performance of 4 WWTPs of City of Poreč. Each WWTP is modelled and reported separately. Modelling project Part 2 is developed in four steps, one report per step for each individual WWTP.

- Step 1: Static WWTP modeling based on the detailed design. In the total project this is report number 5, consisting of 4 sub-reports one for each WWTP (report number 5.1 to 5.4).
- Step 2: Dynamic WWTP modeling based on dynamic winter and summer influent measurements. In the total project this is report number 6, consisting of 4 sub-reports one for each WWTP (report number 6.1 to 6.4).
- Step 3: Analysis of operational WWTP scenarios. This report takes the results of the previous studies, and a series of operational scenarios are developed and quantified on the coastal discharge loads and concentrations (report number 7).
- Step 4: Model validation based on operational measurements. In the total project this is report number 8, consisting of 4 sub-reports one for each WWTP (report number 8.1 to 8.4).

This sub-report presents the gathering and organization of information and static modelling of WWTP Poreč-South. The data for this study are measured in the winter and summer of 2019. One week in each season, during 7-days 24-hours, per WWTP location 84 samples are collected in the untreated sewage. In each sample we measured 16 wastewater parameters including flow (chapter 4), concentrations (chapter 5) and loads (chapter 6).

1.4 General conclusions

- From this study it is concluded that all relevant information is available to execute the study, including plant design data, process flow diagrams and influent data.
- In this study, data is collected and organized and made available in spreadsheets for further processing.
- Influent data is measured and suitable for modelling and design calculations.



- All data required to calculate the model influent characterization is available. Influent data is processed for modelling according to the influent specification method.
- A static model is developed using BioWin software based on the detailed design and measured average influent data.
- The model is completely based on default BioWin parameter setting and information from the detailed design.
- Static simulation results show that the model performs according to the effluent and design requirements both under winter and summer conditions.

1.5 Recommendation

- This study can be followed up by a dynamic evaluation. It is recommended to proceed with further development of the WWTP model taking in account the above conclusions.



2 Introduction

2.1 Introduction

The infrastructural investment “Sewerage and Wastewater Treatment Plants of City of Poreč”– Project Poreč, co-funded by European Union, is one of the largest investments in the public sector in Republic of Croatia. It involves rehabilitation and extension of the existing sewerage system and construction of four new wastewater treatment plants (WWTPs) to better protect the environment in and around the Poreč coastal area. All new constructed WWTPs employ biological treatment with activated sludge and solid/liquid separation using membrane bioreactor technology (MBR).

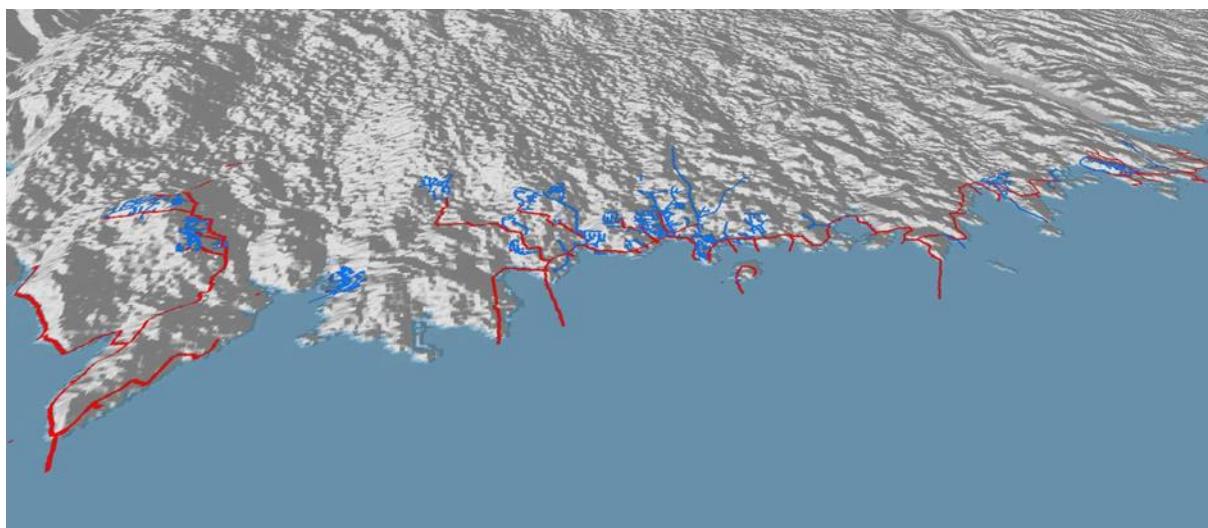

Figure 1. Wastewater transportation, treatment, and discharge in the Larger area of the City of Poreč based on GIS data.

The area surrounding Poreč is a popular tourist destination attracting more than half a million of tourist each summer. As a result, in the summer the amount of wastewater is considerably higher than the rest of the year. The peak loading falls together with the moment the health risk for the population is the largest due to increased public bathing. Simultaneously, the environmental pollution risk is at its highest due to warm seawater conditions and the increased potential for algae bloom (eutrophication). With the upgraded wastewater system, the treated wastewater needs to be safely discharged in the Adriatic Sea under all conditions. Therefore, the new plants are designed and operated adjusted to all seasonal variations in temperature, flow, and load. All four new treatment systems are membrane bioreactors (MBRs) which are typically capable of high treatment performance at a wide span of hydraulic and pollution loads. By using membranes, pathogenic bacteria and most viruses are removed from the effluent. This provides the possibility for safe



effluent reuse. The plants are constructed as parallel lanes which, depending on the required capacity, can be taken in or out of operation.

The upgraded wastewater system of Poreč uses treated effluent for irrigation of parks, agriculture land and golf courses, street washing, firefighting, flushing sewerage, maintenance purposes, and other societal needs. When the effluent quantity surpasses the needs for reuse, the surplus effluent is directed to the Adriatic Sea through offshore outlets. Therefore, improved effluent standards are adopted. Still, in exceptional cases (emergency, high rainfall, large maintenance) bypass of partly treated sewage could be required. This can temporarily cause effluent of lesser quality to be redirected to the sea. It is investigated how these improvements will affect the seawater quality. The overall expected result of Project Poreč is a significant improvement of seawater quality, a reduced risk for the public health, improved environmental safety and reduction of water consumption due to effluent reuse. To better understand how seawater quality is affected, an integrated modelling study is performed where the sewage system (Part 1), 4 wastewater treatment plants (Part 2) and the combined Adriatic discharge is simulated using a seawater quality model (Part 3).

Table 1. Variation of population and wastewater load winter and tourist season.

WWTP Poreč-South - Data for Poreč-South WWTP sizing				
	Population (PE)	Tourist Overnights Average		Non-Households
Months	2011	2009-2011	2009-2011 (m3/month)	2009-2011 (m3/month) ²
1	4590	7700	14400	15600
2	4590	6900	13700	15000
3	4590	16500	12700	17400
4	4590	76500	15800	42900
5	4590	191900	21300	98100
6	4590	393900	25500	140600
7	4590	676200	33500	208700
8	4590	732200	37200	215600
9	4590	373700	35600	150200
10	4590	51400	16300	49100
11	4590	4800	13700	15800
12	4590	11400	11500	10200
Estimated growth of tourist overnights from 2011 to 2045				0,15
Permanent population 2045				5578

2.2 Goal of the Poreč modelling project

The overall objective of the Poreč modelling project is to demonstrate how upgrading the total wastewater system improves the sea water quality in the Poreč costal region. Therefore, the total wastewater system is modelled consisting of several sub-systems. By modelling the WWTP under different (extreme) conditions it is investigated how effluent discharge load and quality will affect the sea water quality. For each studied scenario,



effluent concentration and flow profiles are calculated. These data are subsequently used as input for sea water quality modelling from which the environmental impact is calculated.

2.3 Goal of the inception report

The goal of the inception report is to collect and report all relevant (raw) data for the WWTP modelling and scenario study. The methods that are applied to conduct the study are explained based on a previously developed protocol. In this protocol the inception report is the first phase of development. No new information is produced in this phase. The general outline of the scenario study is determined and thereby the boundaries of the study are determined. This study focuses on operational aspects of the four WWTPs. The input is raw wastewater from the different sewage system. The output is effluent of a certain quality and quantity fed to the coastal seawater system. When the actual scenario study is further developed (the final phase 4) variants may be added based on new insights from developed information. In total four inception reports are produced, one for each WWTP. Relevant information is gathered from original plant design reports. Process diagrams are used to build the preliminary model setup in BioWin software. Influent data measured during high and low season is organized in the appropriate modelling format for static and dynamic calculations. Average loads and flow weighed concentrations are calculated from measured time series. It is checked if all necessary data is available to develop the following steps of the study.

2.4 History and context

The sewage network of Poreč is divided in 5 sub-systems. The original treatment of sewage was limited to mechanical pretreatment and chemical enhanced solids removal before discharge to the Adriatic Sea. Besides the negative impact on the aquatic environment, such practice has influence on public health and tourism in the region. To address the increasing requirements for effluent discharge quality and to improve and protect the quality of coastal waters of Poreč, the Project Poreč was established. This was done under the framework of IPA Program Environment 2017-2013, Priority Line 2 "Protection of Croatian Water Resources by Improving Water Supply and Integrated Wastewater Management System". The project co-financing by EU is approved on 01-07-2013 and was originally planned to be completed by the end of 2017. The project includes reconstruction of 23 km of sewerage network (13 km gravity sewers and 10 km pressurized mains) and new 26 pumping stations, construction of 13 km of main collectors to transport sewage to new WWTPs, reconstruction of the offshore outlets, refurbishing existing 31 pumping stations and building 7 new stations equipped with automation and telemetry. In addition, 63 km of new sewage network (56.5 km gravity and 6.5 km pressurized pipes) are constructed to increase service coverage, and 26 new pumping stations are constructed with automation and telemetry allowing an integrated operation and monitoring system. Finally, the project includes construction of 4 new WWTPs based on activated sludge technology with membrane separation of sludge and water (MBRs), effluent reuse, and centralized solar treatment (Poreč North) and composting of waste sludge (Košamba sanitary landfill). The 4 new plants are: Lanterna (30,000 PE), Poreč North (37,000 PE), Poreč South (48,000 PE) and Vrsar (22,500 PE), with total capacity of 137,500 PE.



After completion of Project Poreč the existing sewerage system (165 km and 54 pumping stations) will be partially rehabilitated and extended with an additional 62 km of pipes and 26 pumping stations which increases the service coverage from 63% to more than 90% by connecting 28 new agglomerations and 6,300 inhabitants.

2.5 Methods, reporting requirements and documentation.

This report is originally written in English language. A management summary is translated in Croatian. The document is delivered in 4 phases, each report being the basis of the following. In each phase, 4 reports are delivered describing the individual WWTPs. The goal of the final series of reports (phase 4) is to document four WWTP modelling studies including the scenario calculations. The reports will include relevant aspects of organization, planning, data-collection, design calculations, modelling, simulation, field work and measurement campaign. The study is reported such that the results can be reproduced from the documentation. Therefore, all applied data is attached to the annex in the form of tables and figures. The (calculation) models, (modelling) software and plant assessment methods which are used in this study are published in (scientific) literature. Protocols are used for practical fieldwork and measurement campaigns. The methodology can be used for future plant assessment in similar projects. Part of the project is transferring the knowhow, practical methods, and training of staff and personal in the use of modelling software. The project documentation thereby serves as teaching material.

2.6 Modelling the effects of project Poreč

While the project Poreč focuses on rehabilitation of the existing and construction of new sewage collection, transport and treatment infrastructure and waste sludge management, a complementary project is developed entitled “Integrated Modelling of Wastewater Infrastructure System of City of Poreč” – Modelling Project. This integrated environmental assessment is established to better understand the system performance and operational conditions and under range of present and future scenarios. Therefore state-of-the-art (modelling) tools and methods for assessment are developed which are used to elevate knowledge and professional skills of local water sector professionals and assist in future operations and wastewater management in the region. The Modelling Project consists of 4 main components, namely:

- Part 1: Modelling the sewage system of City of Poreč,
- Part 2: Modelling of operation and performance of 4 WWTPs of City of Poreč,
- Part 3: Model assessment impact offshore outlets on aquatic water quality,
- Part 4: Establishment of the experimental laboratory setup for monitoring and optimization of wastewater management and operation.

With completion of Project Poreč, the existing sewerage system (165 km and 54 pumping stations) will partially be rehabilitated and extended by additional 62 km of network and 26 pumping stations. This increases the service coverage from existing 63% to more than 90% by connecting 28 new agglomerations and 6,300 more inhabitants. The complementary Modelling Project will integrate information regarding the sewerage system; non-rehabilitated, rehabilitated and newly constructed covering the total planned extension. The



project has a holistic system approach covering collection, processing, and aquatic discharge of wastewater, the interrelation between the different wastewater systems and impact on the environment, public health, and coastal seawater quality.

Several scenarios are calculated, some provided by the Project Poreč and several others as developed and summarized in Table 1, to explore the impact of Project Poreč on the previous mentioned factors and to establish the best methods for management of the wastewater systems from an integrated perspective.

Modelling is used in a system approach to demonstrate how upgrade of the Poreč wastewater system improves the environment. Moreover, further insight is developed in the overall interaction of the sub-systems on seawater quality and knowledge is developed on how to operate and optimize the different wastewater systems with the best overall results.



3 General setup of the study and scenarios

3.1 Main tasks required of the Consultant.

1. Collecting data that are available and necessary for modelling the 4 sub-wastewater catchment areas in the Poreč area.
2. Build a model of the sewerage network using a suitable software package including transport models of the sewage system, WWTP models and model of the seawater quality of the total Poreč coastal area.
3. Performance of model-based computations of all 4 sub-systems for the scenarios listed in Table 2 and using data collected under point 1.
4. Calibration and validation of all model results based on two selected operational periods (High and Low season). Calibration is to be undertaken after completion of the sewerage system rehabilitation and extension as part of Project Poreč (estimated 2022).
5. In addition to the activities under step 1, step 4 may include a measuring and sampling campaign.

3.2 Identification of the main scenarios

The basic framework for the scenario study is as follows:

- Four sewage catchment areas are modelled, each consisting of three sub-systems: Sewerage network, wastewater treatment (WWTP) and the coastal seawater quality around Poreč as one overarching system.
- The coastal seawater quality is the common sub-system for all four sewage catchment areas and modelled based on the output of the combined output of the four wastewater treatment systems.
- Two main seasonal scenarios are considered: Summer and winter which overlaps with touristic high season and low season.
- Two main loading scenarios are considered: High loading during the tourist season and low loading the rest of the year,
- Regarding the newly realized WWTPs, two scenarios are considered: With the new WWTPs in operation and without (scenarios “NOT”).
- In time, there is the starting situation without any tertiary treatment of wastewater (measured in 2019), a time where all wastewater is treated (estimated 2022) and a time in the future when the design capacity will be reached (2040).
- Regarding WWTP operations, two scenarios are studied: With 100% reuse of treated effluent (scenario “TER”) and with emergency discharge of treated effluent into the sea (scenario “OED”).



Additionally, several worst-case scenarios are calculated affecting seawater quality. An example is an emergency discharge when a plant is out of operation during high season. These scenarios are modelled to study the effect on such events on the seawater quality.

Table 2. Identification of the main scenarios

Sc.	Season	TER/OED/NOT	Flow/Load	Sewerage	WWTP	Sea	Comment	
S1	Summer	TER	Max	■	■	×	No need to model sea due to 100% reuse of the effluent	
S2		OED				■	■	Low risk impact on the sea due to functioning of WWTP with UF MBR
S3		NOT				×	■ ¹	High risk on the sea due to no treatment and max flow/load (scenarios S3.1-S3.5)
S4		TER/OED				Min	■	■
W1	Winter	TER	Max	■	■	×	No need to model sea due to 100% reuse of the effluent	
W2		OED				■	■	Low risk impact on the sea due to functioning of WWTP with UF MBR
W3		NOT				×	■	Medium risk impact on the sea due to less flow/load and winter – no bathing
W4		TER/OED				Min	■	■

TER: Treated Effluent Reuse

OED: Offshore Emergency Discharge

NOT: No Treatment (Note¹: Seawater modelling in this high risk case will examine 4 sub-scenarios: S3.1 – S3.4, one WWTP out of operation at the time, and one worst case scenario: S3.5 with all 4 WWTP out of operation simultaneously, with optional dynamic simulation of day/night conditions, depending on data available).

Where there is 100% re-use of wastewater (Table 2, TER), there is no need to model seawater quality as there will be no discharge to the Adriatic Sea. In the scenarios NOT, there is no treatment of wastewater and no need for WWTP modelling.

3.3 Modelling sewage catchment areas

The study starts with modelling 4 sewage catchment areas. Therefore, hydraulic data is collected, and a hydraulic model is made of the total sewage network using dedicated sewage modeling software. There are two operational conditions calculated: Summer high season and the rest of the year being low season including minimum and maximum loading conditions. Calibration and validation of the calculation models can be done as soon as operational data is available after completion of sewage system rehabilitation and extension as part of the larger Project Poreč. This may include a measuring and sampling campaign. The model will be part of the knowledge transfer and local water professionals will be trained so they can independently be used for future operational evaluation.



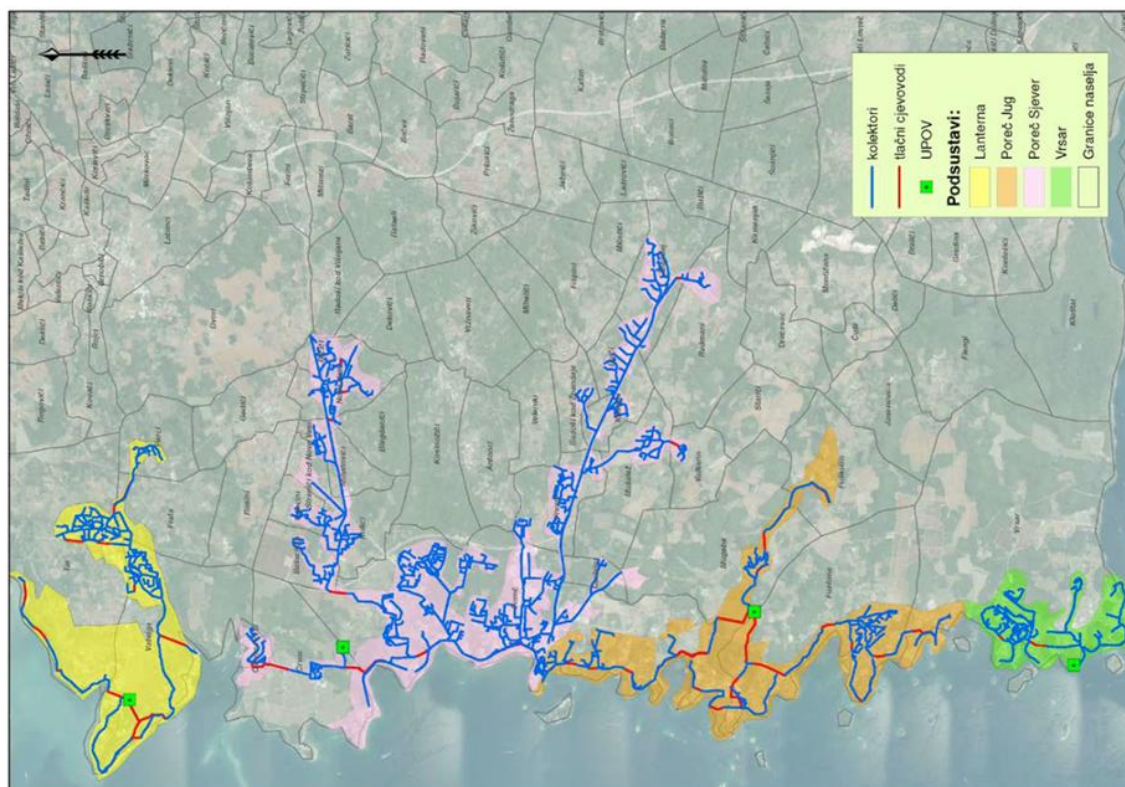

Figure 2. Model of the sewage transportation system of the larger area of Poreč

3.4 Modelling WWTP operation

At the starting point of Project Poreč, six WWTPs with a total capacity of approximately 100,000 PE are in operation. The treatment method is mainly mechanical with addition of some chemical treatment. The effluent is discharged through offshore outlets (500-1,000 m) at minimum water depth of 25 m. Project Poreč foresees realization of 4 new WWTPs with a total capacity of 137,000 PE with tertiary level of treatment: Mechanical pre-treatment, N and P removing activated sludge process, membrane bioreactor (MBR) and post-treatment water reuse. Three of the four new plants are relocated land inwards, while the new plant in Vrsar is constructed close to the existing coastal treatment location. All plants employ a similar sewage treatment process: Activated sludge with MBR separation. The plant details are all obtained from Project Poreč WWTP design documentation.

3.5 Relation to seawater quality modelling

The output of the WWTP modelling scenarios is used as starting point for surface water pollution modelling and a health and environmental impact assessment (Project Part 3). The sewage and WWTP modelling are developed to acquire long and short-term predictions regarding WWTP treatment performance (daily, seasonally, yearly and design horizon). The goal of seawater quality modelling Part 3 is to understand and predict the influence of extreme effluent discharge events, which are expected to have the largest impact on seawater quality, public health, and environmental safety. The 4 WWTPs will therefore be simulated based on minimum, average and peak performance under varying conditions (e.g., winter and summer, storm weather, seasonal loading variations, industrial activity, etc.). The study includes an analysis of extreme discharge events and will predict



the frequency and magnitude of these occurrences based on modelling and expert judgement. Environmental risks related to these extreme events are addressed in the environmental impact study Project Part 3.

3.6 Scenario study on WWTP operation and effluent quality

The operational performance of each of the 4 WWTPs is modelled and simulated under varying conditions including several worst-case scenarios. Therefore 4 separate WWTP models are prepared based on design information from Project Poreč. The input data on WWTP influent quantity (flows) and quality (loads and concentrations) are obtained from sewage system calculations performed in Part 1 of this project. These data are supported by a measurement campaign of the four sewage systems. For each of the 4 WWTP modelling scenarios the following variables are taken in account:

- Measured sewage quality and quantity,
- Sewage modelling results of Project Part 1,
- Prognosis loading up to 2040,
- Frequency and loading rate of rain weather events (RWF),
- Yearly minimum, maximum, and average influent loading (Q365),
- Daily minimum, maximum, and average influent loading (Q24),
- Yearly minimum, maximum, and average sewage temperature (T365),
- Other seasonal conditions (e.g., tourism and industrial activity).

The 4 WWTP performance scenarios are simulated up to the 2040 prognosis design capacity. Modelling variations of the influent (daily and yearly), temperature (yearly) and the increased loading prognosis up to the year 2040 is done using a static and dynamic modelling approach. Table 3 shows the general planning of scenario calculations.

Table 3. General planning of modelling scenarios

General planning of scenario calculations						
Scenario	Phase	Period	Season	Flow/loading	Development	Type of treatment
S1	1	2019	Winter	Low	Before upgrade	No tertiary treatment
S2	1	2019	Winter	High	Before upgrade	No tertiary treatment
S3	1	2019	Summer	Low	Before upgrade	No tertiary treatment
S4	1	2019	Summer	High	Before upgrade	No tertiary treatment
S5	2	2022	Winter	Low	After upgrade	Tertiary treatment
S6	2	2022	Winter	High	After upgrade	Tertiary treatment
S7	2	2022	Summer	Low	After upgrade	Tertiary treatment
S8	2	2022	Summer	High	After upgrade	Tertiary treatment
S9	3	2045	Winter	Low	At design limit	Tertiary treatment
S10	3	2045	Winter	High	At design limit	Tertiary treatment
S11	3	2045	Summer	Low	At design limit	Tertiary treatment
S12	3	2045	Summer	High	At design limit	Tertiary treatment



During the first phase the WWTPs are not yet operational. In the second phase the plants are built and based on operational WWTP data calibrated models are constructed which are used to simulate all planned scenarios. WWTP models developed in phase 2 are also used in phase 3 to calculate the conditions at the design limits, projected in 2045.

3.7 Extreme effluent discharge events

Besides the 12 scenarios above a series of worst-case scenarios are investigated. These will be calculated as variants of scenarios 1 to 12. Typical extreme operational conditions that could lead to decreased effluent performance are simulated: e.g., combinations of high/low temperature, high/low influent loading, seasonal peak variations, and frequency occurrence of rain weather events. The possible effects on effluent quality outcome are calculated including the applied design safety margins built into the 4 new Project Poreč treatment systems thus obtaining a realistic estimation of possible events.

Based on the evaluation of worst-cases, the seawater model is calculated, and projections are made on the environmental impact.

In general, MBR nano-filtration systems are effective in removing (pathogenic) bacteria and most viruses from effluent. When there is an emergency discharge bacteria and viruses contaminate the seawater, which is a risk for public health. In case of emergency discharge of non- or partially treated sewage nutrients (nitrogen and phosphorus) can have a negative effect on the environment. Both these effects on the seawater are modelled. It is determined by the environmental and health impact and expert judgement which scenarios are chosen as the most extreme conditions.

Seawater modelling in this high-risk case will examine 4 sub-scenarios, one WWTP out of operation at the time, and one worst case scenario with all 4 WWTP out of operation simultaneously. Depending on the available data, dynamic data are used to simulate seawater based on daily peak loading.



4 General project planning

4.1 Steps in the project execution and planning of WWTP modelling:

- Summarizing and ordering required design data for modelling the 4 WWTPs,
- Measuring and organizing actual quality and quantity wastewater data in 4 catchment areas,
- Evaluating the sewage system modelling results Part 1 and retrieving relevant data,
- Setting up and reporting 4 WWTP calculation models,
- Calibrate, validate, and test the WWTP models,
- Calculating main scenarios listed in Table 1,
- Simulating all predetermined worst-case scenarios,
- When required and possible, collection of data of the 4 WWTPs in operation,
- Evaluate effluent quality observing scenarios in Table 1 in terms of its applicability for reuse and/or discharge into Adriatic Sea through existing offshore outlets,
- Train local water professionals on independent use of all developed models and methods,
- Preparation of the final concluding report on all the above.

4.2 Project window and follow-up

The starting situation for the influent load and flow was measured in 2019 under summer and winter conditions. Using this load discharge, the seawater model was calculated. This serves as the baseline for the environmental assessment.

As soon as the WWTPs are operational WWTP modelling can commence. The results are used to assess the impact of offshore outlets on aquatic water quality. Thus, the WWTP modelling report is followed up with a report on modelling aquatic water quality as the result of the new WWTPs in operation.

Based on the calibrated WWTP models a projection is made towards 2045. This also can be calculated on seawater quality.

Separate from the actual operational evaluation several extreme situations will be modelled. Under normal conditions treated effluent will be used for irrigation of parks, agriculture land and golf courses, street washing, firefighting, flushing sewerage for maintenance purposes, and other societal needs. In case that the effluent quantity surpasses the needs for reuse, the surplus is redirected to Adriatic Sea through offshore outlets. The four new MBR nano-filtration systems that are currently built can remove organic material and nutrients up to required effluent standards as well as remove pathogenic bacteria and most viruses. However, in some scenario's emergency discharge events caused by for example extreme rain or temporary operational shortcoming, can contaminate the seawater.



Depending on the conditions this could increase the risk for public health and may contribute to environmental problems like eutrophication due to discharge of macro-nutrients (nitrogen and phosphorus). The possible effects on seawater quality are studied using a model-based approach in Project Part 3 using the results of the WWTP modelling Part 2.



5 Methods and Guidelines

5.1 Introduction

In the execution of this project, modelling guidelines were applied previously developed by Meijer and Brdjanovic (20XX). The general aim of applying a protocol is to reduce the complexity of the modeling project dividing the project into sub-tasks. Seven general phases in the project development are distinguished according to the scheme in Figure 3.

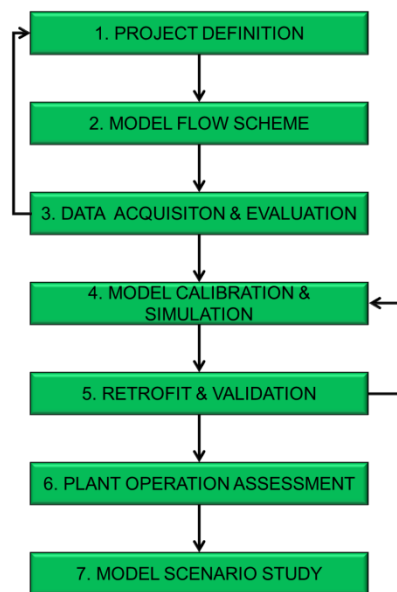

Figure 3. General guidelines structure according to Meijer and Brdjanovic (20XX).

Following the protocol, each of the steps in Figure 3 is broken down into smaller sub-tasks. For each step standardized methods are proposed. This allows better planning of the project and will help to execute the work within given time and budget. The goal of the protocol is to simplify the project while maintaining accuracy of results. The methods have been demonstrated in the Croatian contexts in previous projects concerning modelling of WWTPs Varaždin, Čakovec, Vinkovci, Zagreb and Belišće.

The fundamentals of the protocol originate from the STOWA protocol for activated sludge modeling based on the work of Hulsebeek *et. al.* and Meijer *et. al.* Meijer and Brdjanovic (20XX) further developed a protocol suitable for plant wide modelling taking in account more all aspects of operation then only the activated sludge system. By taking this broader approach, a new extended protocol was developed covering all relevant operational aspects affecting plant performance which is applied in this study.



5.2 Modeling software

For the design/scenario simulations, the BioWin (5.3) WWTP simulation software is used (Envirosim Ltd. at www.envirosim.com). BioWin is state-of-the-art and user friendly intuitively operated Windows based simulation software. The software and applied models are founded on general accepted modeling principles according to international recognized IAWQ standards. The BioWin calculation model integrates the activated sludge models ASM1, ASM2d and ASM3 combined with an anaerobic digestion model (ADM). Additionally, several sub-models are introduced under which including biofilm models, membrane bioreactor models (MBR), pH calculation models and (metal) precipitation reactions.

5.3 Stepwise design approach

A (model) design project generally consists of several successive design calculations. The order of these calculations typically is determined by the type of information that is needed to perform these calculations. For example, to calculate the oxygen requirement for aeration, first influent quality and quantity need to be assessed and then the sludge loading needs to be determined. Therefore, the protocol gives an order to the design tasks, organizing the project in logical successive steps. The protocol starts with a more general approach of determining traditional performance indicators like the sludge loading and SRT. This is followed up by calculating empirical design models, typically static spreadsheet models. Only when this is required for the project and allowed by the accuracy of available information, more detailed models, for example ASM, ADM or plant wide models are applied. While gradually developing towards a more accurate model description, the protocol provides the methodology to obtain all relevant design information with the necessary accuracy to be able to calibrate (adjust model parameters according to measured data) and validate (check the model results according to measured data) the results. Therefore the models themselves are developed in steps and typically first used for static time independent calculations using long term average measurements and only when this can be done satisfactory, more (period and/or operational) specific conditions are studied. Therefore dynamic (time variant) simulations can be applied. However, for most design studies a static approach will be sufficient.

The guidelines are largely generic regarding the type of models and modelling software used. For specific operations additional data may need to be collected and processed. We use BioWin simulation software and some aspects of the protocol, for example the influent characterization is specific to BioWin. BioWin is a full plant simulator which gives the possibility to model the complete wastewater treatment operation and not only the activated sludge performance. Typically, the plant wide approach gives better modelling results and insights for operational improvement. However, building a full plant model requires more time and effort for analysis, data collecting and processing and therefore a larger financial investment. Performing analytical measurements generally can be time consuming and costly. On the other hand, a full plant model generally provides better information for decision making. It allows more precise and efficient design, reduced risks for design failure which may result in costly operational failure. The protocol contains a



planning allowing to estimate additional investments of each design step which need to be weighed against the project goals and risks. And even when not all steps are performed working towards the best results, still good results can be obtained by using the simpler however general reliable empirical design rules (e.g., ATV and STOWA design methods). The more advanced simulations are used complementary to standard design methods to assure the best quality results under different application.

5.4 Structure of the guidelines protocol

The protocol describes the project from the inception up to the final scenario study. Seven phases are distinguished.

- **Inception**: the first step is getting a complete overview of the project. The main goal of the inception phase is to define the problem, define the objectives and to set realistic goals based on a project planning which considers the given time and budget. The project relies on the availability of reliable data. It needs to be investigated in an early phase if these data are available from historical sources and what is the quality. Often, additional measurements are required. This will strongly affect the planning and project budget. The problem definition and research objectives also define the physical boundaries of the process and which process units are included in the study. To make this determination a process flow diagram is drawn up of the WWTP. Also, an inventory is made of the available plant information using checklists. A plant visit is strongly advised. Likely not (all) data can be gathered at this stage. Indicative data samples may be available to get a first impression on what can be expected of the data collection phase. The guidelines provide checklists for information that needs to be gathered in the inception phase. The result of the inception phase is a documentation of the plant inventory including general design data, a sample of available historical (average) operational data, a general overview drawing of the process (process flow diagram) and other specific information that may be of relevance for the project (e.g., contact data, photographs, guidelines, design reports, information about specific operational units, etc.). The inception phase often is planned as a small project on its own. The time invested is approximately 4-5 days including one day of visiting the plant. In short summary inception phase covers the following topics:
 - definition of the project objectives,
 - definition of the process lay out in the process boundaries,
 - collection of initial (estimated) process information,
 - documentation of the project starting points.
- **Initial model construction**: with the initial plant data available, a preliminary WWTP model can be constructed. Based on the specific project goals a choice is made to use the activated sludge model and/or anaerobic digestion model and which software will be used. The model setup also is the basis for a mass balance study. From the process diagram, a (typical simplified) model flow diagram is constructed in the simulation platform. At this stage, no calibration is done. After filling the model with the plant design data and preliminary pump flow data, it will be possible to pre-simulate the



WWTP. Obviously, this will not lead to reliable results, however the goal of this step in the protocol is to get an early indication if the assumed flow scheme is correct, and if the initial provided operational data, at this stage mainly the flow balances, can be fitted in the model. If this is not possible, this indicates that the preliminary data is not correct or reliable. In that case, action should be undertaken to acquire the appropriate information. Testing the data in an early phase of the project provides the possibility for early feedback to the plant operators and the possibility to resolve potential critical problem in an early stage of the project, rather than coming to these conclusions after spending valuable resources working with flawed information. The model construction phase is a desk study which can be performed within 1-2 days. In short summary the model construction phase covers the following topics:

- choice of the simulation platform,
 - constructing the model flow schemes,
 - constructing a non-calibrated model based non verified data,
 - checking information on gross error by running a pre-simulation.
-
- **Data acquisition and evaluation:** In this phase all plant data is acquired necessary for the execution of the study. Historical operational data is collected and checked using mass balance calculations. Typically, collection of operational data focusses on flow measurements, concentration measurements and sludge production numbers. Additional measurements may be acquired to check (specific) operational aspects of the process. Therefore, a measurement plan is developed describing all information on the data to be collected, the period that is measured, the sampling frequency, methods for sampling and preservation and methods for lab analysis. The collected data all fits in a system of mass balances which is derived from the process flow diagram (PDF) drawn up in the inception phase and which determines the boundaries of the study. From the mass balance analysis, it is determined which data are required to calculate the whole system and which data needs to be verified on accuracy. The actual plant sampling is planned and executed in this phase. The outcome of the study is determined by the quality of the data. Logistically, it can take 2 to 3 weeks from the first moment of sampling to the moment the results can be presented for further processing. Good planning of this phase is therefore critical. After all data are collected a second mass balance calculation is performed to verify the accuracy and detect possible errors. The data collection is concluded with a table report of all measured data including accuracy determinations. The dataset is further evaluated by calculating (retrofitting) key performance indicators (KPI) and design parameters like HRT, SRT, sludge loading, oxygen consumption and design models published by STOWA, WEF or ATV. These models are typically available in design spreadsheet calculations. Also, commercial developed spreadsheet models are available for this purpose. When the design calculations result in meaningful numbers within empirical boundaries this is an additional check the dataset is reliable. At this stage in some instances, enough insight may have been obtained to conclude the study and further modelling may not be necessary. When more information is needed in a next phase the design retrofit study is



used to calibrate the model. This is described further on. Depending on the data that needs to be collected/measured, which very much depends on the objectives of the project, the phase of data acquisition and evaluation takes 2 to 4 weeks including a desk study, sampling, and lab analysis. In summary this phase covers the following topics:

- flow balance analysis of the process (using raw model input),
 - designing a measurement campaign,
 - executing sampling and lab analysis,
 - collecting detailed historical operational plant data,
 - performing mass balance calculations,
 - gross error detection on the measured and historical plant data,
 - reporting a checked and balanced data set,
 - empirical design calculations on measured data,
 - initial plant assessment.
- **Model simulation and calibration:** The steps for calibration of the activated sludge model are included in the guidelines by Meijer and Brdjanovic and largely adopted from the STOWA protocol. The verified dataset is used for the model input and verification of the model results. Therefore, the initial model which was developed in the inception phase is further developed. The STOWA protocol gives detailed guidelines how to construct and calibrate the activated sludge model. From the results of the calibrated model, a second design retrofit is calculated (using the previously mentioned spreadsheet models). The time needed to invest in this phase depends on the experience of the modeler. An experienced modeler generally will be able to produce a calibrated model and reports the results within 5 days. If an inexperienced modeler is working in the project 2-3 weeks extra should be reserved for the modeler to get acquainted with the use of the software, the backgrounds of ASM models and model calibration and likely a training on this topic. In short summary this phase covers the following topics:
 - loading the model with checked and balanced input data,
 - steady-state simulation,
 - calibrating the model,
 - reporting the calibrated model results.
- **Model retrofit and validation:** Calibration and validation are very much related and performed hand in hand. As mentioned in the previous section, the results of the calibrated model are used to calculate several design spreadsheets. This serves three main goals; (i) the plant is operationally assessed, (ii) model results are further verified by determining if the model simulation results are within acceptable design boundaries, (iii) it is determined how accurate the model fits to the measured data. The model results are validated by comparing the results using the verified dataset and modeled data. This is done side by side in a single overview table. The accuracy of fit is determined from the deviation of the two calculations. In some cases, the first retrofit



design calculation gives enough insight in the operation to conclude the project. The model study is only advised when the simpler approach is not sufficient. The additional time to fully develop a model should be weighed against the benefits of a much more reliable and detailed plant assessment. In some cases, modelling may be the only way to find and correct operational problems. When for whatever reason measurement data is already available, modelling can be done relative fast. However, this will depend on the experience of the designer and availability of design tools (e.g., readily available design spreadsheet and/or modelling software). Validation of the model results using the retrofit design method is a desk study and will take 2 to 5 days. In short summary this phase covers the following topics:

- preliminary retrofit design calculations based historical plant data,
 - preliminary plant operational assessment based on historical plant data,
 - empirical design calculations based on the results of the calibrated model,
 - presenting together the historical data and model results,
 - validation of the model results.
- **Operational assessment:** At this stage, all gross errors are already detected and corrected in the dataset. However, smaller errors still will be present resulting in differences between the measured and verified dataset and the data from the calibrated model. These (small or larger) differences are used to indicate the accuracy of the design study. The larger the uncertainty, the larger safety factors need to be applied. A safety factor is an additional margin on e.g., proposed volumes and plant capacities securing the design for model uncertainties. In the same assessment it is indicated precisely where the model does not fit the data. From the calibration it is determined which model parameters need to be adjusted out of the typical range to fit the measurements. Based on this information it often can be indicated where operational problems are occurring. When large deviations are found this requires further on-site investigations. Interpreting design data requires a trained eye and includes expert judgment. Assessing the plant performance will take 1-2 days depending on the experience of the designer. In short summary this phase covers the following topics:
 - making an operational plant assessment,
 - reporting the plant assessment.
 - **Scenario study:** Up till this point the operation of the wastewater treatment plant is evaluated based on historical data. In the scenario study, the validated model is applied to predict different conditions (e.g., Increased influent loading, additional reactor volume, different temperature conditions, etc.). The studied scenarios are determined by the project objectives. A general advice is to limit the total number of main scenarios to a maximum of 6. Typically, each scenario will have minor variants. Working with more scenarios will generate large quantities of data which makes processing information and drawing clear conclusions more difficult. It is advised to use a database for larger data sets. It is advised to present scenarios side by side in one overview table. The estimated time investment for a scenario study is 5-8 days.



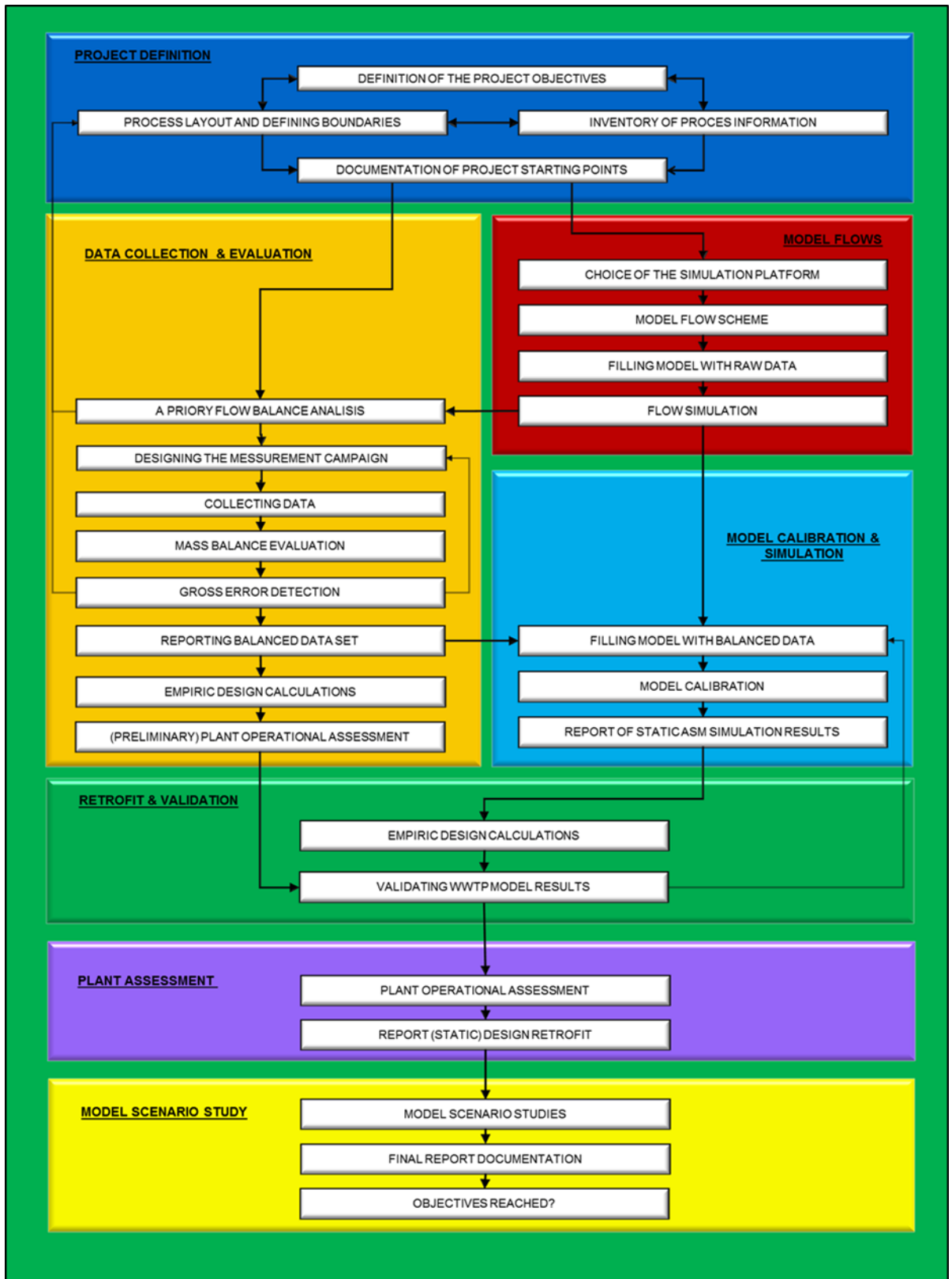

Figure 4. Steps in the modelling guidelines.



6 Process Description

6.1 Location

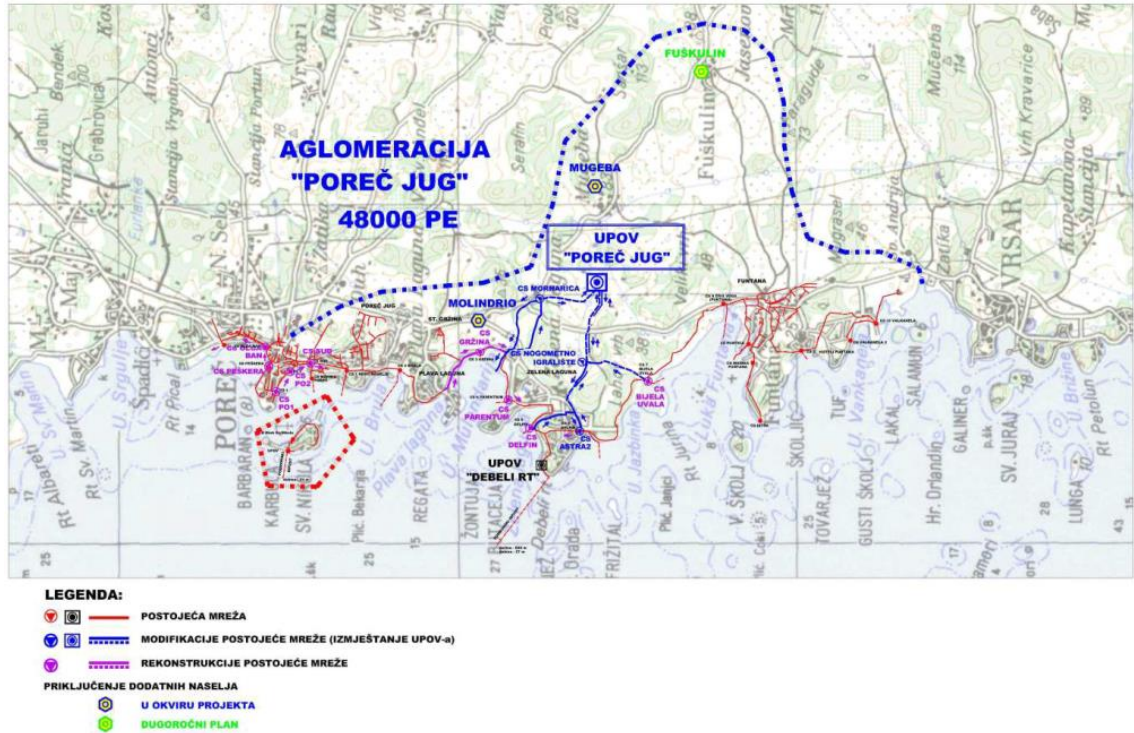

Figure 5. The Poreč-South (Jug) wastewater system.

6.2 Plant Facilities

The WWTP includes the following treatment processes:

- Fine screen with 6 mm spacing,
- Aerated grit and grease removal with sand classifiers (two parallel lines),
- Micro-screen with 1 mm spacing drum screens,
- Influent flow measurement,
- Distribution chamber towards the biological treatment,
- Emergency by-pass connected to salinity control,
- Activated sludge treatment (four lines in parallel),
- Membrane Ultrafiltration reactors (three lines in parallel),
- Effluent flow measurement,
- Treated water storage and disinfection for water reuse,
- Excess sludge extraction and storage,
- Excess sludge storage and mixing tank,
- Sludge dewatering (two parallel lines) and cake disposal,

6.3 Flow scheme

The general process flow scheme is as below.

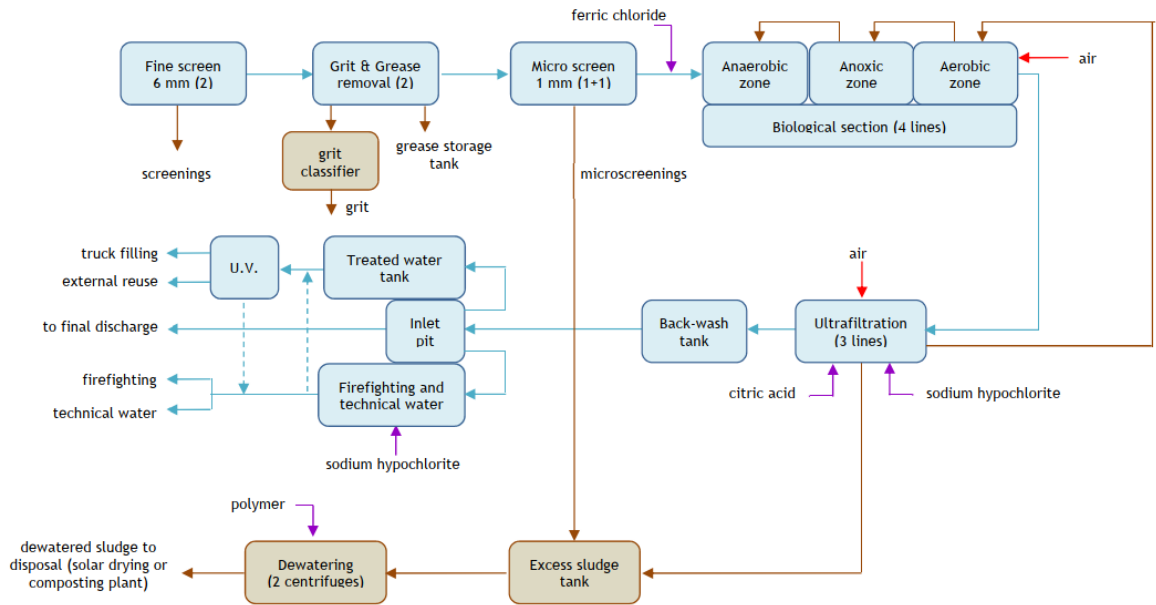

Figure 6. General WWTP Poreč-South Process layout.

6.4 Influent flow and loads.

The influent flow and loads during high and low season are presented in the tables below.

Table 4. Typical flow values of influent wastewater

WWTP Poreč-South - Typical flow values of influent wastewater			
Parameter	Unit	Winter	Summer
Average daily flow	m ³ /day	958	7800
Maximum dry weather flow Peak factor 16/24	m ³ /h	60	490
Infiltration	m ³ /day	487	487
Infiltration Peak factor 4/24	m ³ /h	122	122
Peak daily flow	m ³ /day	1450	8200
Peak hourly flow	m ³ /h	180	610

Table 5. Design daily loads of influent wastewater

WWTP Poreč-South - Design daily loads of influent wastewater			
Parameter	Unit	Winter	Summer
Capacity	PE	8600	48000
BOD ₅	kg/day	516	2880
COD	kg/day	1032	5760
TSS	kg/day	602	3360
VSS/TSS	%	70	70
N-NTK	kg/day	94,6	528
P _t	kg/day	15	86

6.5 Inlet pumping station

Raw water is transported to WWTP Poreč-South through two new pipelines coming from pumping stations Nogometno Igralište and Mornarica and a gravitational sewer coming from the Mugeba settlement.

6.6 Pre-treatment

Mechanical pre-treatment is used to protect the biological process and the membranes, as well as to ensure a minimum treatment level in case of emergency water discharge before the biological section. The pre-treatment consists of fine screening (6 mm), grit and grease removal and micro screening. Pre-treatment main function is to protect downstream equipment, to avoid wear and clogging of pumps, resulting in a reduction of maintenance interventions.

In the pre-treatment, heterogeneous particulate materials, fibers, sand, and grease are removed from the raw wastewater. Pre-treatment does not affect the influent loading of the biology. Measurements of soluble and small particulate materials like COD and TKN are not affected nor is the mass balance. Therefore, operation of the pre-treatment does not need to be modelled in the scenario study.

Fine screen section is dimensioned for the estimated hydraulic peak load for the year 2045, including return flows from drainage system. The total amount of fine screening production is calculated based on a specific production of 110 L/1000 m³ corresponding to 6,5 L/PE/year during high season and 4,5 L/PE/year during low season. Estimated before compaction 0,9 m³/d is produced during high season (summer) and 0,1 m³/d during low season. Expected moisture is between 50% and 65%.

The automatic influent quality measurement and sampler (24 h samples, time and flow proportional) is installed downstream the fine screens.

Wastewaters flows by gravity from the fine screening unit to the grit and grease removal section, consisting of two circular medium bubble aerated tanks in parallel with a diameter of 4 m and volume of 32 m³ each. The effect is elimination of heavy matter (sand and grit) thanks to natural settling and elimination of floating material (grease, oils, floating solids removal) that can have an adverse effect on water treatment. Air bubbles prevent the settling of organic matter and ensure the aeration of the liquid mass, promoting the separation of grease from other agglomerated particles and allowing scum and oils to surface. Sand settles on the bottom where it is extracted. Separated water containing organic material is conveyed back to the treatment line. The total amount of grease production calculated based on 4,2 gCOD/PE/d is estimated < 1 m³/d during summer and 0,16 m³/d during winter. The total amount of grit production based on a specific production of 50 L/1000 m³, is estimated 0,39 m³/d during high season and 0,05 m³/d during low season.



Table 6. Grit and grease removal units

WWTP Poreč-South - Grit and grease removal units			
Parameter	Unit	Winter	Summer
Number of grease removal units	units	2	2
Min. solid matter removal efficiency (solids $\geq 0,2$ mm)	%	97	97
Max. grease removal efficiency (at separator outlet)	mg/L	10	10
Average flow including plant internal backflow	m ³ /h	42	329
Average hydraulic load	m/h	3,4	13
Peak flow including plant internal backflow	m ³ /h	215	645
Peak hydraulic load	m/h	17,1	25,6
Internal diameter per unit	m	4	4
Active surface per unit	m ²	12,6	12,6
Capacity per unit	m ³	32	32
Number of grease storage tanks	units	1	1
Volume grease storage tank	m ³	24	24

6.7 Micro-screening

The grit and grease removal are connected to two parallel micro-screening units with drum screens. Rotary drum sieves with a 1 mm mesh are used to protect the membranes from clogging and reduce maintenance by intercepting hair, fibers, and larger particulate material. Each micro screen is designed to treat the 120% of the peak flow values (610 m³/h during summer, 180 m³/h during winter). Micro-screening section is equipped with an emergency bypass channel. The screening material can or, be transported by a screw conveyor to the waste sludge tank and mixed with biological excess sludge or is stored separately, after compacting in dedicated skips before disposal. The total amount of micro screenings production is estimated based on a specific production of 190 L/1000 m³, 1,48 m³/d during summer and 0,18 m³/d during winter before compacting.

6.8 Biological treatment

Biological treatment is based on the metabolism of a wide range of microorganisms and bacteria which eliminate dissolved contamination by assimilating it for the needs of their own growth and reproduction. This leads to an increase of biomass in the form of biological sludge which then is separated from the treated water, dewatered, and discharged. The biological process is based on a suspended growth process activated sludge system. To maintain the culture in suspension, the tanks are mixed. The biological section has three different zones:

- An anaerobic zone stimulating growth of phosphorus accumulating organisms,
- An anoxic zone stimulating anoxic heterotrophic growth converting nitrate and organic matter,
- An aerated zone stimulating aerobic heterotrophic growth for carbon removal and autotrophic growth of nitrifying bacteria converting ammonia to nitrate.

The bioreactor is divided into four parallel treatment lines, increasing plant flexibility, and allowing to cope with flow variations and allow continued operation while taking out one



or two lines for maintenance. The design peak inflow to each treatment line (including backflow) is 55 m³/h and 166 m³/h for winter and summer, respectively. The total estimated hourly peak influent flow during winter is 220 m³/h and during summer 664 m³/h. The average daily inflow is 7.890 m³/d during summer and 565 m³/d during winter.

The four parallel lines have a common inlet channel which also acts as a flow distribution chamber which distributes the flow equally to the three biological lines. The overall activated sludge reactor volume is 2.940 m³. Bioreactors are dimensioned considering storage of pre-treated water up to a maximum water level 0,9 m higher than nominal operation providing an equalization volume of 529,2 m³ which is 18% of the design volume. Separation of sludge and treated water is performed by membranes. This allows for operation using a higher activated sludge concentration then based on gravitational settling.

From the micro-screens, pre-treated water flows to a distribution chamber which distributes the flow equally to the four biological lines. This can be equal distribution or isolating one (or more) line(s) if needed. The biological treatment can be by-passed by means of a weir to protect it from high salinity due to possible seawater intrusion. Measurement of the incoming flow rate is performed in a dedicated pit and in the common inlet pit by electromagnetic flow-measurement and ultrasonic level meter respectively.

6.9 Anaerobic phase

Biological phosphate removal is based on the principle of accumulating phosphorus in biomass and then removing this biomass via the sludge waste. Phosphate-accumulating bacteria (poly-P bacteria or PAO's) require a cyclic growth in an alternating anaerobic and aerobic sequence. First the biomass takes up readily biodegradable organic substrate under anaerobic conditions. The organic matter is stored cell internal in the form of poly-B-hydroxyalcanoates (PHA). The metabolic energy required for this process is obtained from decomposition of intracellular polyphosphates resulting in release of phosphate to the water phase. In a subsequent aerobic and/or anoxic phase, this process is reversed. Under anoxic and aerobic conditions, the bacteria can oxidize PHA using oxygen as well as nitrate. The metabolic energy from this process is utilized for cellular growth and accumulation of polyphosphate. The bacteria thereby taking take up slightly more (excess) phosphate from the water then originally released, due to the growth process. Phosphate is removed from the activated sludge system by removing aerobic (or anoxic) sludge containing stored polyphosphate from the system. The described growth cycle is obtained by feeding wastewater in an anaerobic zone and mixing this with anoxic and/or aerobic activated sludge using sludge recycling pumps. The anaerobic tank is continuously mixed to prevent solids settling and to homogenize untreated water and sludge. The tank is covered and connected to the air treatment system to avoid spreading of odors and gases.

Table 7. Dimensioning of the anaerobic tank.

WWTP Poreč-South - Dimensioning of the anaerobic tank		
Parameter	Unit	Design
Anaerobic zone volume (per line)	m ³	200



Average retention time on inlet flow rate	min	148
Minimum retention time on inlet flow rate	min	79

Biological phosphorus removal can be generally achieved without the addition of physical-chemical dephosphorization. The advantage of not dosing phosphate binding chemicals to the activated sludge system is an improved activated sludge capacity which can instead be used for nitrogen removal. It reduces the costs of operation and reduces the environmental impact. As a backup facility the process is foreseen with ferric chloride dosing downstream the micro-screens.

Table 8. Storing and dosage of reagents for physical/chemical dephosphorization.

WWTP Poreč-South - Storing and dosage of reagents for physical/chemical dephosphorization		
Parameter	Unit	Design
Dosing pump capacity	l/h	10
Total stored volume	m ³	2

6.10 Anoxic tank

Following the anaerobic zone there is an anoxic zone dimensioned as a square mixed tank reactor. The anoxic zone is fed with nitrate from the end of the aerobic zone by recycling pumps placed in a common outlet channel. In the anoxic zone nitrate is reduced to N₂ gas using organic material thereby simultaneously removing nitrogen and COD from the water. The anoxic tank is mechanically mixed to homogenize the sludge-water suspension and prevent settling of sludge particles. The heterotrophic bacteria capable of anoxic conversion use readily available soluble organics from the wastewater for growth. Based on the raw wastewater composition there is no need for additional dosage of COD for denitrification. Biologically removal of nitrogen considerably reduces the oxygen requirement for COD removal and therefore reduces operational costs of wastewater treatment. The anoxic recirculation rate is 270 % relative to the average daily inflow of raw wastewater measured at the inlet. There are four main anoxic recycle pumps and two stand-by units.

Table 9. Main data for anoxic tank dimensioning.

WWTP Poreč-South - Main data for anoxic tank dimensioning		
Parameter	Unit	Design
Anoxic zone volume per line	m ³	175
Average retention time on inlet flow rate	min	129
Minimum retention time on inlet flow rate	min	69



Table 10. Denitrification mass balances and fluxes.

WWTP Poreč-South - Denitrification mass balances and fluxes		
Parameter	Unit	Design
Target value of total nitrogen at outlet	mg N/L	15
NO ₃ to be nitrified in N ₂	kgN-NO ₃ /d	239,3
Actual flux of denitrified NO ₃ in anoxic zone	kgN-NO ₃ /d	237,8
Denitrification kinetics in anoxic zone	gN-NO ₃ /kg VSS/h	3,53

6.11 Aerobic tank

The anoxic zone is followed by an aerated zone. Settled sludge from the membrane compartments is recycled back to the aerobic zone. Oxygen is supplied allowing the aerobic nitrification process and heterotrophic growth thereby eliminating biodegradable organic materials and converting ammonium to nitrite and nitrate. The oxygen supply can be controlled or shut off however, denitrification in the aerated zone is not foreseen as a standard operation. The aeration rate and its sequencing are based on dissolved oxygen measurements by submerged online sensors. Each tank has its own sensor. The aerobic tanks are dimensioned to accommodate the slowest growing organisms being nitrification. Therefore, a minimum aerobic sludge residence time is maintained dependent on the water temperature. The annual average SRT is 17 days. Mixed liquor from the four parallel aerated tanks flows to a common outlet channel and pumped to the membrane sections by three pumps (two for regular operation and one stand-by unit). From the common outlet channel part of the aerobic mixed liquor is recirculated to the anoxic tanks by dedicated pumps. In the common outlet channel pH, TSS, ammonium and nitrate are measured with on-line sensors.

Table 11. Dimensioning of the aeration tank.

WWTP Poreč-South - Dimensioning of the aeration tank		
Parameter	Unit	Design
Aeration basin volume per line	m ³	360
Average retention time on inlet flow rate	min	266
Minimum retention time on inlet flow rate	min	142

6.12 Aeration

Aeration can be performed using different control strategies. The main operation is through Suez patented Greenbass™ technology which controls aeration start-up and shut down thereby regulating the air flow input for the entire reactor. The oxygen supply can also be controlled based on control tables and based on an oxygen setpoint. Aeration is performed by using fine bubble diffusers. Oxygen is supplied according to measured nitrate and/or dissolved oxygen concentrations in defined time intervals. While the dynamics and the energy consumption of the different oxygen control strategies can differ, the yearly average effluent quality for all strategies will meet the projected effluent quality standards. Air is supplied by two sound insulated roots blowers, with an additional stand-by unit per



line. Each roots blower is equipped with a frequency converter and its capacity is equal to 740 Nm³/h. Each diffuser has a maximum allowed airflow peak of about 7 to 10 Nm³/h. The average diffusers installation depth is 5,25 m.

The theoretical oxygen demand for the removal of carbon and nitrogen is related to the following processes:

- Carbon oxidation for biomass synthesis (cell growth),
- Carbon oxidation for cell maintenance (endogenous respiration),
- Oxidation of ammonium to nitrite/nitrate in the nitrification process.

The total air supply is the amount of air (m³/h) required to blow into the water in the form of fine bubbles allowing a gas/liquid oxygen transfer (kgO₂/h) of at least the amount of the theoretical oxygen demand. The design of the aeration and oxygen consumption is based on the following assertions:

Table 12. Oxygen demand and installed capacity.

WWTP Poreč-South - Oxygen demand and installed capacity		
Parameter	Unit	Design
Daily O ₂ demand for cell growth	kg O ₂ /day	1825,5
Daily O ₂ demand for endogenous respiration	kg O ₂ /day	1491,8
Daily O ₂ demand for nitrogen pollution	kg O ₂ /day	1489
Reclaimed quantity during denitrification	kg O ₂ /day	-680
Reclaimed quantity in membrane part	kg O ₂ /day	-125,9
Actual daily O ₂ demand	kg O ₂ /day	4000,4
Theoretical peak coefficient for C and N	-	1,2
Set peak O ₂ value	kg O ₂ /hour	194,3
Installed peak O ₂ value	kg O ₂ /hour	200

Table 13. Diffusers main characteristics.

WWTP Poreč-South - Diffusers main characteristics		
Parameter	Unit	Design
Diffuser performance	%	27,6
Oxygenation capacity	kg/Nm ³	0,3
Transmission coefficient	-	0,412
Oxygenation capacity in actual conditions	kg/Nm ³	0,12
Theoretical air volume to be entered at full useful load per line	Nm ³ /h	1466
Installed blower capacity per biological line	Nm ³ /h	1480
Total installed blower capacity	Nm ³ /h	5920
Blower differential pressure	mbar	580-690
Total installed surface of diffusion	m ²	49,6



6.13 Membrane filtering

Separation of solids and liquid is obtained using a membrane bioreactor (MBR). This comes instead of typical gravitational settling in a clarifier. Membranes form a partly permeable barrier allowing passing of treated water. The permeability threshold is equal to 0,04 μm . Particles greater than membrane openings (suspended solids, bacteria, and the majority of virus) are retained in the treatment plant. The overall effluent quality of a MBR therefore is usually better. The MBR section can be followed by a tertiary treatment, for example nanofiltration, reverse osmosis (RO), chlorination and/or UV treatment. This makes it possible to reuse the effluent for different purposes. The applied membrane type is hollow fiber. Water flows from the outside to the inside caused by low pressure inside the fibers which is continuously maintained by extraction pumps. The extracted filtrate is stored in an effluent storage tank. To prevent clogging of the membranes the fibers are scrubbed with air bubbles by sequential aeration. Each MBR line has a maximum air flow capacity of 972 Nm³/h. Further cleaning is done by time interval backwashing and incidental chemical cleaning. Solid-liquid separation is performed by three independent lines of membranes to provide the required operational flexibility. Each treatment line is equipped with three cassettes: one of them equipped with 48 filtering modules and the other two with 32 modules. From the MBR the sludge fraction is recycled to the aerobic tanks with a recycle rate equal to 500 % of the peak influent flow.

Table 14. Main characteristics of membranes filtration Units.

WWTP Poreč-South - Main characteristics of membranes filtration Units		
Parameter	Unit	Design
Number of filter lines	u	3
Number of cassettes per line	u	3
Number of modules per cassette	u	32-48
Total number of modules	u	336
Area of one module	m ²	34,37
Total filtration area	m ²	11548
Filtration area per line	m ²	3849

Table 15. Main dimensioning data of the membrane section.

WWTP Poreč-South - Main dimensioning data of the membrane section		
Parameter	Unit	Design
TSS concentration (equalization)	g/l	10
TSS concentration (equalization) yearly range	g/L	10 - 15
TSS concentration in bioreactor aerated zones	g/l	8
TSS concentration in bioreactor aerated zones yearly range	g/L	8 - 12
Actual load in mass	kg BOD ₅ /kg TSS/d	0,16
Actual volumetric load	kg BOD ₅ /m ³ /d	1,26
Basin volume	m ³ /line	75



Table 16. Design flow values at plant inlet for MBR dimensioning (design conditions).

WWTP Poreč-South - Design flow values at plant inlet for MBR dimensioning (design conditions)		
Parameter	Unit	Design
4 hours/day	m ³ /h	610
1 day/week	m ³ /h	341
1 week/month	m ³ /h	325
1 month/year	m ³ /h	325
Annual average	m ³ /h	325

Table 17. Flow values at plant inlet in case of one working MBR line.

WWTP Poreč-South - Flow values at plant inlet in case of one working MBR line		
Parameter	Unit	One line
4 hours/day	m ³ /h	400
1 day/week	m ³ /h	341

Excess sludge is collected from a pit in the bottom of the MBR and conveyed to a sludge storage tank feeding the dewatering centrifuges. Excess sludge transfer is performed by submersible pumps (2 units on duty and 1 stand-by unit).

Table 18. Main design parameters of MBR bioreactor.

WWTP Poreč-South - Main design parameters of MBR bioreactor		
Parameter	Unit	Design
Number of Ultrabox reactors	Units	3
Ultrabox useful volume	m ³ /Ultrabox	75
TOTAL Ultrabox useful volume	m ³	225
TOTAL biological lines and Ultrabox	m ³	3165

Table 19. Main operational characteristics of MBR bioreactor for nutrient removal.

WWTP Poreč-South - Main operational characteristics of MBR bioreactor for nutrient removal		
Parameter	Unit	Design
Volumetric load	kg BOD5/m ³ /day	1,26
Load in mass	kg BOD5/kg VSS/day	0,247
TSS concentration in aeration zone	g TSS/l	8
TSS concentration in Ultrabox	g TSS/l	10
Minimal total average sludge age (*)	day	17

(*) SRT calculated excluding the anaerobic zone



6.14 Storage and disinfection of treated water for technical purposes

Treated water is conveyed from membranes section to storage tanks, where it undergoes a disinfection process in view of its reuse. Water for external reuse and trucks filling is stored in a 1.950 m³ tank.

6.15 Excess sludge

Solids captured by the raw wastewater pretreatment micro-screens and excess sludge from the activated sludge process are collected in the sludge storage tank. Sludge from the pretreatment is transported with a screw conveyor. Excess sludge is pumped from the MBR sludge pit using two pumps with one stand-by unit. The sludge tank is mixed for homogenization and to retain the sludge in suspension. The suspended sludge is dewatered using centrifuges. An on-line solids (TSS) measurement is placed in the sludge storage tank used to control the sludge loading of the centrifuges.

Table 20. Sludge dewatering dimensioning and loads.

WWTP Poreč-South - Sludge dewatering dimensioning and loads		
Parameter	Unit	Design
Weekly excess sludge production	kg DS/week	17122
Sludge mass over 6 days	kg DS/day	2854
Density at exit from Ultrafor	g DS/l	10
Total volume excess sludge tank	m ³	150
Biological sludge production (BB)	kg TSS/day	2446
Organic fraction VSS/TSS in biological sludge	%	60

6.16 Dewatering

Dewatering of excess sludge is applied to reduce the storage volume and transportation costs. The sludge is designed to achieve 23% dryness after dewatering. The dewatered sludge is further dried/processed by solar drying or composting. The applied technology for dewatering is high performance centrifuging ($\leq 0,8$ kWh/m³ sludge including a polymer dosage). By applying a centrifugal force, particles in suspension separate from the water phase forming a sediment (dewatered sludge) and centrate (separated liquid). To enhance the dewatering properties of excess sludge, upstream of the centrifuge polymers are added to stimulate flocculation. Polymer dosing (≤ 8 kgAM/tDS) is proportional to the sludge flow, measured at the centrifuge inflow. Centrifuges are operated 6 days a week, 10 hours a day. Excess sludge from the storage tank is transported to the dewatering unit with 3 pumps (2 on duty and 1 stand-by unit) each pump with a capacity of 16 m³/h.



Table 21. Sludge characteristics and operational parameters.

WWTP Poreč-South - Sludge characteristics and operational parameters		
Parameter	Unit	Design
Permitted flow mass per centrifuge	kg DS/h	160
Permitted hydraulic flow per centrifuge	m ³ /h	16
Number of centrifuges	pc	2
Permitted flow mass for dewatering plant	kg DS/h	320
Permitted hydraulic flow for dewatering plant	m ³ /h	32
Applied hydraulic flow for dewatering plant	m ³ /h	28,5 (@ 10 g/l)
Expected dryness at exit from dewatering Unit 6	%	23
Average dewatered sludge quantity at exit from centrifuge for 60 hours of operation weekly	m ³ /h	1,12

Table 22. Sludge storage dimensioning.

WWTP Poreč-South - Sludge storage dimensioning		
Parameter	Unit	Design
Dewatered sludge	kg/weekly	70730
Apparent sludge volume	kg/m ³	1.000/1.100
Weekly sludge production	m ³ /week	67
Total storage autonomy	weeks	1

6.17 Effluent quality requirement

The treated effluent is reused and/or discharged in the Adriatic Sea by a submerged discharge pipe and effluent diffuser. Given the sensitivity of the recipient, the effluent limits are in accordance with Annex IIA, Directive of the European Council 91/271/EEC concerning urban wastewater purification and the amendment 98/15/EEC for WWTP's of a capacity ranging 10.000 to 100.000 person equivalents (PE) and Croatian regulation (OG 80/13). These laws set the requirements for discharge of treated urban wastewater into sensitive areas which are subject to eutrophication.

Table 23. Limit values considered for water discharge.

WWTP Poreč-South - Limit values considered for water discharge			
Parameter	Limit value	Unit	Maximal allowed measurement
Total Suspended Solids (TSS)		mg/l	5
BOD5 (20°C)		mgO ₂ /l	10
COD (TCOD)		mgO ₂ /l	125
Total Phosphorus (TP)		mgP/l	2
Total Nitrogen (TN)		mgN/l	15
Turbidity		NTU	1
Coliforms		CFU/100 ml	2000
Coliforms of fecal origin		CFU/100 ml	500
Streptococci of fecal origin		CFU/100 ml	200



Escherichia Coli	CFU/100 ml	10
Intestinal enterococci	CFU/100 ml	200
pH 6 - 9	pH	6-9

* Limit value for the total nitrogen is applied when the wastewater temperature at the effluent of the aeration tank is equal or greater than 12°C.

6.18 Drainage collection

An on-site drainage system and pumping station receives all used and drained technical water from all different sources and processes of the WWTP as well as sewage from administration building. On-site drainage is lifted to the inlet of the fine screens and treated along with the raw wastewater coming from the sewerage system. The drainage pumping station has a maximum capacity of 30 m³/h using two pumps (one as an auxiliary unit).



7 Influent flow and quality measurements

7.1 Influent sampling and measurements

Raw sewage wastewater was sampled at all 4 WWTP locations. Therefore continuous 24-hour automated samples were used for a continued period of seven days. Per wastewater location the sampling period is 7 days equals 168 hours resulting in 84 sample vessels to be analyzed. The sampling commenced Friday July 19, 2019 at 8:00 AM and finished one week later. The type of sampler used is Hach AS950 Portable Sampler and WaterSam Ports. Samples are taken every 9-30 minutes (flow proportional) in bottles of volume 550–800 mL which are rotated automatically every 2 hours, for 24 h (total of 12 vessels collected per 24 hours for each sampling location). Every day during 7 days of operation the samplers are emptied, and the samples are taken to the laboratory for analysis (Zagreb Laboratory for Water Technology at the Faculty of Food Technology and Biotechnology). Three samplers were placed outdoors, and at the Vrsar site a sampler was placed indoors. Samplers placed outdoors were thermally insulated and refrigerated.

Table 24. Parameters measured in wastewater.

Parameters determined in the wastewater of the city of Poreč.				
Code	Parameter	2h/24h composite	Filtered / Total	Chemical analysis method
TCOD	Total Chemical Oxygen Demand	2 hour composite	Total sample	ISO 6060-1989
CODMF	Chemical Oxygen Demand in filtrate (1.2 µm)	2 hour composite	Micro filtered	ISO 6060-1989
TN	Total nitrogen	2 hour composite	Total sample	EN ISO 11905-1 decomposition s peroxodisulfate
PO4	Orthophosphate	2 hour composite		DIN EN ISO 6878
NH4	Ammonia	2 hour composite		ISO 7150-1
TSS	Total suspended solids	2 hour composite	Total sample	Filtered, dried, weight
VSS	Volatile suspended solids (organic)	2 hour composite		Total solids minus inorganic fraction
ISS	Inorganic suspended solids	2 hour composite		Filtered, dried, weight, incinerated at 500 C, weight
pH	pH	2 hour composite		
EC	Electrical conductivity	2 hour composite		
BOD	Biological Oxygen demand over 5 days	24 hour composite	Total sample	Test run over 5 days
BODMF	Biological Oxygen demand over 5 days in filtrate (1.2 µm)	24 hour composite	Micro filtered	Test run over 5 days
TP	Total phosphorus	24 hour composite	Total sample	EN ISO 6878
NO3	Nitrate	24 hour composite		ISO 7890-1-2-1986
NO2	Nitrite	24 hour composite		EN ISO 26777



7.2 Influent flow

The average influent flow is measured for the 4 plants according to the tables below.

Table 25. Winter – Average Influent Flow per WWTP.

Winter - Average flow per day per WWTP	
	Average of Flow Average (m ³ /d)
Lanterna	238,9
Vrsar	393,5
Poreč-North	2106,4
Poreč-South	582,9

Table 26. Summer – Average Influent Flow per WWTP.

Summer - Average flow per day per WWTP	
	Average of Flow Average (m ³ /d)
Lanterna	2736,6
Vrsar	1914,6
Poreč-North	4429,6
Poreč-South	5849,4

7.3 Time average versus flow-proportional concentration

In this study model calculations are based on 24-hour dynamic influent flow and concentration dynamics and static daily average flow and concentrations. Two different methods are used to determine these flows and concentrations.

The hourly concentration is measured using an automatic flow-proportional sampler, with a sampling rotor containing 12 sampling vessels. An empty vessel is rotated in to place every 2-hours over a 24-hour period. Sample volumes are collected using a flow proportional sampling method. Therefore, the sampling pump is controlled based on measurement of the influent flow. The influent flow measurement gives a pulse to a sampling pump every time a certain influent volume is measured. The sampling frequency thereby increases proportionally with the measured influent flow. The sample volume is determined by a preset running time of the sampling pump each time it is activated by the flow meter. The combination of sampling pump operation frequency and running time is set-up in a way the maximum collected volume over a 2-hour period never exceeds the volume of the sample vessel. Thereby the sampler also should take a minimum amount of sample every 2-hours to satisfy the volume requirements for the laboratory, even when the influent flow is at its minimum.

With a daily flow variation, this 24-hour sampling method results in a sample rotor with each of the 12 vessels filled at variable volume, dependent on influent flow which was measured during the 2-hour sample interval. The content of each vessel is a mixed composition of influent samples (pulses) in which high flow conditions are more frequently sampled. Laboratory analysis of each mixed 2-hour sample represents the



average flow proportional concentration for that 2-hour period. Based on 12 samples a 24-hour dynamic concentration profile is obtained which can be used for modelling purposes.

For static modeling, the 2-hour interval concentration measurements are used to calculate a daily average flow proportional concentration. This is done for each measured influent parameter. By multiplying the 2-hour composite concentration with the measured influent volume over the same 2-hour period, the 2-hour interval influent load is obtained. The daily influent load over 24-hours is obtained by taking the sum of the 12 calculated 2-hour loads. The daily average flow weighed concentration is obtained by dividing the daily load by the daily influent flow. Only flow weighed concentration data are used for static design and model calculations.

An incorrect method of applying concentration measurements in modeling is calculating the average concentration directly from concentration measurements without weighing. Thus, not taking in consideration the flow conditions under which concentrations are measured. When using these data for design calculations, the plant loading will be underestimated when more rain events are measured and overestimated when more dry weather events are measured. At a rain event, the concentration is low as result of dilution of influent however, the plant loading is increased due to the increased flow. During dry weather relative concentrated influent may be measured, however the loading effect on the plant is limited due to often lower flow conditions. The following graph shows the flow-weighted influent concentrations for each of the treatment plants in the Poreč area.

7.4 Influent concentration

From the 24-hour influent 2-hour composite measurements for each parameter an average flow proportional influent concentration is calculated. The weighted average influent concentration is used for further design calculations. The summer and winter results are presented in the graphs below.

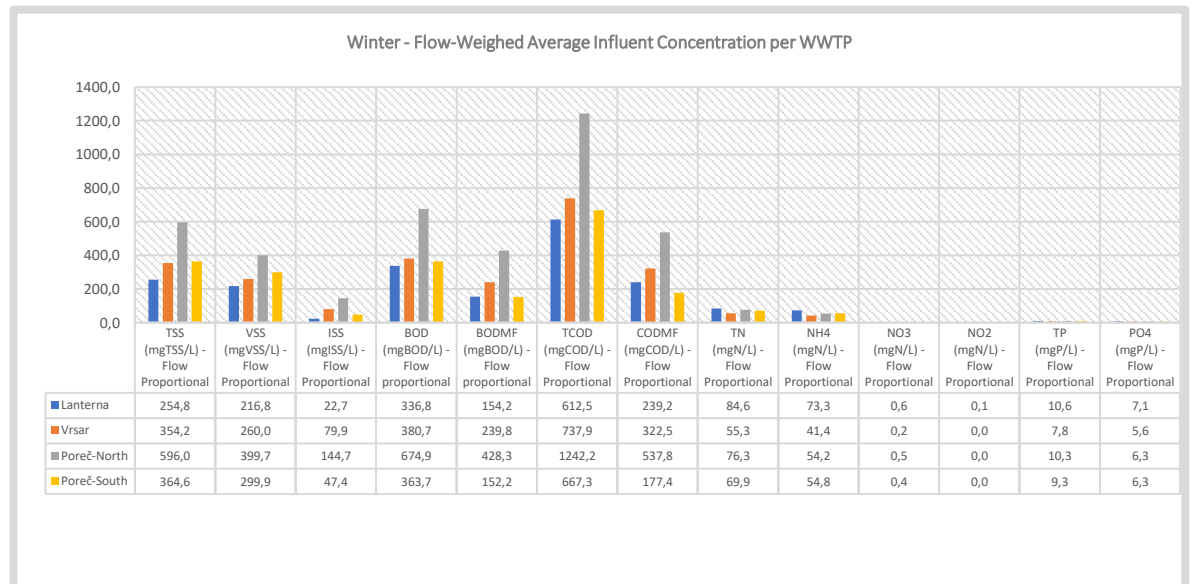

Figure 7. Winter - Flow-Weighed Average Influent Concentration per WWTP.



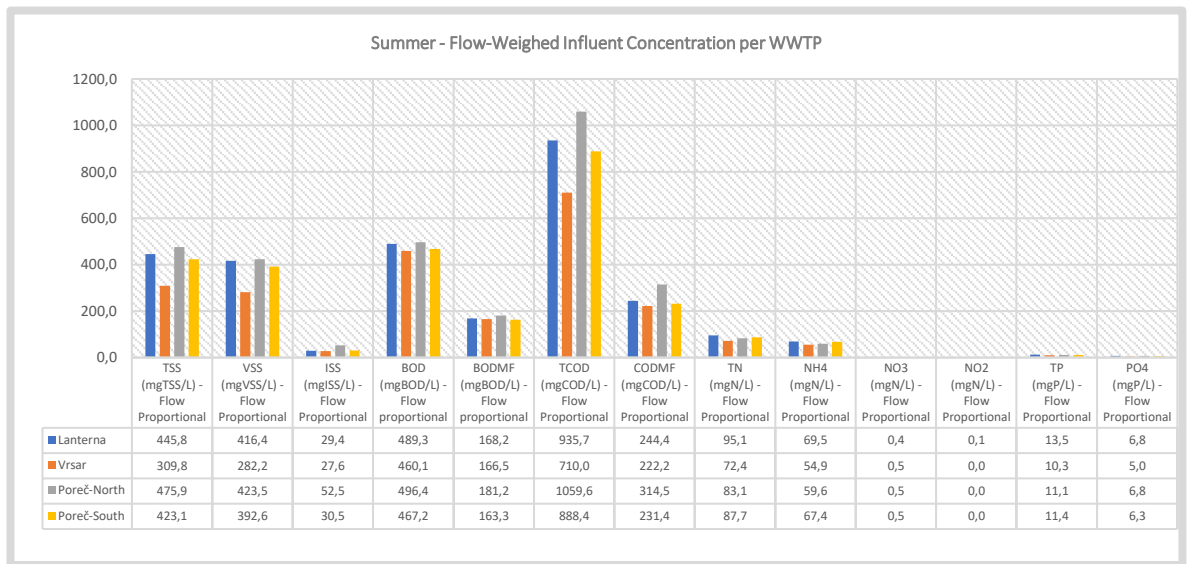

Figure 8. Summer - Flow-Weighed Average Influent Concentration per WWTP.

During the summer, the concentrations of wastewater are slightly higher, most likely due to absence of rain and less water infiltration. TSS and VSS and other particulate fractions seem to increase relative to the other fractions. This could be caused by the shorter sewer residence time due to an increased flow and better mixing. Hydrolysis of particulate matter could be less in the summer due to a decreased time in the sewer system.

7.5 Average influent loads winter and summer period

The graphs below show daily average influent loads based on 7 days 24-hour, 2-hour interval continuous influent measurements measured under winter and summer conditions. The scale of graphs (0-100%) represents the influent fraction each WWTP treats relative to the total Poreč influent load. In the summer, all WWTP have a considerable higher loading. The increased summer loading of WWTP Poreč-North is approximately 200% of WWTP Vrsar it is 500%, and of WWTP Poreč-South and Lanterna the wastewater to be treated increases approximately tenfold by 1000%.

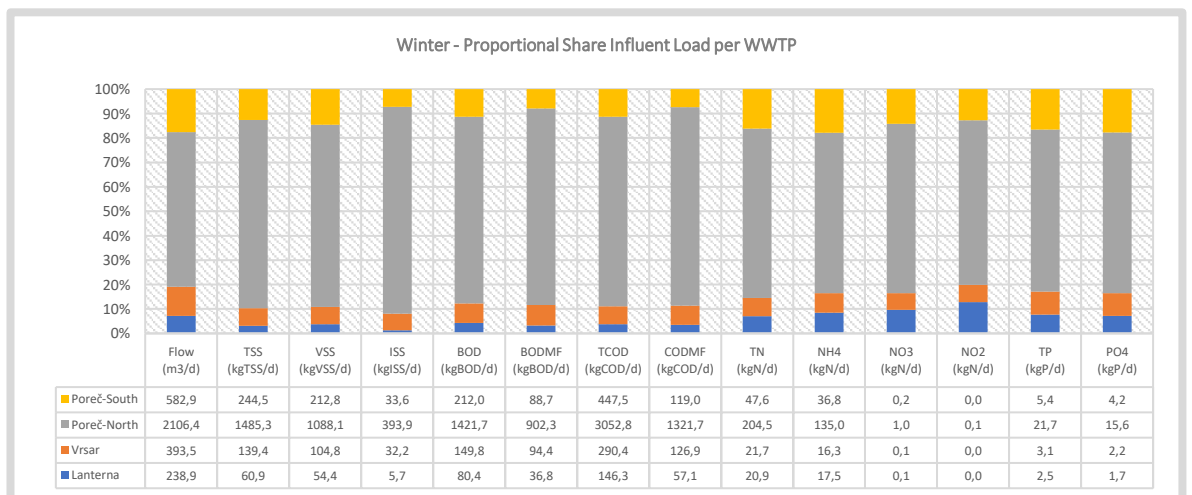

Figure 9. Winter - Proportional Share Influent Load per WWTP.

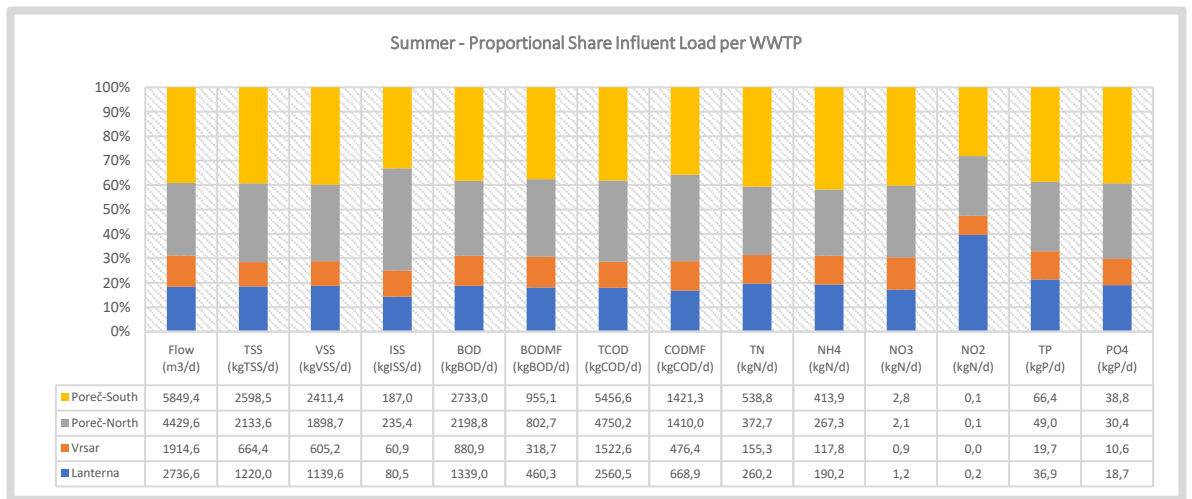

Figure 10. Summer - Proportional Share Influent Load per WWTP.



8 BioWin Influent characterization

8.1 Influent (BOD and COD) Wastewater Fractions

The wastewater fractions tab in BioWin shows the parameters in Table 27. By these parameters, the fractional composition of the influent wastewater is calculated. Note that these fractions are in terms of COD. Even though the overall wastewater strength is entered in terms of BOD, the BioWin model calculates the strength in terms of COD and uses these fractions to place values in the state vector. BOD is calculated from the COD using the methodology presented further on in this chapter. In the BOD and COD influent wastewater fractions tab the following fractional values can be specified (Table 27).

Table 27. BioWin typical influent fractions. Fractions are presented in the text.

WWTP Poreč-South - Winter/Summer Result Influent Specifier - Initial input COD Influent Fractions			
Name	Raw Wastewater Defaults	Winter Calibrated Value	Summer Calibrated Value
Fbs - Readily biodegradable (including Acetate) [gCOD/g of total COD]	0,160	0,228	0,232
Fac - Acetate [gCOD/g of readily biodegradable COD]	0,150	0,233	0,224
Fxsp - Non-colloidal slowly biodegradable [gCOD/g of slowly degradable COD]	0,750	0,892	0,893
Fus - Unbiodegradable soluble [gCOD/g of total COD]	0,050	0,037	0,028
Fup - Unbiodegradable particulate [gCOD/g of total COD]	0,130	0,089	0,105
Fcel - Cellulose fraction of unbiodegradable particulate [gCOD/gCOD]	0,500	0,837	0,593
Fna - Ammonia [gNH ₃ -N/gTKN]	0,660	0,787	0,773
Fnox - Particulate organic nitrogen [gN/g Organic N]	0,500	0,163	0,163
Fnus - Soluble unbiodegradable TKN [gN/gTKN]	0,020	0,010	0,010
FupN - N:COD ratio for unbiodegradable part. COD [gN/gCOD]	0,070	0,070	0,070
Fpo4 - Phosphate [gPO ₄ -P/gTP]	0,500	0,677	0,553
FupP - P:COD ratio for unbiodegradable part. COD [gP/gCOD]	0,022	0,001	0,001
Fsr - Reduced sulfur [H ₂ S] [gS/gS]	0,150	0,150	0,150
FZbh - Ordinary heterotrophic COD fraction [gCOD/g of total COD]	0,020	0,025	0,025
FZbm - Methyloctrophic COD fraction [gCOD/g of total COD]	0,0001	0,0001	0,0001
FZao - Ammonia oxidizing COD fraction [gCOD/g of total COD]	0,0001	0,0001	0,0001
FZno - Nitrite oxidizing COD fraction [gCOD/g of total COD]	0,0001	0,0001	0,0001
FZaao - Anaerobic ammonia oxidizing COD fraction [gCOD/g of total COD]	0,0001	0,0001	0,0001
FZppa - Phosphorus accumulating COD fraction [gCOD/g of total COD]	0,0001	0,0001	0,0001
FZpa - Propionic acetogenic COD fraction [gCOD/g of total COD]	0,0001	0,0001	0,0001
FZam - Acetoclastic methanogenic COD fraction [gCOD/g of total COD]	0,0001	0,0001	0,0001
FZhm - Hydrogenotrophic methanogenic COD fraction [gCOD/g of total COD]	0,0001	0,0001	0,0001
FZso - Sulfur oxidizing COD fraction [gCOD/g of total COD]	0,0001	0,0001	0,0001
FZsrpa - Sulfur reducing propionic acetogenic COD fraction [gCOD/g of total COD]	0,0001	0,0001	0,0001
FZsra - Sulfur reducing acetotrophic COD fraction [gCOD/g of total COD]	0,0001	0,0001	0,0001
FZsrh - Sulfur reducing hydrogenotrophic COD fraction [gCOD/g of total COD]	0,0001	0,0001	0,0001
FZe - Endogenous products COD fraction [gCOD/g of total COD]	0,0000	0,0000	0,0000



Technical note on influent fractions: Setting fractions to zero may result in steady state solution difficulties. If values for biomass fractions are entered (FZ-fractions) it should be remembered that organisms contain nitrogen and phosphorus.

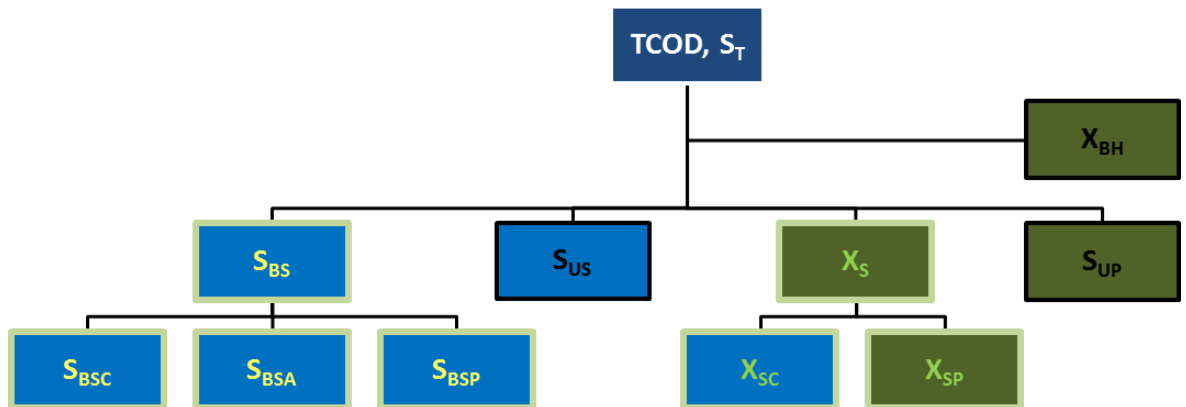

Figure 11. Division of BioWin municipal wastewater total COD (TCOD) into constituent fractions. Blue is soluble (S) and (olive) green particulate or colloidal particulate (X). Green lined boxes are biodegradable and black lined boxes are inert. Yellow text indicates readily biodegradable and green text slowly biodegradable.

Table 28. BioWin summer influent measurements for determining model fractions.

Influent measurements for BioWin Influent Characterization - Summer						
Main influent measurements	Notations	Unit	Lanterna	Vrsar	Porec-North	Porec-South
Flow	Q	m ³ /d	2737	1915	4430	5849
Total COD	TCOD, ST	mgCOD/L	936	710	1060	888
Total Kjeldahl Nitrogen	TKN	mgN/L	95	72	83	87
Total P	TP	mgP/L	13,5	10,3	11,1	11,4
Other influent measurements	Notations	Unit	Lanterna	Vrsar	Porec-North	Porec-South
Nitrate N	NO ₃ -N, SNO ₃	mgN/L	0,5	0,5	0,0	3,6
pH	pH	-	7,3	7,8	7,8	7,8
Alkalinity (CaCO ₃ equivalent)	Alk	mgCaCO ₃ /L	373	450	247	340
Calcium	Ca, Sca	mg/l	80	103	92	100
Magnesium	Mg, SMg	mg/l	15	36	41	19
Dissolved oxygen	DO, (SO ₂)	mgO ₂ /l	0,0	1,2	3,1	0,0
Additional measurements for modeling	Notations	Unit	Lanterna	Vrsar	Porec-North	Porec-South
Effluent filtered COD	CODS_EFF	mgCOD/L	25	16	29	26
Influent filtered COD (including colloidal)	CODGF_INF, CODS_INF	mgCOD/L	306	110	210	147
Influent FF COD (excluding colloidal)	CODMF_INF	mgCOD/L	244	80	186	60
Influent acetate	HAc, VFA, SA	mgCOD/L	48,9	0,0	1,7	0,0
Influent ammonia	NH ₄ -N, SNH ₄	mgN/l	69,5	16,8	19,3	26,2
Influent ortho-phosphate	PO ₄ -P, SPO ₄	mgP/l	6,8	2,2	2,3	3,6
Influent carbonaceous BOD ₅	TCBOD, TBOD, BOD ₅	mgO ₂ /l	489	197	303	223
Influent filtered cBOD ₅	SCBOD, SBOD, BODS	mgO ₂ /l	168	66	129	85
Influent VSS	VSS	mgVSS/L	416	194	272	199
Influent TSS	TSS	mgTSS/L	446	244	317	227
Derived model fractions	Notations	Unit	Lanterna	Vrsar	Porec-North	Porec-South
Fraction unbiodegradable Soluble COD	Fus	-	0,03	0,04	0,02	0,03
Particulate COD non-colloidal	CODp, CODX	mgCOD/l	630	432	666	599
Readily biodegradable COD including VFA	Fbs	-	0,23	0,28	0,27	0,23
Acetate fraction of readily biodegradable COD (SBS)	Fac	-	0,22	0,23	0,22	0,22
fraction ammonia of TKN	Fna	-	0,73	0,76	0,72	0,77
fraction phosphate of TP	Fpo ₄	-	0,50	0,49	0,57	0,55
TCOD/BOD ₅ , total COD over BOD ₅ ratio	TCOD/BOD ₅	-	1,91	1,71	2,13	1,91
CODX/VSS, particulate (non-colloidal) COD/VSS ratio	Fcv	-	1,48	1,46	1,43	1,45
Inorganic suspended solids (ash fraction of TSS)	ISS	mg/l	29	28	58	32

Table 29. BioWin winter influent measurements for determining model fractions.

Influent measurements for BioWin Influent Characterization - Winter						
Main influent measurements	Notations	Unit	Lanterna	Vrsar	Porec-North	Porec-South
Flow	Q	m ³ /d	239	394	2106	583
Total COD	TCOD, ST	mgCOD/L	613	738	1242	667
Total Kjeldahl Nitrogen	TKN	mgN/L	84	55	76	70
Total P	TP	mgP/L	10,6	7,8	10,3	9,3
Other influent measurements	Notations	Unit	Lanterna	Vrsar	Porec-North	Porec-South
Nitrate N	NO ₃ -N, SNO ₃	mgN/L	0,7	0,2	0,5	0,4
pH	pH	-	7,3	7,3	7,3	7,3
Alkalinity (CaCO ₃ equivalent)	Alk	mgCaCO ₃ /L	373	373	373	373
Calcium	Ca, SCa	mg/l	80	80	80	80
Magnesium	Mg, SMg	mg/l	15	15	15	15
Dissolved oxygen	DO, (SO ₂)	mgO ₂ /l	0,0	0,0	0,0	0,0
Additional measurements for modeling	Notations	Unit	Lanterna	Vrsar	Porec-North	Porec-South
Effluent filtered COD	CODS_EFF	mgCOD/L	25	26	27	28
Influent filtered COD (including colloidal)	CODGF_INF, CODS_INF	mgCOD/L	299	403	672	222
Influent FF COD (excluding colloidal)	CODMF_INF	mgCOD/L	239	323	538	177
Influent acetate	HAc, VFA, SA	mgCOD/L	47,8	64,5	107,6	35,5
Influent ammonia	NH ₄ -N, SNH ₄	mgN/l	73,3	41,4	54,2	54,8
Influent ortho-phosphate	PO ₄ -P, SPO ₄	mgP/l	7,1	5,6	6,3	6,3
Influent carbonaceous BOD ₅	TCBOD, TBOD, BOD ₅	mgO ₂ /l	337	381	675	364
Influent filtered cBOD ₅	SCBOD, SBOD, BODS	mgO ₂ /l	193	264	428	137
Influent VSS	VSS	mgVSS/L	217	260	400	300
Influent TSS	TSS	mgTSS/L	255	354	596	365
Derived model fractions	Notations	Unit	Lanterna	Vrsar	Porec-North	Porec-South
Fraction unbiodegradable Soluble COD	Fus	-	0,04	0,03	0,02	0,04
Particulate COD non-colloidal	CODp, CODX	mgCOD/l	314	335	570	446
Readily biodegradable COD including VFA	Fbs	-	0,35	0,40	0,41	0,23
Acetate fraction of readily biodegradable COD (SBS)	Fac	-	0,22	0,22	0,21	0,23
fraction ammonia of TKN	Fna	-	0,87	0,75	0,72	0,79
fraction phosphate of TP	Fpo ₄	-	0,67	0,72	0,61	0,68
TCOD/BOD ₅ , total COD over BOD ₅ ratio	TCOD/BOD ₅	-	1,82	1,98	1,84	1,88
CODX/VSS, particulate (non-colloidal) COD/VSS ratio	Fcv	-	1,44	1,29	1,42	1,47
Inorganic suspended solids (ash fraction of TSS)	ISS	mg/l	38	94	196	65

Note on the table: pH, Ca, Mg, and alkalinity are used for pH and chemical precipitation reactions. Effluent COD_S is for systems with SRT > 3 days equal to the unbiodegradable (inert) soluble COD (Fus, SI). Glass Filtered COD (COD_{GF}) - Glass fiber filter 1,2 microns and typically is 40% of TCOD. Membrane Filtered COD (COD_{MF}) - flocculated and membrane filtered 0,45 microns and thereby COD_{MF}<COD_{GF}. BOD measurements are all including ATU inhibiting nitrification. Volatile fatty acids are often inaccurate assumed acetate.

8.2 Calculating BioWin influent fractions from influent measurements

The influent is divided in its fractions and used in the BioWin model calculations. Therefore, several influent fractions are introduced to facilitate the calculations in the model (Table 27, BW-influent tab). An overview of the fractions is presented below including relation to actual analytical measurements.

The influent unbiodegradable COD (S_{US}) for systems with a SRT > 3 days is based on the effluent measurement of soluble (glass filtered) COD according to:

$$S_{US} = COD_{S,EFF} = COD_{GF,EFF}$$

(Eq. 1)



The fraction unbiodegradable COD is calculated according to:

$$F_{US} = \frac{S_{US}}{TCOD} = \frac{COD_{GF,EFF}}{TCOD_{INF}}$$

(Eq. 2)

Soluble COD is including the colloidal and expressed as COD_S as the sum of all soluble model fractions. It can be measured from glass filtered COD according to:

$$COD_S = S_{BSA} + S_{BSP} + S_{BSC} + X_{SC} + S_{US} = COD_{GF,INF}$$

(Eq. 3)

Particulate (non-colloidal) COD (COD_p or COD_x) is the sum of particulate (non-colloidal) COD, particulate unbiodegradable COD and active biomass in the influent (X_{BH} is often assumed zero) given by:

$$COD_x = X_{SP} + S_{UP} + X_{BH} \approx X_{SP} + S_{UP}$$

(Eq. 4)

COD_x is calculated by subtracting the total COD and the soluble COD (COD_S) which is calculated based on the glass filtered COD according to:

$$COD_x = TCOD - COD_S = TCOD_{INF} - COD_{GF,INF}$$

(Eq. 5)

Soluble COD excluding the colloidal is expressed as COD_{MF} and measured from membrane filtering the COD according to:

$$COD_{MF} = S_{BSA} + S_{BSP} + S_{BSC} + S_{US} = COD_{MF,INF}$$

(Eq. 6)



The total soluble readily biodegradable COD (the total of acetate, propionate and complex soluble COD but without slowly colloidal COD) is calculated from the measured micro filtered fraction COD_{MF} according to:

$$S_{BS} = S_{BSA} + S_{BSP} + S_{BSC} = COD_{MF} - S_{US} = COD_{MF,INF} - COD_{GF,EFF}$$

(Eq. 7)

The fraction of soluble readily biodegradable COD is given by:

$$F_{BS} = \frac{S_{BS}}{TCOD} = \frac{(S_{BSA} + S_{BSP} + S_{BSC})}{TCOD} = \frac{COD_{MF,INF} - COD_{GF,EFF}}{TCOD_{INF}}$$

(Eq. 8)

Influent acetate (+ propionate) is direct measured as VFA:

$$S_{BSA} + S_{BSP} = VFA_{INF}$$

(Eq. 9)

The fraction of readily biodegradable COD which is acetate is given by:

$$F_{AC} = \frac{S_{BSA}}{S_{BS}} = \frac{S_{BSA}}{(S_{BSA} + S_{BSP} + S_{BSC})} = \frac{VFA_{INF}}{COD_{MF,INF} - COD_{GF,EFF}}$$

(Eq. 10)

From the difference between the glass and membrane filtered COD, the colloidal fraction can be calculated according to:

$$X_{SC} = COD_S - COD_{MF} = COD_{GF,INF} - COD_{MF,INF}$$

(Eq. 11)

The last soluble parameter to be calculated is the complex soluble COD S_{BSC} calculated from the measurements according to:



$$S_{BSC} = COD_{MF} - S_{BSA} - S_{BSP} - S_{US} = COD_{MF,INF} - VFA_{INF} - COD_{GF,EFF}$$

(Eq. 12)

The total soluble (readily and slow colloidal) biodegradable COD (S_S) is the total of acetate, propionate, complex soluble COD and colloidal COD (influent methanol is assumed zero) given by:

$$S_S = S_{BSA} + S_{BSP} + S_{BSC} + X_{SC}$$

(Eq. 13)

And calculated according to:

$$S_S = COD_S - S_{US} = COD_{GF,INF} - COD_{GF,EFF}$$

(Eq. 14)

In Figure 12 the division of municipal wastewater Biodegradable COD (S_S) into constituent fractions. BioWin notation of S_S should not be confused with IAWQ notation where S_S equals BioWin S_{BS} .

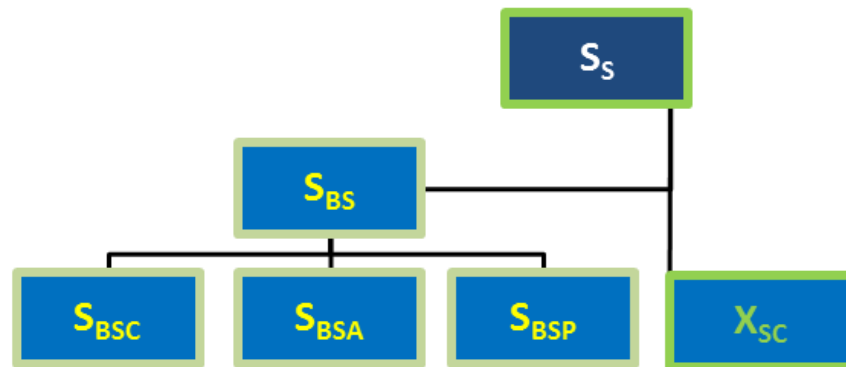

Figure 12. BioWin municipal wastewater soluble biodegradable COD (S_S). The fraction is measured by glass filtering and includes all soluble and colloidal material. Blue fractions are soluble and (olive) green fractions (colloidal) particulate.

The last two influent fraction that need to be calculated are related to the solids; particulate biodegradable COD and unbiodegradable COD according to (Eq. 4):

$$COD_X = X_{SP} + S_{UP} + X_{BH} \approx X_{SP} + S_{UP}$$



These fractions are estimated from the BOD measurements in the influent as explained in the following sections of this chapter.

The BioWin influent tab the fraction of slowly biodegradable influent COD which is particulate is given by:

$$F_{XPS} = \frac{X_{SP}}{X_{SC} + X_{SP}}$$

(Eq. 15)

VSS is often calculated from ISS (Ash) measurement according to:

$$VSS = TSS - ISS$$

(Eq. 16)

The influent ratio of particulate (non-colloidal) COD to VSS is given by:

$$F_{CV} = \frac{COD_X}{VSS} = \frac{TCOD - COD_S}{VSS} = \frac{TCOD_{INF} - COD_{GF,INF}}{TSS - ISS}$$

(Eq. 17)

Ammonia is given by:

$$NH_3 = F_{NA} \times TKN$$

(Eq. 18)

Soluble unbiodegradable organic nitrogen is given by:

$$N_{US} = F_{NUS} \times TKN$$

(Eq. 19)

Nitrogen from organisms present in the influent is calculated by the sum of the products of the various organism concentrations and their respective nitrogen fractions, i.e.:



$$Organisms, N = \sum Zb_x - f_{N,Zbx}$$

(Eq. 20)

Unbiodegradable particulate nitrogen is given by:

$$X_{IN} = F_{UP,N} \times F_{UP} \times TCOD$$

(Eq. 21)

The remaining organic nitrogen is broken into particulate and soluble components. Particulate biodegradable organic nitrogen is given by:

$$X_{ON} = (TKN - NH_3 - N_{US} - X_{IN} - Organisms, N) \times F_{NOX}$$

(Eq. 22)

Soluble biodegradable organic nitrogen is given by:

$$N_{OS} = (TKN - NH_3 - N_{US} - X_{IN} - Organisms, N) \times (1 - F_{NOX})$$

(Eq. 23)

Similarly, an explanation of the fractionation of influent phosphorus is as follows. Soluble orthophosphate is given by:

$$PO_4 = F_{PO_4} \times TP$$

(Eq. 24)

Phosphorus from organisms present in the influent is calculated by the sum of the products of the various organism concentrations and their respective phosphorus fractions, i.e.:

$$Organisms, P = \sum Zb_x - f_{P,Zbx}$$

(Eq. 25)

Unbiodegradable particulate phosphorus is given by:



$$X_{IN} = F_{UP,P} \times F_{UP} \times TCOD$$

(Eq. 26)

The remaining particulate biodegradable organic phosphorus is given by:

$$X_{OP} = TP - PO_4 - X_{IP} - Organisms, P$$

(Eq. 27)



9 Model design reconstruction 2019 measured influent load.

9.1 BioWin model setup

Based on the design flow diagrams an initial modelling setup is developed for summer and winter conditions. The model is fully based on design parameters. The applied influent load and composition is according to actual measurements in the winter and summer of 2019. The design is based on the 2045 loading prognosis. The here performed static simulations are indicative for the operation under current loading conditions. Some uncertainty exists concerning estimated design values to produce grit, screening, and waste sludge. These values need to be established in practice. Modelling was done based on all default BioWin parameter setting except for the anoxic reduction factor for heterotrophs which was set to 0,8, being the standard value for fully denitrifying AS systems. When operational data is available parameter estimations may be adjusted.

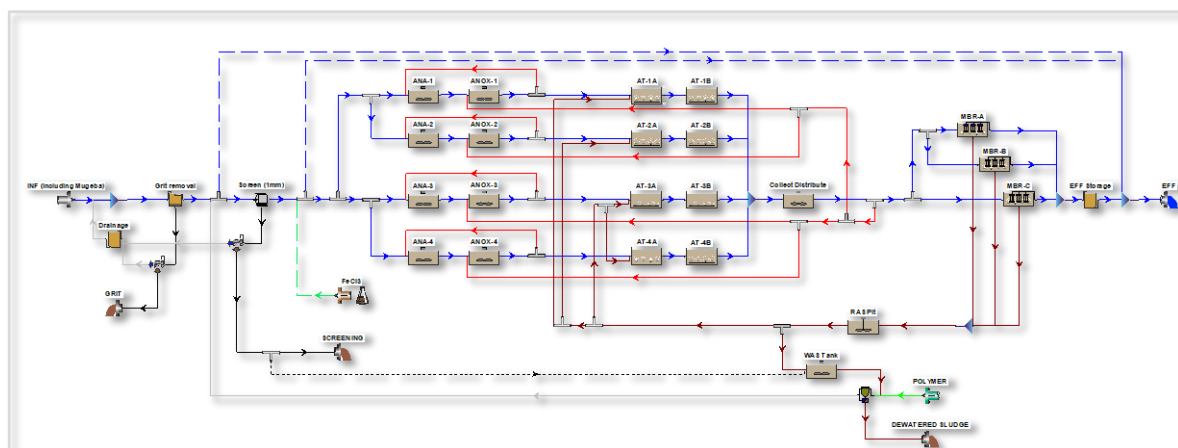

Figure 13. BioWin model initial summer operation setup. Parallel activated sludge lines similarly operated are available for treatment of wastewater. Dashed lines are commonly not applied. A larger picture is found in the appendix. The model is simulated at 20 degrees Celsius.



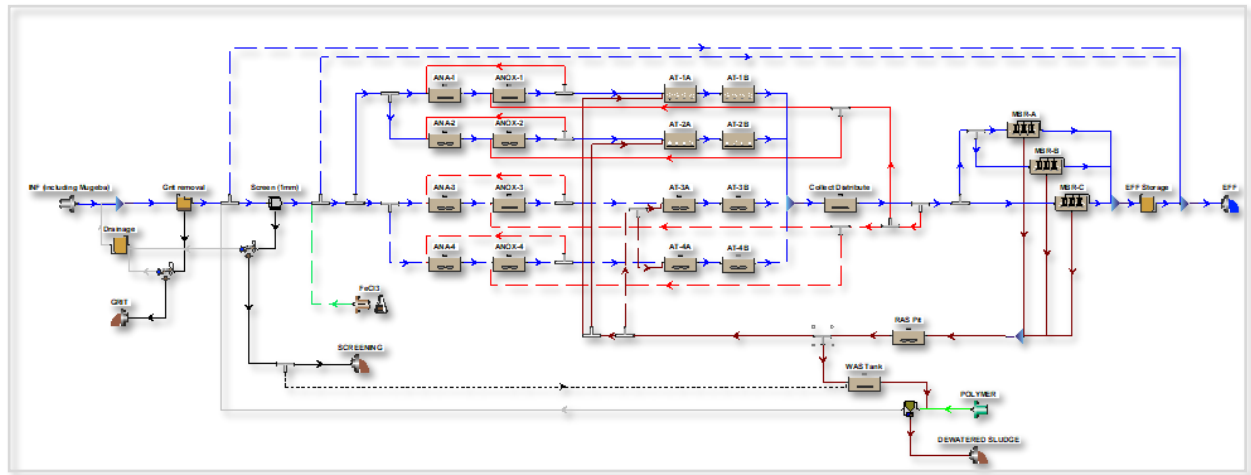

Figure 14. BioWin model initial winter operation setup. One activated sludge line is operated for treatment of wastewater. Dashed lines are commonly not applied. A larger picture is found in the appendix. The model is simulated at 12 degrees Celsius.

9.2 Model considerations

The model input is raw wastewater measured during high and low season (2019). This influent load is without internal dirty water flows originating from the WWTP pretreatment and dewatering. To correctly estimate the internal dirty water loading, the pretreatment units and dewatering are modelled.

It is chosen to model all parallel lanes, because the number of lanes in operation is determined by the actual wastewater flow during high and low season. This variable can be part of the scenario study and therefore is included in the model. The model approach is to vary the flow distribution (splitters) to the different lanes for different operational scenarios. This is the most realistic approach and moreover, gives the opportunity to simulate possible effects on the effluent quality when lanes are taken in or out of operation.

Collected effluent is buffered in a storage tank for possible reuse. This tank is modelled to predict equalizing effects on the effluent concentration during 24-hour dynamic simulations. This feature is important for sea water loading calculations of possible contaminants over time.

Analytical measurements are without grease and without sand. Fine screening at 6 mm is therefore not included in the model because it has no effect on the measured plant loading. The same applies to grease and grit removal. The grit unit is included for explanatory reasons.

The effects of fine screening sometimes can be neglected. However, for MBR systems it could be the case a considerable load of organic fibers is removed lowering the loading of nonbiodegradable particulate substance and consequently affecting the sludge age and sludge production of the WWTP. It should be established in practice, based on measurement data of screening materials whether this is justified and tested in the model by a sensitivity calculation to determine the effect on the effluent calculations.



Volumes for return activated sludge and waste sludge storage (RAS pit and WAS storage) are included to simulate partial anaerobic degradation which could become relevant when the temperature is high or when the sludge storage is longer than 24-hour in average.

A chemical dosage is added to the model to indicate the possibility. During normal summer operation this is not applied. During the winter, a small chemical dose may be necessary.

The emergency bypasses are modelled but not applied. They are included for the scenario study. It needs to be determined from model evaluation, which operational setting are included in the scenario calculations.

The dewatered sludge production is a combination of waste activated sludge and screening. For SRT calculation only the waste activated sludge should be taken in consideration from the measurement data.

9.3 Model results

A full model description is included in the appendix. Here some key performance indicators of static simulations are presented in tables. The method of operation may be different in practice and the measured operational data may deviate from these model results. Not all key operational indicators are calculated correctly due to estimations made where accurate data is missing from the design reports.

Table 30. Winter and Summer SRT calculations.

Name	Winter	Summer	Calculation method
SRT Classic (d)	32,33	7,37	ANOX + AT + Collect Distribute + MBR
SRT Aerobic AS Total	22,98	5,32	AT + MBR
SRT Biology	32,33	7,37	ANA + ANOX + AT + CD + MBR
SRT Actual	44,07	9,58	ANA + ANOX + AT + CD + MBR + RAS pit + WAS storage
SRT Aerobic ex MBR	14,57	4,12	AT

Table 31. Summer influent data average flow/time weighted

Element name	Summer	Winter
Flow	5849,4	582,9
COD - Total mgCOD/L	888,40	667,30
N - Total Kjeldahl Nitrogen mgN/L	87,20	69,60
P - Total P mgP/L	11,40	9,30
S - Total S mgS/L	10,00	10,00



N - Nitrate mgN/L	0,50	0,40
pH	7,30	7,30
Alkalinity mmol/L	7,46	7,46
ISS Total mgISS/L	32,00	64,70
Metal soluble - Calcium mg/L	80,00	80,00
Metal soluble - Magnesium mg/L	15,00	15,00
Gas - Dissolved oxygen mg/L	0	0

Table 32. Modelled design volumes. During winter some lanes may be closed.

Element name	Volume [m3]	Area [m2]	Depth [m]	# of diffusers
ANA-1	200,0000	36,3636	5,500	Un-aerated
ANOX-1	175,0000	31,8182	5,500	Un-aerated
AT-1A	180,0000	32,7273	5,500	163
ANA-3	200,0000	36,3636	5,500	Un-aerated
ANOX-3	175,0000	31,8182	5,500	Un-aerated
AT-3A	180,0000	32,7273	5,500	163
ANA-4	200,0000	36,3636	5,500	Un-aerated
ANOX-4	175,0000	31,8182	5,500	Un-aerated
AT-4A	180,0000	32,7273	5,500	163
Collect Distribute	198,0000	36,0000	5,500	Un-aerated
RAS Pit	81,8230	40,9115	2,000	Un-aerated
WAS Tank	150,0000	2,8302	53,000	Un-aerated
ANA-2	200,0000	36,3636	5,500	Un-aerated
ANOX-2	175,0000	31,8182	5,500	Un-aerated
AT-2A	180,0000	32,7273	5,500	163
AT-1B	180,0000	32,7273	5,500	163
AT-2B	180,0000	32,7273	5,500	163
AT-3B	180,0000	32,7273	5,500	163
AT-4B	180,0000	32,7273	5,500	163

Table 33. Operating data Average (flow/time weighted as required)

Element name	Split method	Average Split specification
ANA-R1	Flow paced	25,00 %
ANA-R3	Flow paced	25,00 %
ANA-R4	Flow paced	25,00 %
MBR Distribute 1	Fraction	0,67
AS Emergency Bypass	Bypass	7890



INF Distributer 1	Fraction	0,50
INF Distributer 3	Fraction	0,50
Screen Emergency Bypass	Bypass	14640
ANOX-R1	Flow paced	270,00 %
ANOX-R2	Fraction	0,50
ANOX-R4	Fraction	0,50
RAS Splitter 3	Fraction	0,50
WAS Splitter	Flowrate [Side]	175
RAS Splitter 1	Fraction	0,50
SCREENING Splitter	Flowrate [Side]	0
MBR Distribute 2	Fraction	0,50
INF Distributer 2	Fraction	0,50
ANOX-R3	Fraction	0,50
ANA-R2	Flow paced	25,00 %
RAS Splitter 2	Fraction	0,50

Table 34. Album page – Loads Summer operation

Elements	INF (including Mugeba)	GRIT	SCREENING	EFF	DEWATERED SLUDGE	FeCl3	POLYMER
Flow [m3/d]	5849,40	0,29	0,47	5841,91	7,38	0	0,65
Total suspended solids [kg /d]	2598,34	8,42	312,81	0,00	1664,27	0	7,93
Volatile suspended solids [kg /d]	2411,16	0,24	302,93	0,00	1312,11	0	7,88
ISS Total [kg /d]	187,18	8,18	9,88	0,00	352,17	0	0,05
BOD - Total Carbonaceous [kg /d]	2714,88	0,22	89,61	6,31	661,73	0	7,04
COD - Total [kg /d]	5196,61	0,44	405,64	178,40	1832,64	0	11,82
N - Total N [kg N/d]	512,99	0,03	8,72	62,29	112,78	0	0
P - Total P [kg P/d]	66,68	0,00	1,76	0,31	64,61	0	0
Total iron (all forms) [kg Me/d]	0	0,00	0,00	0,00	0,00	0	0

Table 35. Album page – Loads Winter operation

Elements	INF (including Mugeba)	GRIT	SCREENING	EFF	DEWATERED SLUDGE	FeCl3	POLYMER
Flow [m3/d]	582,90	0,03	0,05	582,45	1,08	0,05	0,65
Total suspended solids [kg /d]	213,98	1,81	21,64	0,00	131,82	0	7,93
Volatile suspended solids [kg /d]	176,26	0,02	19,68	0,00	69,34	0	7,88
ISS Total [kg /d]	37,71	1,80	1,96	0,00	62,48	0	0,05
BOD - Total Carbonaceous [kg /d]	206,43	0,02	6,48	0,37	22,51	0	6,75



COD - Total [kg /d]	388,97	0,03	27,57	17,34	98,38	0	11,82
N - Total N [kg N/d]	40,80	0,00	0,29	6,03	4,93	0	0
P - Total P [kg P/d]	5,42	0,00	0,10	0,43	4,90	0	0
Total iron (all forms) [kg Me/d]	0	0,00	0,02	0,00	7,48	7,50	0

9.4 Conclusions on the model results

The design is used to model the influent situation measured in 2019 under winter and summer conditions. Modelling results are according to the designed performance without the need of changing model parameters. The one parameter changed is a default setting for full nutrient removing WWTPs as applies to the MBR design. This data is suitable to be used in subsequent calculations of sea water modelling. The results can be used for further dynamic activated sludge modelling. The results are indicative for the operation at current loading conditions with the remark that actual operation may be different from what is here modelled.



10 Conclusions and recommendations

10.1 General conclusions

- From this study it is concluded that all relevant information is available to execute the study, including plant design data, process flow diagrams and influent data.
- In this study, data is collected and organized and made available in spreadsheets for further processing.
- Influent data is measured and suitable for modelling and design calculations.
- All data required to calculate the model influent characterization is available. Influent data is processed for modelling according to the influent specification method.
- A static model is developed using BioWin software based on the detailed design and measured average influent data.
- The model is completely based on default BioWin parameter setting and information from the detailed design.
- Static simulation results show that the model performs according to the effluent and design requirements both under winter and summer conditions.

10.2 Recommendation

- This study can be followed up by a dynamic evaluation. It is recommended to proceed with further development of the WWTP model taking in account the above conclusions.



Appendix 1. Project overview and planning

Sc.	Season	TER/OED/NOT	Flow/Load	Sewerage	WWTP	Sea	Comment
S1	Summer	TER	Max	■	■	X	No need to model sea due to 100% reuse of the effluent
S2		OED					
S3		NOT					
S4	Winter	TER/OED	Min	■	■	■ ¹	High risk on the sea due to no treatment and max flow/load (scenarios S3.1-S3.5)
W1		TER	Max	■	■	X	No need to model sea due to 100% reuse of the effluent
W2		OED					
W3		NOT					
W4	TER/OED	Min	■	■	■	X	No need to model sea due to 100% reuse of the effluent / UF MBR, and W2 in place

TER: Treated Effluent Reuse

OED: Offshore Emergency Discharge

NOT: No Treatment (Note¹: Seawater modelling in this high risk case will examine 4 sub-scenarios: S3.1 – S3.4, one WWTP out of operation at the time, and one worst case scenario: S3.5 with all 4 WWTP out of operation simultaneously, with optional dynamic simulation of day/night conditions, depending on data available).

Appendix 3. Layout Activated Sludge System

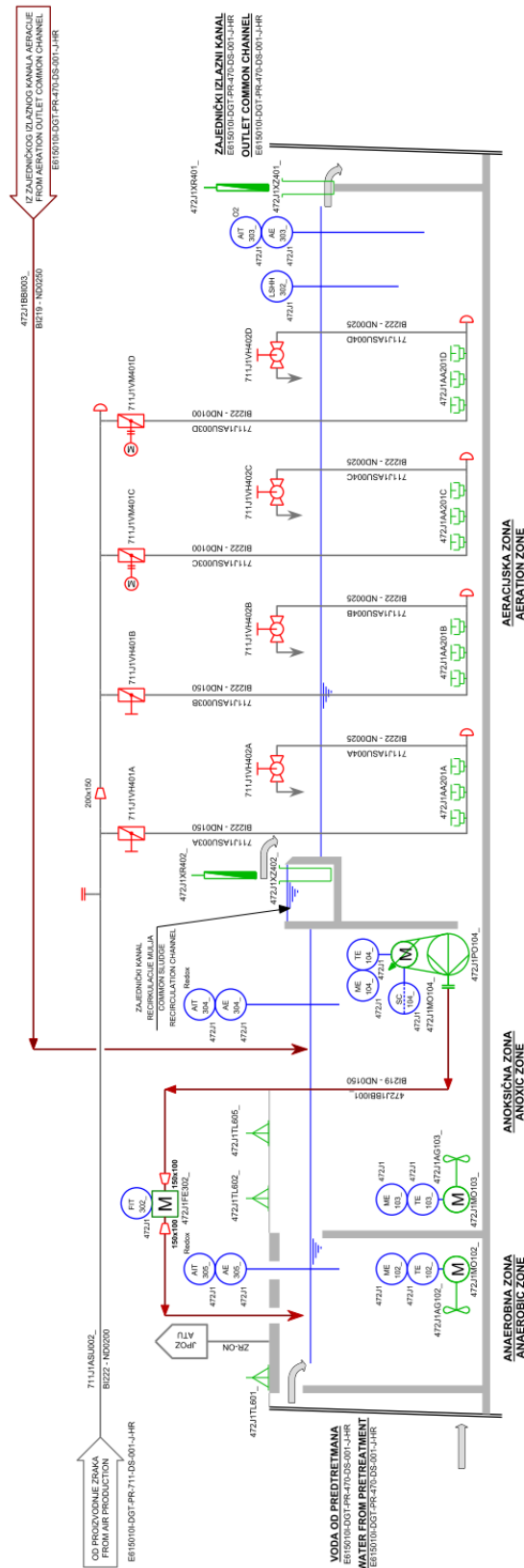

Appendix 4. BioWin Layout

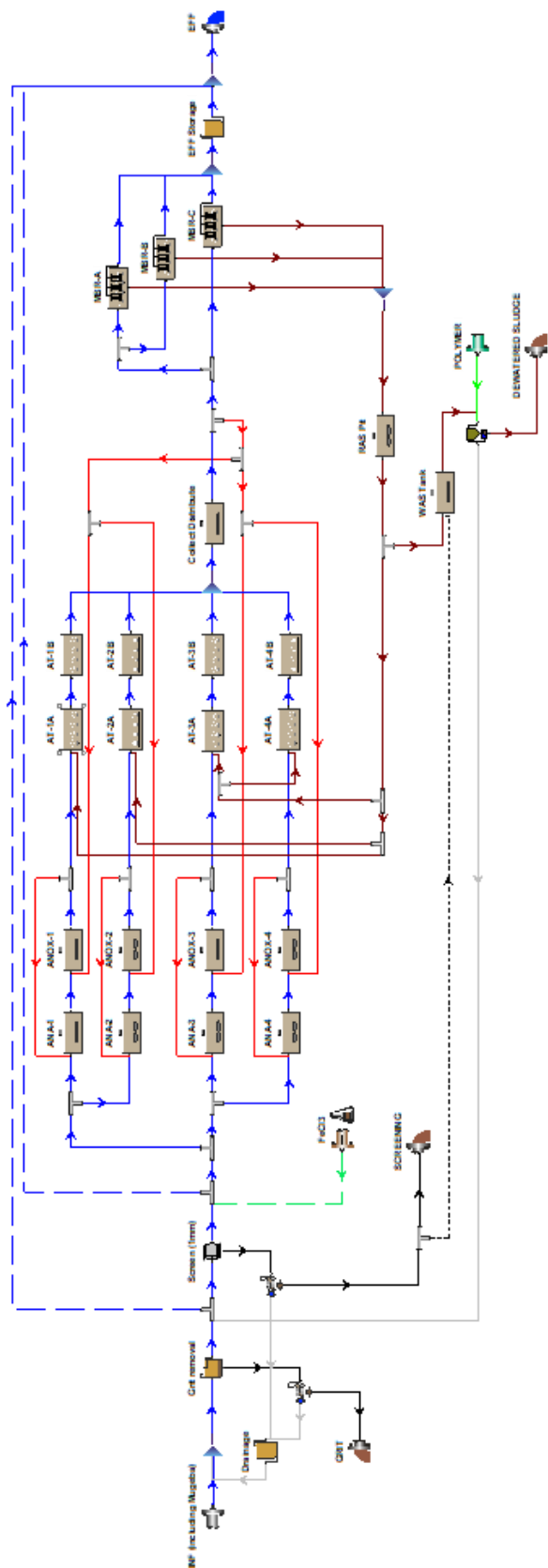

Appendix 5. Mass Balance: Design

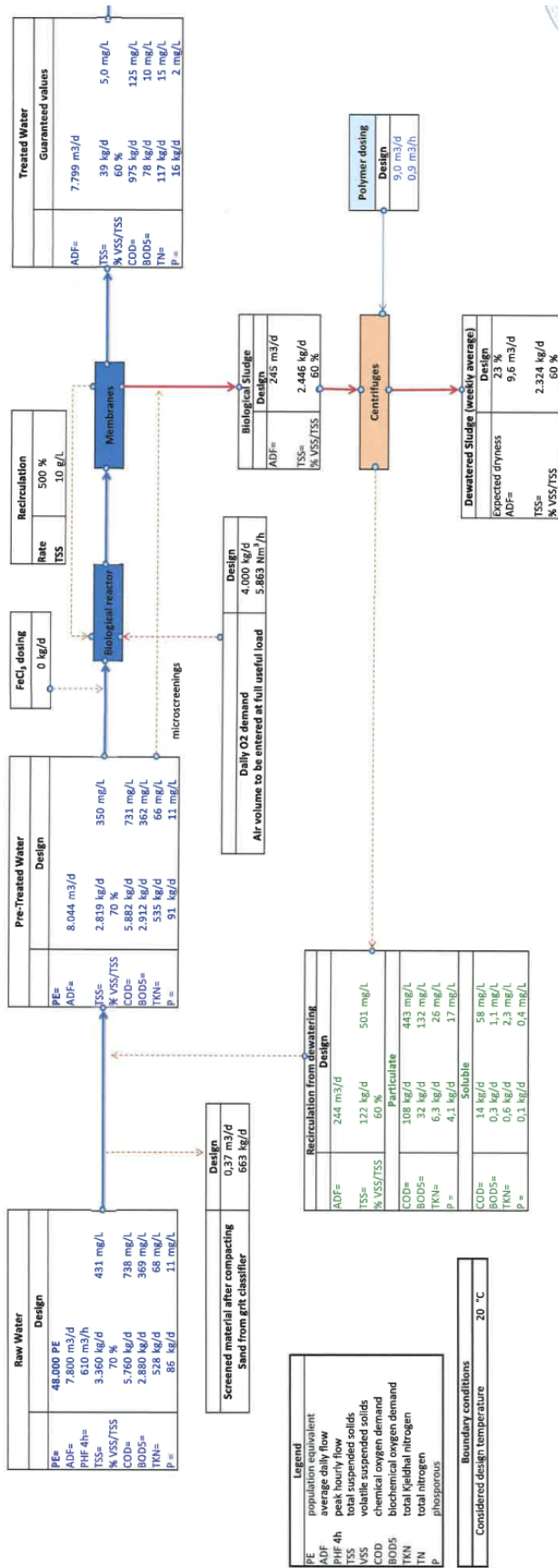

Appendix 6. Influent Concentrations Winter & Summer

Winter - Flow-Weighed Average Influent Concentration per WWTP				
	Lanterna	Vrsar	Poreč-North	Poreč-South
TSS (mgTSS/L) - Flow Proportional	254,8	354,2	596,0	364,6
VSS (mgVSS/L) - Flow Proportional	216,8	260,0	399,7	299,9
ISS (mgISS/L) - Flow Proportional	22,7	79,9	144,7	47,4
BOD (mgBOD/L) - Flow proportional	336,8	380,7	674,9	363,7
BODMF (mgBOD/L) - Flow proportional	154,2	239,8	428,3	152,2
TCOD (mgCOD/L) - Flow Proportional	612,5	737,9	1242,2	667,3
CODMF (mgCOD/L) - Flow Proportional	239,2	322,5	537,8	177,4
TN (mgN/L) - Flow Proportional	84,6	55,3	76,3	69,9
NH4 (mgN/L) - Flow Proportional	73,3	41,4	54,2	54,8
NO3 (mgN/L) - Flow Proportional	0,6	0,2	0,5	0,4
NO2 (mgN/L) - Flow Proportional	0,1	0,0	0,0	0,0
TP (mgP/L) - Flow Proportional	10,6	7,8	10,3	9,3
PO4 (mgP/L) - Flow Proportional	7,1	5,6	6,3	6,3

Summer - Flow-Weighed Influent Concentration per WWTP				
	Lanterna	Vrsar	Poreč-North	Poreč-South
TSS (mgTSS/L) - Flow Proportional	445,8	309,8	475,9	423,1
VSS (mgVSS/L) - Flow Proportional	416,4	282,2	423,5	392,6
ISS (mgISS/L) - Flow Proportional	29,4	27,6	52,5	30,5
BOD (mgBOD/L) - Flow proportional	489,3	460,1	496,4	467,2
BODMF (mgBOD/L) - Flow proportional	168,2	166,5	181,2	163,3
TCOD (mgCOD/L) - Flow Proportional	935,7	710,0	1059,6	888,4
CODMF (mgCOD/L) - Flow Proportional	244,4	222,2	314,5	231,4
TN (mgN/L) - Flow Proportional	95,1	72,4	83,1	87,7
NH4 (mgN/L) - Flow Proportional	69,5	54,9	59,6	67,4
NO3 (mgN/L) - Flow Proportional	0,4	0,5	0,5	0,5
NO2 (mgN/L) - Flow Proportional	0,1	0,0	0,0	0,0
TP (mgP/L) - Flow Proportional	13,5	10,3	11,1	11,4
PO4 (mgP/L) - Flow Proportional	6,8	5,0	6,8	6,3



Appendix 7. Influent Loads Winter & Summer

Winter - Average Influent Loads per WWTP				
	Lanterna	Vrsar	Poreč-North	Poreč-South
Flow (m3/d)	238,9	393,5	2106,4	582,9
TSS (kgTSS/d)	60,9	139,4	1485,3	244,5
VSS (kgVSS/d)	54,4	104,8	1088,1	212,8
ISS (kgISS/d)	5,7	32,2	393,9	33,6
BOD (kgBOD/d)	80,4	149,8	1421,7	212,0
BODMF (kgBOD/d)	36,8	94,4	902,3	88,7
TCOD (kgCOD/d)	146,3	290,4	3052,8	447,5
CODMF (kgCOD/d)	57,1	126,9	1321,7	119,0
TN (kgN/d)	20,9	21,7	204,5	47,6
NH4 (kgN/d)	17,5	16,3	135,0	36,8
NO3 (kgN/d)	0,1	0,1	1,0	0,2
NO2 (kgN/d)	0,0	0,0	0,1	0,0
TP (kgP/d)	2,5	3,1	21,7	5,4
PO4 (kgP/d)	1,7	2,2	15,6	4,2

Summer - Average Influent Loads per WWTP				
	Lanterna	Vrsar	Poreč-North	Poreč-South
Flow (m3/d)	2736,6	1914,6	4429,6	5849,4
TSS (kgTSS/d)	1220,0	664,4	2133,6	2598,5
VSS (kgVSS/d)	1139,6	605,2	1898,7	2411,4
ISS (kgISS/d)	80,5	60,9	235,4	187,0
BOD (kgBOD/d)	1339,0	880,9	2198,8	2733,0
BODMF (kgBOD/d)	460,3	318,7	802,7	955,1
TCOD (kgCOD/d)	2560,5	1522,6	4750,2	5456,6
CODMF (kgCOD/d)	668,9	476,4	1410,0	1421,3
TN (kgN/d)	260,2	155,3	372,7	538,8
NH4 (kgN/d)	190,2	117,8	267,3	413,9
NO3 (kgN/d)	1,2	0,9	2,1	2,8
NO2 (kgN/d)	0,2	0,0	0,1	0,1
TP (kgP/d)	36,9	19,7	49,0	66,4
PO4 (kgP/d)	18,7	10,6	30,4	38,8



Appendix 8. Design Loading 2045 Prognosis

Inhabitant Specific Loads in g/PE/d		
Parameter	Unit	Wastewater Quality Produced per PE
BOD5	gBOD/PE/d	60
TCOD	gCOD/PE/d	120
TSS	gTSS/PE/d	70
TKN	gN/PE/d	11
TP	gP/PE/d	1,8

WWTP Poreč-South - Data for Poreč-South WWTP sizing				
	Population (PE)	Tourist Overnights Average	Households	Non-Households
Months	2011	2009-2011	2009-2011 (m3/month)	2009-2011 (m3/month) ²
1	4590	7700	14400	15600
2	4590	6900	13700	15000
3	4590	16500	12700	17400
4	4590	76500	15800	42900
5	4590	191900	21300	98100
6	4590	393900	25500	140600
7	4590	676200	33500	208700
8	4590	732200	37200	215600
9	4590	373700	35600	150200
10	4590	51400	16300	49100
11	4590	4800	13700	15800
12	4590	11400	11500	10200
Estimated growth of tourist overnights from 2011 to 2045				0,15
Permanent population 2045				5578



Appendix 9. BioWin Model Influent Specification – Sumer

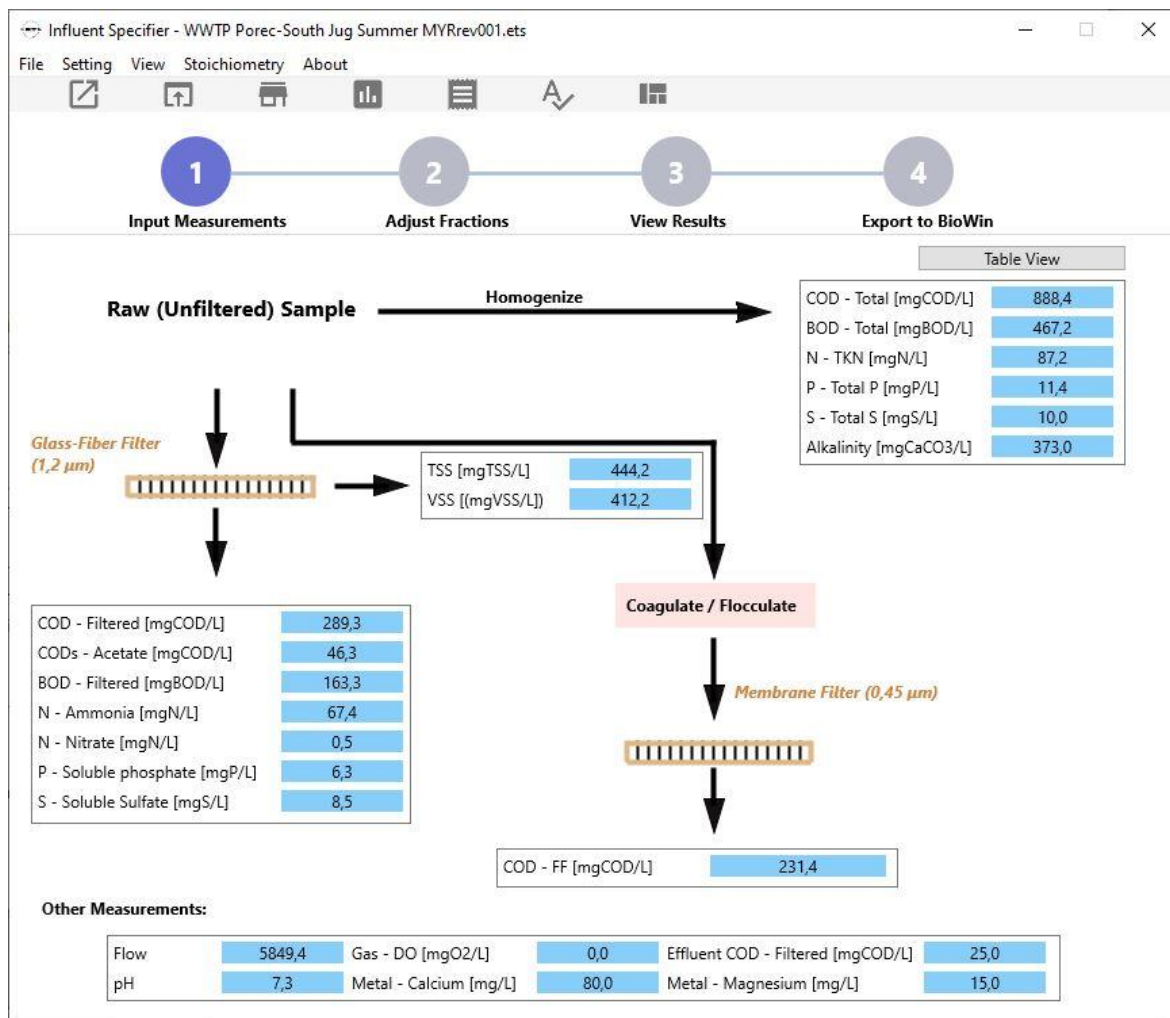

Influent Specifier - WWTP Porec-South Jug Summer MYRrev001.ets

File Setting View Stoichiometry About

Input Measurements Adjust Fractions View Results Export to BioWin

Fraction / Parameter Estimates			Fraction Calculation Results			
Name	Default	Estimate	Influent Values	Measured	Calculated	Match Status
COD Fractions			COD - Total	888,4000	888,4000	-
Fbs	0,1600	0,2323	COD - Particulate	599,1000	599,1000	Excellent
Fac	0,1500	0,2243	COD - Filtered	289,3000	289,3000	Excellent
Fxs	0,6388	0,6075	COD - FF	231,4000	231,4000	Excellent
Fxsp	0,7500	0,8927	BOD - Total Carbonaceous	467,2000	464,1166	Excellent
Fbiomass	0,0212	0,0265	BOD - Filtered Carbonaceous	163,3000	163,9156	Excellent
Fus	0,0500	0,0281	VSS	412,2000	412,1785	Excellent
Fup	0,1300	0,1055	TSS	444,2000	444,1785	Excellent
Cellulose (Note...)	0,5000	0,5930				
Non-Cellulose	0,5000	0,4070				
COD : VSS			Influent CODp : VSS	1,4534	1,4535	Excellent
Particulate Biodegradable COD : VSS	1,6327	1,5000	Influent Total COD : cBOD	1,9015	1,9142	Excellent
Particulate Inert COD : VSS	1,6000	1,1000	VSS : TSS	0,9280	0,9280	Excellent
Cellulose COD : VSS	1,4000	1,4000				
BOD Model Parameters (Note...)						
k1 for CODc - Xsc	0,5000	0,1395				
k2 for CODp - Xsp	0,5000	0,5814				



Influent Specifier - WWTP Porec-South Jug Summer MYRrev001.ets

File Setting View Stoichiometry About

Input Measurements Adjust Fractions **3 View Results** 4 Export to BioWin

COD/BOD Calculation Results		P, N and ISS Calculation Results	
Name	Value	Name	Value
COD Calculation Results		P Calculation Results	
B - Z [mg/L]	23,5426	P in biomass [mgP/L]	0,5179
CODc - Xsc [mg/L]	57,9000	P - Particulate degradable [mgP/L]	4,5350
CODp - Xsp [mg/L]	481,8312	P - Particulate undegradable [mgP/L]	0,0381
CODp - (Xu + Xuc) [mg/L]	93,7262	P - Releasable stored polyP [mgP/L]	0,0089
CODs - Sa [mg/L]	46,3000	P - Soluble phosphate [mgP/L]	6,3000
CODs - Sc [mg/L]	160,1000	Measured Total P [mgP/L]	11,4000
CODs - Su [mg/L]	25,0000		
		N Calculation Results	
COD Total-check [mg/L]	888,4000	N in biomass [mgN/L]	1,6480
		N - Ammonia [mgN/L]	67,4000
COD - Particulate [mg/L]	599,1000	N - Particulate degradable organic [mgN/L]	2,3783
COD - Slowly Biodegradable [mg/L]	539,7312	N - Particulate undegradable organic [mgN/	2,6703
COD - Readily Biodegradable [mg/L]	206,4000	N - Soluble degradable organic [mgN/L]	12,2313
		N - Soluble undegradable organic [mgN/L]	0,8720
Sol. COD fraction	0,3256	Measured TKN [mgN/L]	87,2000
		ISS Calculation Results	
BOD Calculation Results		ISS of Biomass [mgISS/L]	1,9588
BODrbcod [mg/L]	147,1327	ISS of Influent Inorganic SS [mgISS/L]	27,9533
BODxsc [mg/L]	287,0397	ISS of PolyP [mgISS/L]	0,0247
BODxsp [mg/L]	16,7829	ISS of Xsp [mgISS/L]	2,0632
BODhet [mg/L]	13,1614	Measured ISS [mgISS/L]	32,0000
BODtotal [mg/L]	464,1166		



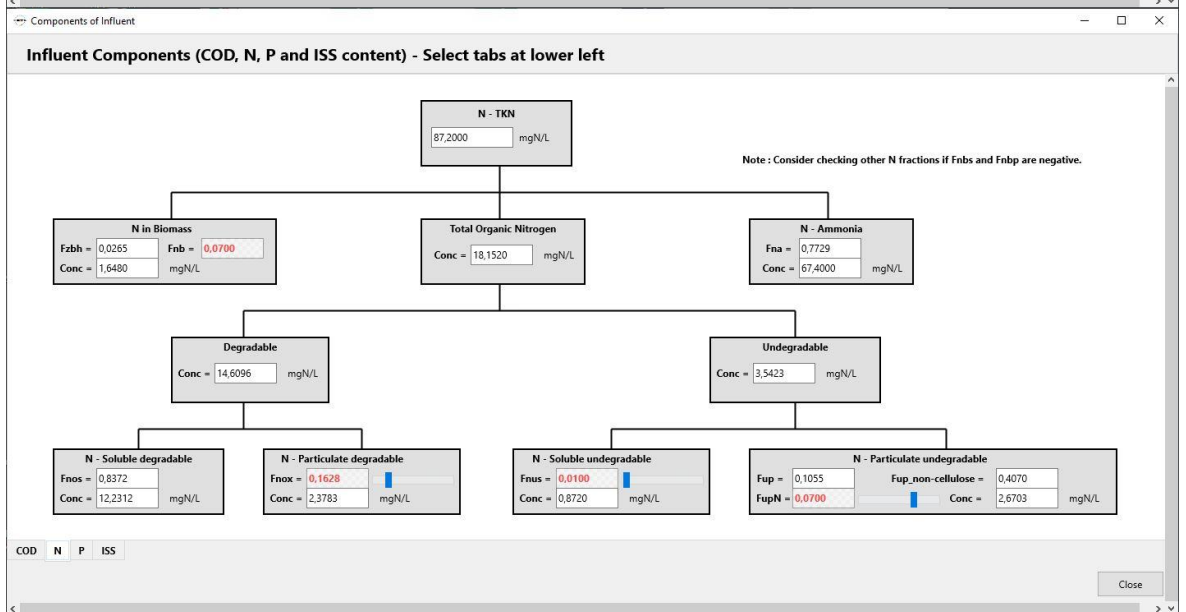
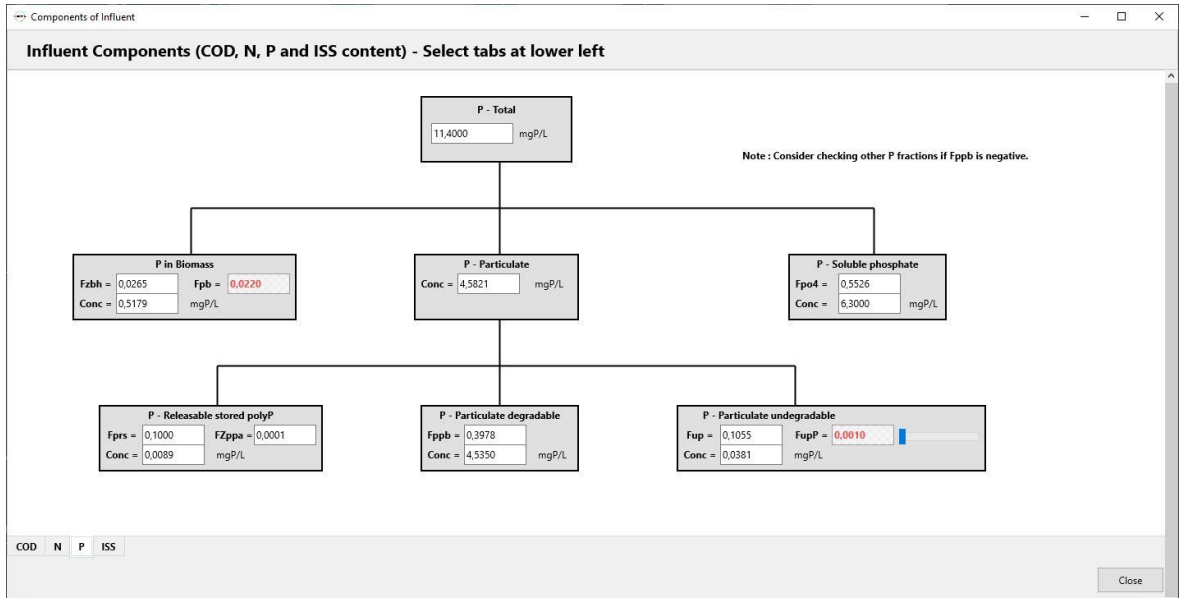

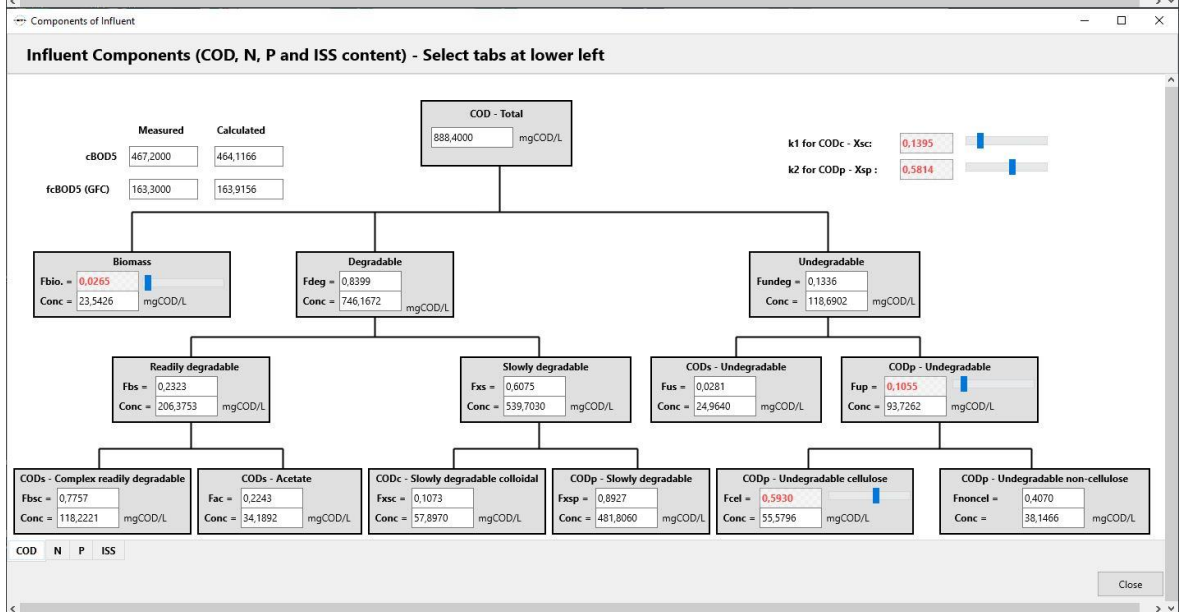
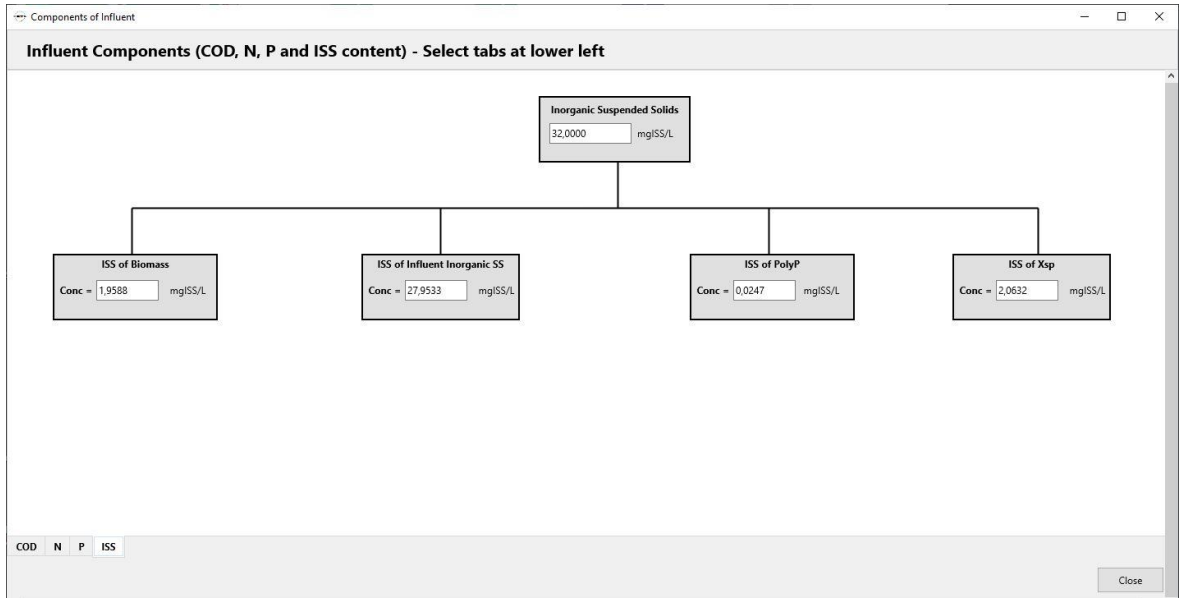

Appendix 10. BioWin Model Influent Specification – Winter

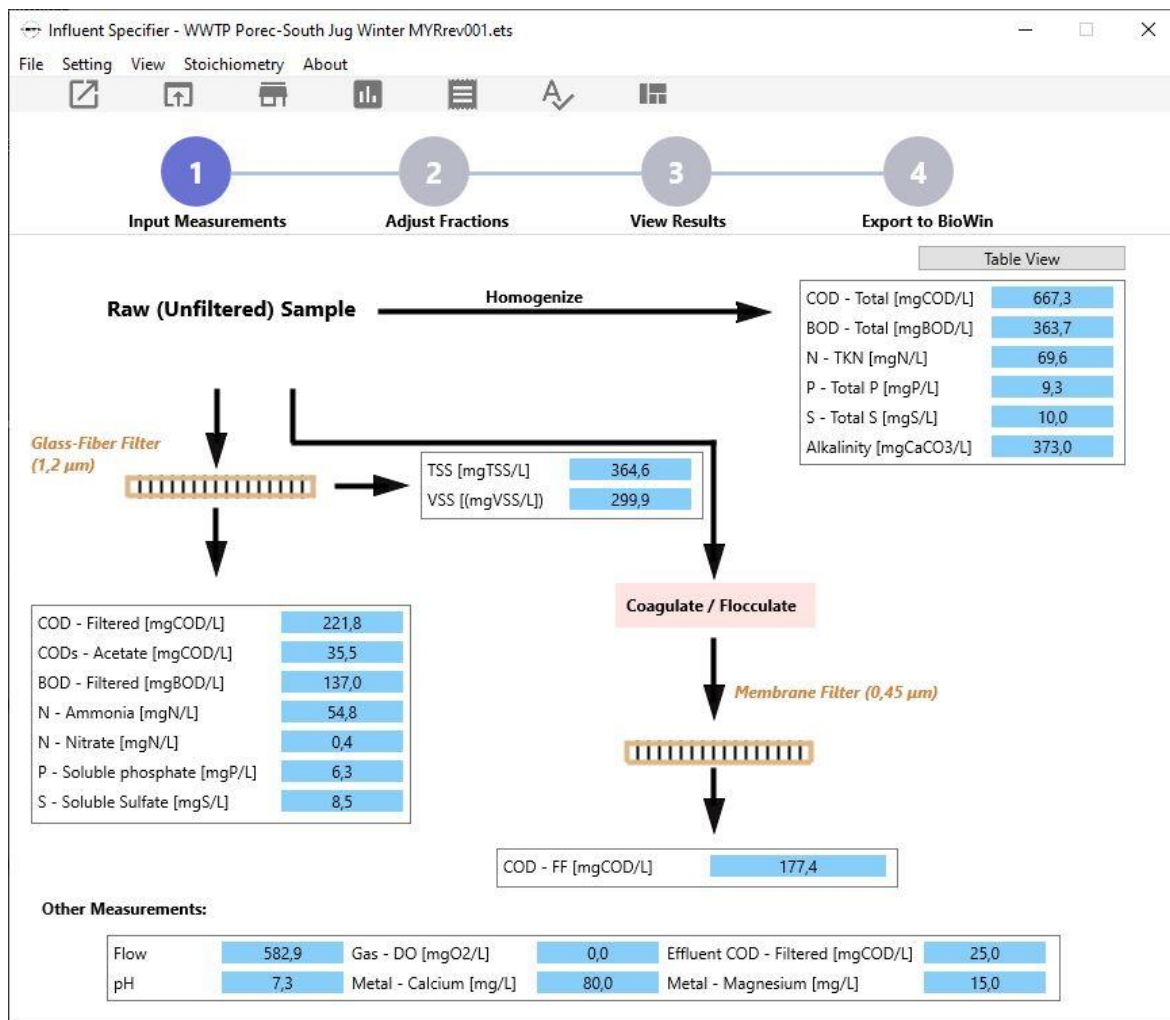

Influent Specifier - WWTP Porec-South Jug Winter MYRrev001.ets

File Setting View Stoichiometry About

Input Measurements Adjust Fractions View Results Export to BioWin

Fraction / Parameter Estimates			Fraction Calculation Results			
Name	Default	Estimate	Influent Values	Measured	Calculated	Match Status
COD Fractions			COD - Total	667,3000	667,3000	-
Fbs	0,1600	0,2284	COD - Particulate	445,5000	445,5000	Excellent
Fac	0,1500	0,2329	COD - Filtered	221,8000	221,8000	Excellent
Fxs	0,6388	0,6182	COD - FF	177,4000	177,4000	Excellent
Fxsp	0,7500	0,8924	BOD - Total Carbonaceous	363,7000	354,1566	Excellent
Fbiomass	0,0212	0,0265	BOD - Filtered Carbonaceoi	137,0000	134,0358	Excellent
Fus	0,0500	0,0375	VSS	299,9000	302,4022	Excellent
Fup	0,1300	0,0895	TSS	364,6000	367,1022	Excellent
Cellulose (Note...)	0,5000	0,8372				
Non-Cellulose	0,5000	0,1628				
COD : VSS			Influent CODp : VSS	1,4855	1,4732	Excellent
Particulate Biodegradable COD : VSS	1,6327	1,5000	Influent Total COD : cBOD	1,8348	1,8842	Excellent
Particulate Inert COD : VSS	1,6000	1,1000	VSS : TSS	0,8225	0,8238	Excellent
Cellulose COD : VSS	1,4000	1,4000				
BOD Model Parameters (Note...)						
k1 for CODc - Xsc	0,5000	0,5000				
k2 for CODp - Xsp	0,5000	0,5000				



Influent Specifier - WWTP Porec-South Jug Winter MYRrev001.ets

File Setting View Stoichiometry About

Input Measurements Adjust Fractions **3** View Results Export to BioWin 4

COD/BOD Calculation Results		P, N and ISS Calculation Results	
Name	Value	Name	Value
COD Calculation Results		P Calculation Results	
B - Z [mg/L]	17,6834	P in biomass [mgP/L]	0,3890
CODc - Xsc [mg/L]	44,4000	P - Particulate degradable [mgP/L]	2,5946
CODp - Xsp [mg/L]	368,0932	P - Particulate undegradable [mgP/L]	0,0097
CODp - (Xu + Xuc) [mg/L]	59,7233	P - Releasable stored polyP [mgP/L]	0,0067
CODs - Sa [mg/L]	35,5000	P - Soluble phosphate [mgP/L]	6,3000
CODs - Sc [mg/L]	116,9000	Measured Total P [mgP/L]	9,3000
CODs - Su [mg/L]	25,0000		
		N Calculation Results	
COD Total-check [mg/L]	667,3000	N in biomass [mgN/L]	1,2378
		N - Ammonia [mgN/L]	54,8000
COD - Particulate [mg/L]	445,5000	N - Particulate degradable organic [mgN/L]	1,9837
COD - Slowly Biodegradable [mg/L]	412,4932	N - Particulate undegradable organic [mgN/	0,6806
COD - Readily Biodegradable [mg/L]	152,4000	N - Soluble degradable organic [mgN/L]	10,2017
		N - Soluble undegradable organic [mgN/L]	0,6960
Sol. COD fraction	0,3324	Measured TKN [mgN/L]	69,6000
		ISS Calculation Results	
BOD Calculation Results		ISS of Biomass [mgISS/L]	1,4713
BODrbcod [mg/L]	108,6769	ISS of Influent Inorganic SS [mgISS/L]	61,6340
BODxsc [mg/L]	210,2350	ISS of PolyP [mgISS/L]	0,0186
BODxsp [mg/L]	25,3589	ISS of Xsp [mgISS/L]	1,5762
BODhet [mg/L]	9,8858	Measured ISS [mgISS/L]	64,7000
BODtotal [mg/L]	354,1566		



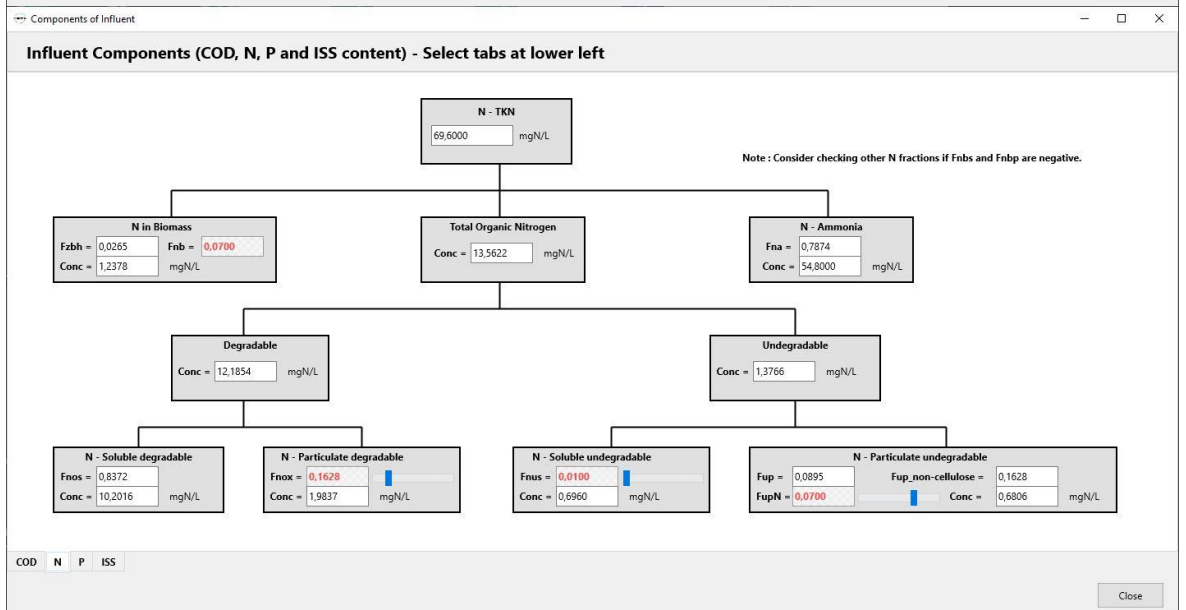
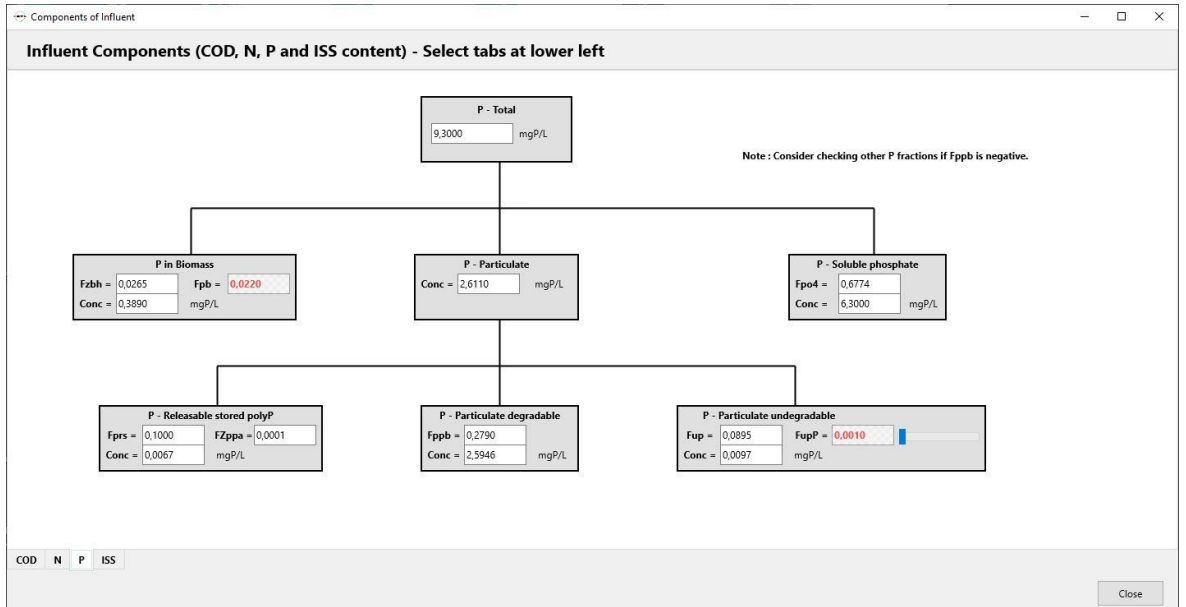

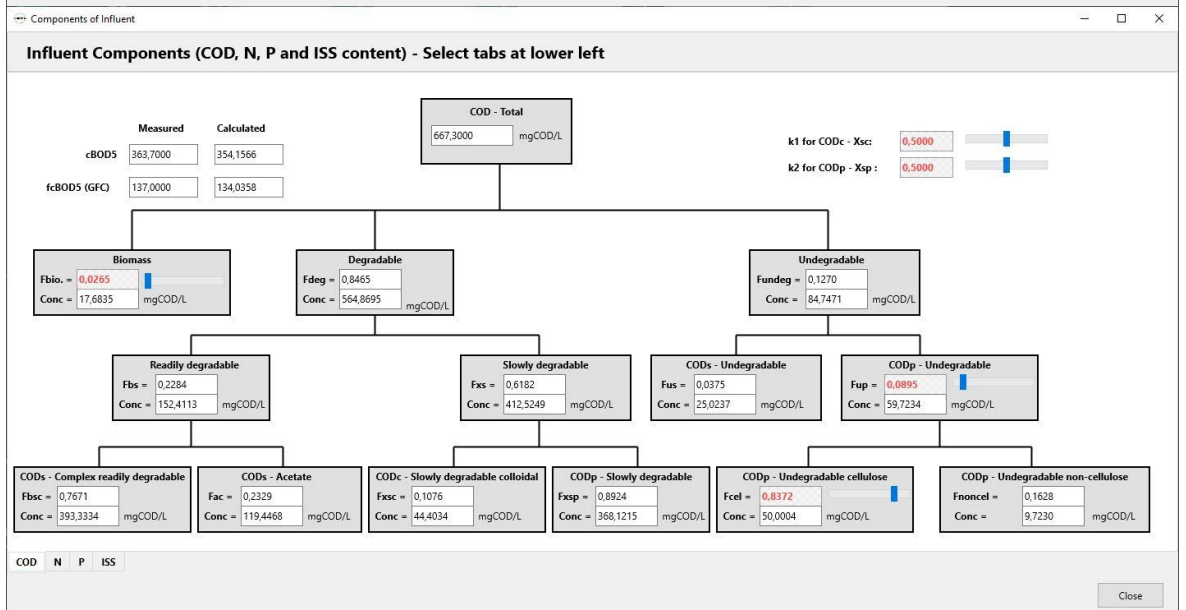
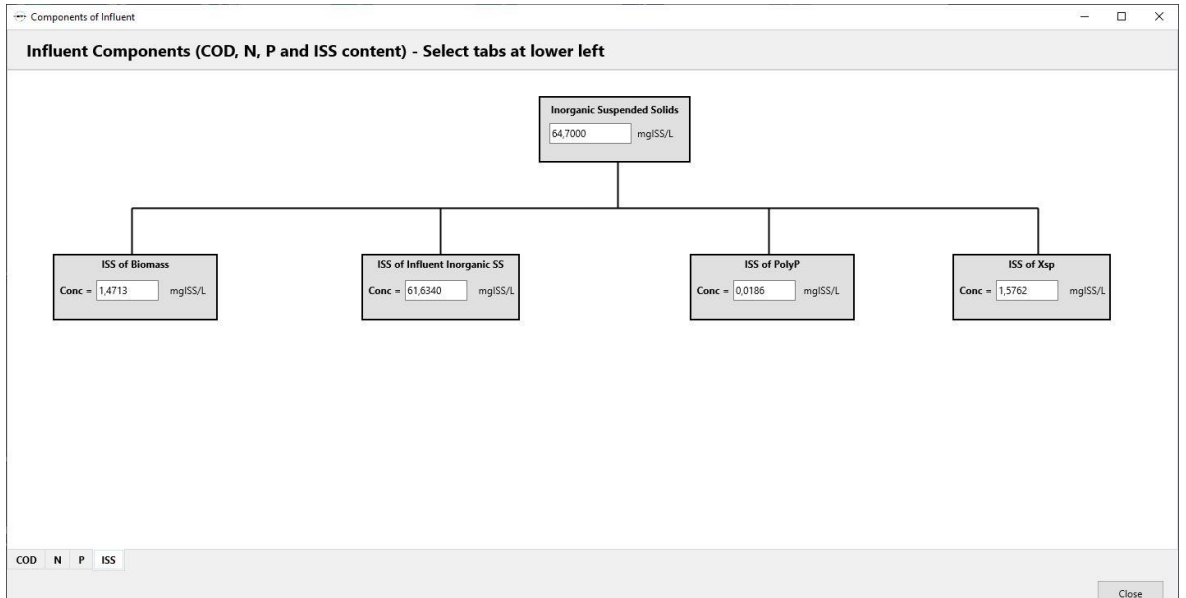

Appendix 11: BioWin user and configuration data – Winter Load

Project details

Project name:

Steady State Design Retrofit Average Flow Weighed Influent Data Summer 2019

Project ref.: Winter Load

Plant name: WWTP Porec-South Jug (POSO)

Username: ASM Design

Created: 9-3-2021

Saved: 9-5-2021

Steady state solution

Temperature: 12,0°C

Flowsheet

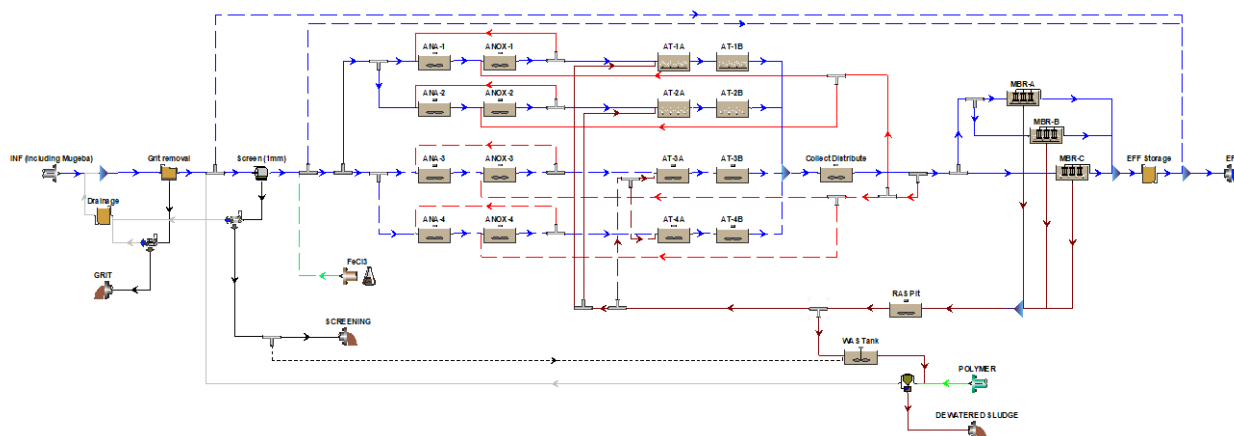

Configuration information for all Bioreactor units

Physical data



Element name	Volume [m3]	Area [m2]	Depth [m]	# of diffusers
ANA-1	200,0000	36,3636	5,500	Un-aerated
ANOX-1	175,0000	31,8182	5,500	Un-aerated
AT-1A	180,0000	32,7273	5,500	163
ANA-3	200,0000	36,3636	5,500	Un-aerated
ANOX-3	175,0000	31,8182	5,500	Un-aerated
AT-3A	180,0000	32,7273	5,500	Un-aerated
ANA-4	200,0000	36,3636	5,500	Un-aerated
ANOX-4	175,0000	31,8182	5,500	Un-aerated
AT-4A	180,0000	32,7273	5,500	Un-aerated
Collect Distribute	198,0000	36,0000	5,500	Un-aerated
RAS Pit	81,8230	40,9115	2,000	Un-aerated
WAS Tank	150,0000	2,8302	53,000	Un-aerated
ANA-2	200,0000	36,3636	5,500	Un-aerated
ANOX-2	175,0000	31,8182	5,500	Un-aerated
AT-2A	180,0000	32,7273	5,500	163
AT-1B	180,0000	32,7273	5,500	163
AT-2B	180,0000	32,7273	5,500	163
AT-3B	180,0000	32,7273	5,500	Un-aerated
AT-4B	180,0000	32,7273	5,500	Un-aerated

Operating data Average (flow/time weighted as required)

Element name	Average DO Setpoint [mg/L]
ANA-1	0
ANOX-1	0
AT-1A	0,5
ANA-3	0
ANOX-3	0
AT-3A	0
ANA-4	0
ANOX-4	0
AT-4A	0
Collect Distribute	0
RAS Pit	0
WAS Tank	0
ANA-2	0
ANOX-2	0
AT-2A	0,5



AT-1B	1,5
AT-2B	1,5
AT-3B	0
AT-4B	0

Aeration equipment parameters

Element name	k_1 in C = $k_1(PC)^{0.25} + k_2$	k_2 in C = $k_1(PC)^{0.25} + k_2$	Y in $Kla = C U_{sg} \cdot Y - U_{sg}$ in [m ³ /(m ² d)]	Area of one diffuser	Diffuser mounting height	Min. air flow rate per diffuser m ³ /hr (20C, 1 atm)	Max. air flow rate per diffuser m ³ /hr (20C, 1 atm)	'A' in diffuser pressure drop = A + $B^*(Qa/Diff)^2$ + $C^*(Qa/Diff)^2$	'B' in diffuser pressure drop = A + $B^*(Qa/Diff)^2$ + $C^*(Qa/Diff)^2$	'C' in diffuser pressure drop = A + $B^*(Qa/Diff)^2$ + $C^*(Qa/Diff)^2$
ANA-1	1,2400	0,8960	0,8880	0,0380	0,2500	0,5000	10,0000	3,0000	0	0
ANOX-1	1,2400	0,8960	0,8880	0,0380	0,2500	0,5000	10,0000	3,0000	0	0
AT-1A	1,2400	0,8960	0,8880	0,0380	0,2500	0,5000	10,0000	3,0000	0	0
ANA-3	1,2400	0,8960	0,8880	0,0380	0,2500	0,5000	10,0000	3,0000	0	0
ANOX-3	1,2400	0,8960	0,8880	0,0380	0,2500	0,5000	10,0000	3,0000	0	0
AT-3A	1,2400	0,8960	0,8880	0,0380	0,2500	0,5000	10,0000	3,0000	0	0
ANA-4	1,2400	0,8960	0,8880	0,0380	0,2500	0,5000	10,0000	3,0000	0	0
ANOX-4	1,2400	0,8960	0,8880	0,0380	0,2500	0,5000	10,0000	3,0000	0	0
AT-4A	1,2400	0,8960	0,8880	0,0380	0,2500	0,5000	10,0000	3,0000	0	0
Collect Distribute	1,2400	0,8960	0,8880	0,0380	0,2500	0,5000	10,0000	3,0000	0	0
RAS Pit	1,2400	0,8960	0,8880	0,0380	0,2500	0,5000	10,0000	3,0000	0	0
WAS Tank	1,2400	0,8960	0,8880	0,0380	0,2500	0,5000	10,0000	3,0000	0	0
ANA-2	1,2400	0,8960	0,8880	0,0380	0,2500	0,5000	10,0000	3,0000	0	0
ANOX-2	1,2400	0,8960	0,8880	0,0380	0,2500	0,5000	10,0000	3,0000	0	0
AT-2A	1,2400	0,8960	0,8880	0,0380	0,2500	0,5000	10,0000	3,0000	0	0
AT-1B	1,2400	0,8960	0,8880	0,0380	0,2500	0,5000	10,0000	3,0000	0	0
AT-2B	1,2400	0,8960	0,8880	0,0380	0,2500	0,5000	10,0000	3,0000	0	0
AT-3B	1,2400	0,8960	0,8880	0,0380	0,2500	0,5000	10,0000	3,0000	0	0
AT-4B	1,2400	0,8960	0,8880	0,0380	0,2500	0,5000	10,0000	3,0000	0	0

Configuration information for all Bioreactor - Membrane units

Physical data



Element name	Volume [m3]	Area [m2]	Depth [m]	# of diffusers	# of cassettes	Displaced volume / cassette [m3/cassette]	Membrane area / cassette [m2/cassette]	Total displaced volume [m3]	Membrane surface area [m2]
MBR-A	75,0000	13,6364	5,500	150	3,00	1,690	1650,00	5,07	4950,00
MBR-B	75,0000	13,6364	5,500	102	3,00	1,690	1100,00	5,07	3300,00
MBR-C	75,0000	13,6364	5,500	102	3,00	1,690	1100,00	5,07	3300,00

Operating data Average (flow/time weighted as required)

Element name	Split method	Average Split specification
MBR-A	Flow paced	33,00 %
MBR-B	Flow paced	33,00 %
MBR-C	Flow paced	33,00 %

Element name	Average Air flow rate [m3/hr (20C, 1 atm)]
MBR-A	980,0
MBR-B	980,0
MBR-C	980,0

Aeration equipment parameters

Element name	k_1 in C = $k_1(PC)^{0.25} + k_2$	k_2 in C = $k_1(PC)^{0.25} + k_2$	Y in $Kla = C U_{sg} \cdot Y - U_{sg}$ in [m3/(m2 d)]	Area of one diffuser	Diffuser mounting height	Min. air flow rate per diffuser m3/hr (20C, 1 atm)	Max. air flow rate per diffuser m3/hr (20C, 1 atm)	'A' in diffuser pressure drop = A + $B^*(Qa/Diff)^2 + C^*(Qa/Diff)^2$	'B' in diffuser pressure drop = A + $B^*(Qa/Diff)^2 + C^*(Qa/Diff)^2$	'C' in diffuser pressure drop = A + $B^*(Qa/Diff)^2 + C^*(Qa/Diff)^2$
MBR-A	0,0500	0,3800	1,0000	0,0500	0,2500	2,0000	50,0000	1,0000	0	0
MBR-B	0,0500	0,3800	1,0000	0,0500	0,2500	2,0000	50,0000	1,0000	0	0
MBR-C	0,0500	0,3800	1,0000	0,0500	0,2500	2,0000	50,0000	1,0000	0	0

Element name	Surface pressure [kPa]	Fractional effective saturation depth (Fed) [-]
--------------	------------------------	---



MBR-A	101,3250	0,3000
MBR-B	101,3250	0,3000
MBR-C	101,3250	0,3000

Element name	Supply gas CO2 content [vol. %]	Supply gas O2 [vol. %]	Off-gas CO2 [vol. %]	Off-gas O2 [vol. %]	Off-gas H2 [vol. %]	Off-gas NH3 [vol. %]	Off-gas CH4 [vol. %]	Off-gas N2O [vol. %]	Surface turbulence factor [-]
MBR-A	0,0400	20,9500	1,2000	19,9000	0	0	0	0	2,0000
MBR-B	0,0400	20,9500	1,2000	19,9000	0	0	0	0	2,0000
MBR-C	0,0400	20,9500	1,2000	19,9000	0	0	0	0	2,0000

Configuration information for all Effluent units

Configuration information for all Separator - Grit tank units

Physical data

Element name	Volume [m3]	Area [m2]	Depth [m]
Grit removal	3200,4000	12,6000	254,000

Operating data Average (flow/time weighted as required)

Element name	Split method	Average Split specification
Grit removal	Flow paced	0,01 %

Element name	Percent removal	Blanket fraction
Grit removal	5,00	0,10

Configuration information for all Influent - COD units



Operating data Average (flow/time weighted as required)

Element name	INF (including Mugeba)
Flow	582,9
COD - Total mgCOD/L	667,30
N - Total Kjeldahl Nitrogen mgN/L	69,60
P - Total P mgP/L	9,30
S - Total S mgS/L	10,00
N - Nitrate mgN/L	0,40
pH	7,30
Alkalinity mmol/L	7,46
ISS Total mgISS/L	64,70
Metal soluble - Calcium mg/L	80,00
Metal soluble - Magnesium mg/L	15,00
Gas - Dissolved oxygen mg/L	0

Element name	INF (including Mugeba)
Fbs - Readily biodegradable (including Acetate) [gCOD/g of total COD]	0,2284
Fac - Acetate [gCOD/g of readily biodegradable COD]	0,2329
Fxsp - Non-colloidal slowly biodegradable [gCOD/g of slowly degradable COD]	0,8924
Fus - Unbiodegradable soluble [gCOD/g of total COD]	0,0375
Fup - Unbiodegradable particulate [gCOD/g of total COD]	0,0895
Fcel - Cellulose fraction of unbiodegradable particulate [gCOD/gCOD]	0,8372
Fna - Ammonia [gNH ₃ -N/gTKN]	0,7874
Fnox - Particulate organic nitrogen [gN/g Organic N]	0,1628
Fnus - Soluble unbiodegradable TKN [gN/gTKN]	0,0100
FupN - N:COD ratio for unbiodegradable part. COD [gN/gCOD]	0,0700
Fpo4 - Phosphate [gPO ₄ -P/gTP]	0,6774
FupP - P:COD ratio for unbiodegradable part. COD [gP/gCOD]	1,000E-3
Fsr - Reduced sulfur [H ₂ S] [gS/gS]	0,1500
FZbh - Ordinary heterotrophic COD fraction [gCOD/g of total COD]	0,0253
FZbm - Methyloctrophic COD fraction [gCOD/g of total COD]	1,000E-4
FZao - Ammonia oxidizing COD fraction [gCOD/g of total COD]	1,000E-4
FZno - Nitrite oxidizing COD fraction [gCOD/g of total COD]	1,000E-4
FZaao - Anaerobic ammonia oxidizing COD fraction [gCOD/g of total COD]	1,000E-4
FZppa - Phosphorus accumulating COD fraction [gCOD/g of total COD]	1,000E-4
FZpa - Propionic acetogenic COD fraction [gCOD/g of total COD]	1,000E-4
FZam - Acetoclastic methanogenic COD fraction [gCOD/g of total COD]	1,000E-4
FZhm - Hydrogenotrophic methanogenic COD fraction [gCOD/g of total COD]	1,000E-4



FZso - Sulfur oxidizing COD fraction [gCOD/g of total COD]	1,000E-4
FZsrpa - Sulfur reducing propionic acetogenic COD fraction [gCOD/g of total COD]	1,000E-4
FZsra - Sulfur reducing acetotrophic COD fraction [gCOD/g of total COD]	1,000E-4
FZsrh - Sulfur reducing hydrogenotrophic COD fraction [gCOD/g of total COD]	1,000E-4
FZe - Endogenous products COD fraction [gCOD/g of total COD]	0

Configuration information for all Input - Iron (ferric) units

Operating data Average (flow/time weighted as required)

Element name	FeCl3
Biomass - Ordinary heterotrophic [mgCOD/L]	0
Biomass - Methyloctrophic [mgCOD/L]	0
Biomass - Ammonia oxidizing [mgCOD/L]	0
Biomass - Nitrite oxidizing [mgCOD/L]	0
Biomass - Anaerobic ammonia oxidizing [mgCOD/L]	0
Biomass - Phosphorus accumulating [mgCOD/L]	0
Biomass - Propionic acetogenic [mgCOD/L]	0
Biomass - Acetoclastic methanogenic [mgCOD/L]	0
Biomass - Hydrogenotrophic methanogenic [mgCOD/L]	0
Biomass - Endogenous products [mgCOD/L]	0
CODp - Slowly degradable particulate [mgCOD/L]	0
CODp - Slowly degradable colloidal [mgCOD/L]	0
CODp - Degradable external organics [mgCOD/L]	0
CODp - Undegradable non-cellulose [mgCOD/L]	0
CODp - Undegradable cellulose [mgCOD/L]	0
N - Particulate degradable organic [mgN/L]	0
P - Particulate degradable organic [mgP/L]	0
N - Particulate degradable external organics [mgN/L]	0
P - Particulate degradable external organics [mgP/L]	0
N - Particulate undegradable [mgN/L]	0
P - Particulate undegradable [mgP/L]	0
CODp - Stored PHA [mgCOD/L]	0
P - Releasable stored polyP [mgP/L]	0
P - Unreleasable stored polyP [mgP/L]	0
CODs - Complex readily degradable [mgCOD/L]	0
CODs - Acetate [mgCOD/L]	0
CODs - Propionate [mgCOD/L]	0



CODs - Methanol [mgCOD/L]	0
Gas - Dissolved hydrogen [mgCOD/L]	0
Gas - Dissolved methane [mg/L]	0
N - Ammonia [mgN/L]	0
N - Soluble degradable organic [mgN/L]	0
Gas - Dissolved nitrous oxide [mgN/L]	0
N - Nitrite [mgN/L]	0
N - Nitrate [mgN/L]	0
Gas - Dissolved nitrogen [mgN/L]	0
P - Soluble phosphate [mgP/L]	0
CODs - Undegradable [mgCOD/L]	0
N - Soluble undegradable organic [mgN/L]	0
Influent inorganic suspended solids [mgISS/L]	0
Precipitate - Struvite [mgISS/L]	0
Precipitate - Brushite [mgISS/L]	0
Precipitate - Hydroxy - apatite [mgISS/L]	0
Precipitate - Vivianite [mgISS/L]	0
HFO - High surface [mg/L]	0
HFO - Low surface [mg/L]	0
HFO - High with H ₂ PO ₄ - adsorbed [mg/L]	0
HFO - Low with H ₂ PO ₄ - adsorbed [mg/L]	0
HFO - Aged [mg/L]	0
HFO - Low with H ⁺ adsorbed [mg/L]	0
HFO - High with H ⁺ adsorbed [mg/L]	0
HAO - High surface [mg/L]	0
HAO - Low surface [mg/L]	0
HAO - High with H ₂ PO ₄ - adsorbed [mg/L]	0
HAO - Low with H ₂ PO ₄ - adsorbed [mg/L]	0
HAO - Aged [mg/L]	0
P - Bound on aged HMO [mgP/L]	0
Metal soluble - Magnesium [mg/L]	0
Metal soluble - Calcium [mg/L]	0
Metal soluble - Ferric [mg/L]	150000,00
Metal soluble - Ferrous [mg/L]	0
Metal soluble - Aluminum [mg/L]	0
Other Cations (strong bases) [meq/L]	5,00
Other Anions (strong acids) [meq/L]	8062,73
Gas - Dissolved total CO ₂ [mmol/L]	7,00
User defined - UD1 [mg/L]	0
User defined - UD2 [mg/L]	0
User defined - UD3 [mgVSS/L]	0



User defined - UD4 [mgSS/L]	0
Biomass - Sulfur oxidizing [mgCOD/L]	0
Biomass - Sulfur reducing propionic acetogenic [mgCOD/L]	0
Biomass - Sulfur reducing acetotrophic [mgCOD/L]	0
Biomass - Sulfur reducing hydrogenotrophic [mgCOD/L]	0
Gas - Dissolved total sulfides [mgS/L]	0
S - Soluble sulfate [mgS/L]	0
S - Particulate elemental sulfur [mgS/L]	0
Precipitate - Ferrous sulfide [mgSS/L]	0
CODp - Adsorbed hydrocarbon [mgCOD/L]	0
CODs - Degradable volatile ind. #1 [mgCOD/L]	0
CODs - Degradable volatile ind. #2 [mgCOD/L]	0
CODs - Degradable volatile ind. #3 [mgCOD/L]	0
CODs - Soluble hydrocarbon [mgCOD/L]	0
Gas - Dissolved oxygen [mg/L]	0
Flow	0,05

Configuration information for all Separator - Dewatering unit units

Operating data Average (flow/time weighted as required)

Element name	Split method	Average Split specification
Grit Compacter	Flow paced	0,01 %
Screening Compacter	Flow paced	0,01 %

Element name	Percent removal
Grit Compacter	100,00
Screening Compacter	100,00

Configuration information for all Separator - Microscreen units

Operating data Average (flow/time weighted as required)



Element name	Split method	Average Split specification
Screen (1mm)	Flow paced	0,02 %

Element name	Percent removal
Screen (1mm)	5,00

Configuration information for all Separator - Cyclone (dewatering) units

Operating data Average (flow/time weighted as required)

Element name	Split method	Average Split specification
Dewatering Centrifuge	Fraction	0,04

Element name	Percent removal
Dewatering Centrifuge	95,00

Configuration information for all Sludge units

Configuration information for all Splitter units

Operating data Average (flow/time weighted as required)

Element name	Split method	Average Split specification
ANA-R1	Flow paced	25,00 %
ANA-R3	Flowrate [Side]	0
ANA-R4	Flowrate [Side]	0
MBR Distribute 1	Fraction	0,67
AS Emergency Bypass	Bypass	7890
INF Distributer 1	Flowrate [Main]	0



INF Distributer 3	Fraction	0,50
Screen Emergency Bypass	Bypass	14640
ANOX-R1	Flow paced	270,00 %
ANOX-R2	Flowrate [Main]	0
ANOX-R4	Fraction	0,50
RAS Splitter 3	Fraction	0,50
WAS Splitter	Flowrate [Side]	25
RAS Splitter 1	Flowrate [Side]	0
SCREENING Splitter	Flowrate [Side]	0
MBR Distribute 2	Fraction	0,50
INF Distributer 2	Fraction	0,50
ANOX-R3	Fraction	0,50
ANA-R2	Flow paced	25,00 %
RAS Splitter 2	Fraction	0,50

Configuration information for all Influent - State variable units

Operating data Average (flow/time weighted as required)

Element name	POLYMER
Biomass - Ordinary heterotrophic [mgCOD/L]	0
Biomass - Methylothetic [mgCOD/L]	0
Biomass - Ammonia oxidizing [mgCOD/L]	0
Biomass - Nitrite oxidizing [mgCOD/L]	0
Biomass - Anaerobic ammonia oxidizing [mgCOD/L]	0
Biomass - Phosphorus accumulating [mgCOD/L]	0
Biomass - Propionic acetogenic [mgCOD/L]	0
Biomass - Acetoclastic methanogenic [mgCOD/L]	0
Biomass - Hydrogenotrophic methanogenic [mgCOD/L]	0
Biomass - Endogenous products [mgCOD/L]	0
CODp - Slowly degradable particulate [mgCOD/L]	18180,00
CODp - Slowly degradable colloidal [mgCOD/L]	0
CODp - Degradable external organics [mgCOD/L]	0
CODp - Undegradable non-cellulose [mgCOD/L]	0
CODp - Undegradable cellulose [mgCOD/L]	0
N - Particulate degradable organic [mgN/L]	0
P - Particulate degradable organic [mgP/L]	0
N - Particulate degradable external organics [mgN/L]	0



P - Particulate degradable external organics [mgP/L]	0
N - Particulate undegradable [mgN/L]	0
P - Particulate undegradable [mgP/L]	0
CODp - Stored PHA [mgCOD/L]	0
P - Releasable stored polyP [mgP/L]	0
P - Unreleasable stored polyP [mgP/L]	0
CODs - Complex readily degradable [mgCOD/L]	0
CODs - Acetate [mgCOD/L]	0
CODs - Propionate [mgCOD/L]	0
CODs - Methanol [mgCOD/L]	0
Gas - Dissolved hydrogen [mgCOD/L]	0
Gas - Dissolved methane [mg/L]	0
N - Ammonia [mgN/L]	0
N - Soluble degradable organic [mgN/L]	0
Gas - Dissolved nitrous oxide [mgN/L]	0
N - Nitrite [mgN/L]	0
N - Nitrate [mgN/L]	0
Gas - Dissolved nitrogen [mgN/L]	0
P - Soluble phosphate [mgP/L]	0
CODs - Undegradable [mgCOD/L]	0
N - Soluble undegradable organic [mgN/L]	0
Influent inorganic suspended solids [mgISS/L]	0
Precipitate - Struvite [mgISS/L]	0
Precipitate - Brushite [mgISS/L]	0
Precipitate - Hydroxy - apatite [mgISS/L]	0
Precipitate - Vivianite [mgISS/L]	0
HFO - High surface [mg/L]	0
HFO - Low surface [mg/L]	0
HFO - High with H ₂ PO ₄ - adsorbed [mg/L]	0
HFO - Low with H ₂ PO ₄ - adsorbed [mg/L]	0
HFO - Aged [mg/L]	0
HFO - Low with H ⁺ adsorbed [mg/L]	0
HFO - High with H ⁺ adsorbed [mg/L]	0
HAO - High surface [mg/L]	0
HAO - Low surface [mg/L]	0
HAO - High with H ₂ PO ₄ - adsorbed [mg/L]	0
HAO - Low with H ₂ PO ₄ - adsorbed [mg/L]	0
HAO - Aged [mg/L]	0
P - Bound on aged HMO [mgP/L]	0
Metal soluble - Magnesium [mg/L]	0
Metal soluble - Calcium [mg/L]	0



Metal soluble - Ferric [mg/L]	0
Metal soluble - Ferrous [mg/L]	0
Metal soluble - Aluminum [mg/L]	0
Other Cations (strong bases) [meq/L]	0
Other Anions (strong acids) [meq/L]	0
Gas - Dissolved total CO2 [mmol/L]	0
User defined - UD1 [mg/L]	0
User defined - UD2 [mg/L]	0
User defined - UD3 [mgVSS/L]	0
User defined - UD4 [mgISS/L]	0
Biomass - Sulfur oxidizing [mgCOD/L]	0
Biomass - Sulfur reducing propionic acetogenic [mgCOD/L]	0
Biomass - Sulfur reducing acetotrophic [mgCOD/L]	0
Biomass - Sulfur reducing hydrogenotrophic [mgCOD/L]	0
Gas - Dissolved total sulfides [mgS/L]	0
S - Soluble sulfate [mgS/L]	0
S - Particulate elemental sulfur [mgS/L]	0
Precipitate - Ferrous sulfide [mgISS/L]	0
CODp - Adsorbed hydrocarbon [mgCOD/L]	0
CODs - Degradable volatile ind. #1 [mgCOD/L]	0
CODs - Degradable volatile ind. #2 [mgCOD/L]	0
CODs - Degradable volatile ind. #3 [mgCOD/L]	0
CODs - Soluble hydrocarbon [mgCOD/L]	0
Gas - Dissolved oxygen [mg/L]	0
Flow	0,65

Configuration information for all Equalization Tank units

Physical data

Element name	Volume[m3]	Area[m2]	Depth[m]
EFF Storage	2150,0000	390,9091	5,500
Drainage	27,0000	9,0000	3,000

BioWin Album



Album page - Loads Overview

Elements	Flow [m3/d]	Total suspended solids [kg /d]	Volatile suspended solids [kg /d]	ISS Total [kg /d]	BOD - Total Carbonaceous [kg /d]	COD - Total [kg /d]	N - Total N [kg N/d]	P - Total P [kg P/d]
INF (including Mugeba)	582,90	213,98	176,26	37,71	206,43	388,97	40,80	5,42
Drainage	0,09	0	0	0	0,01	0,02	0,01	0,00
GRIT	0,03	1,81	0,02	1,80	0,02	0,03	0,00	0,00
SCREENING	0,05	21,64	19,68	1,96	6,48	27,57	0,29	0,10
Dewatering Centrifuge	24,57	6,94	3,65	3,29	2,66	8,92	0,70	1,17
Screen (1mm)	607,40	197,47	160,22	37,25	202,60	370,29	41,21	6,49
ANA-1	449,45	422,53	248,52	174,00	154,40	410,63	35,44	16,42
ANOX-1	1236,36	2595,06	1362,95	1232,11	489,92	1962,04	126,92	111,80
AT-1A	1366,67	3801,13	1936,98	1864,15	637,26	2764,91	171,42	165,64
AT-1B	1366,67	3788,68	1917,77	1870,91	617,23	2734,83	170,13	165,64
Collect Distribute	2733,35	7567,19	3825,58	3741,60	1222,58	5452,56	334,48	331,28
MBR-A	193,76	0	0	0	0,12	5,77	2,01	0,14
EFF Storage	582,45	0	0	0	0,37	17,34	6,03	0,43
EFF	582,45	0,00	0,00	0,00	0,37	17,34	6,03	0,43
RAS Pit	577,07	3167,77	1584,04	1583,73	479,48	2240,41	132,83	140,11
WAS Tank	25,00	130,83	65,11	65,72	18,43	95,48	5,62	6,07
DEWATERED SLUDGE	1,08	131,82	69,34	62,48	22,51	98,38	4,93	4,90
FeCl3	0,05	0	0	0	0	0	0	0
POLYMER	0,65	7,93	7,88	0,05	6,75	11,82	0	0

Album page - Loads

Elements	INF (including Mugeba)	GRIT	SCREENING	EFF	DEWATERED SLUDGE	FeCl3	POLYMER
Flow [m3/d]	582,90	0,03	0,05	582,45	1,08	0,05	0,65
Total suspended solids [kg /d]	213,98	1,81	21,64	0,00	131,82	0	7,93
Volatile suspended solids [kg /d]	176,26	0,02	19,68	0,00	69,34	0	7,88
ISS Total [kg /d]	37,71	1,80	1,96	0,00	62,48	0	0,05
BOD - Total Carbonaceous [kg /d]	206,43	0,02	6,48	0,37	22,51	0	6,75
COD - Total [kg /d]	388,97	0,03	27,57	17,34	98,38	0	11,82



N - Total N [kg N/d]	40,80	0,00	0,29	6,03	4,93	0	0
P - Total P [kg P/d]	5,42	0,00	0,10	0,43	4,90	0	0
Total iron (all forms) [kg Me/d]	0	0,00	0,02	0,00	7,48	7,50	0

Album page - Concentration Overview

Elements	Flow [m3/d]	Total suspended solids [mg/L]	Volatile suspended solids [mg/L]	ISS Total [mg/L]	BOD - Total Carbonaceous [mg/L]	COD - Total [mg/L]	N - Total N [mgN/L]	P - Total P [mgP/L]
INF (including Mugeba)	582,90	367,09	302,39	64,70	354,14	667,30	70,00	9,30
Drainage	0,09	0	0	0	131,98	219,89	64,76	7,16
GRIT	0,03	62244,21	604,69	61639,52	574,19	1112,64	73,90	12,30
SCREENING	0,05	463970,81	421933,41	42037,40	138953,95	591191,84	6278,35	2206,58
Dewatering Centrifuge	24,57	282,35	148,51	133,83	108,39	362,92	28,40	47,72
Screen (1mm)	607,40	325,10	263,78	61,32	333,55	609,63	67,84	10,69
ANA-1	449,45	940,10	552,95	387,15	343,53	913,63	78,86	36,54
ANOX-1	1236,36	2098,95	1102,39	996,56	396,26	1586,94	102,66	90,42
AT-1A	1366,67	2781,30	1417,30	1364,00	466,28	2023,10	125,43	121,20
AT-1B	1366,67	2772,19	1403,24	1368,95	451,63	2001,08	124,48	121,20
Collect Distribute	2733,35	2768,47	1399,60	1368,87	447,28	1994,83	122,37	121,20
MBR-A	193,76	0	0	0	0,63	29,77	10,35	0,74
EFF Storage	582,45	0	0	0	0,63	29,77	10,35	0,74
EFF	582,45	0,00	0,00	0,00	0,63	29,77	10,35	0,74
RAS Pit	577,07	5489,40	2744,96	2744,44	830,89	3882,38	230,18	242,79
WAS Tank	25,00	5233,25	2604,38	2628,88	737,04	3819,37	224,98	242,81
DEWATERED SLUDGE	1,08	122363,23	64362,80	58000,43	20896,38	91324,07	4573,05	4546,11
FeCl3	0,05	0	0	0	0	0	0	0
POLYMER	0,65	12197,85	12120,00	77,85	10383,44	18180,00	0	0

Album page - Concentration

Elements	INF (including Mugeba)	GRIT	Dewatering Centrifuge	SCREENING	ANA-1	ANOX-1	AT-1B	Collect Distribute	EFF	RAS Pit	DEWATERED SLUDGE



Flow [m3/d]	582,90	0,03	24,57	0,05	449,45	1236,36	1366,67	2733,35	582,45	577,07	1,08
Total suspended solids [mg/L]	367,09	62244,21	282,35	463970,81	940,10	2098,95	2772,19	2768,47	0,00	5489,40	122363,23
Volatile suspended solids [mg/L]	302,39	604,69	148,51	421933,41	552,95	1102,39	1403,24	1399,60	0,00	2744,96	64362,80
ISS Total [mg/L]	64,70	61639,52	133,83	42037,40	387,15	996,56	1368,95	1368,87	0,00	2744,44	58000,43
BOD - Total Carbonaceous [mg/L]	354,14	574,19	108,39	138953,95	343,53	396,26	451,63	447,28	0,63	830,89	20896,38
BOD - Filtered Carbonaceous [mg/L]	134,03	134,03	60,31	131,05	65,09	2,36	1,02	0,35	0,63	0,29	60,31
COD - Total [mg/L]	667,30	1112,64	362,92	591191,84	913,63	1586,94	2001,08	1994,83	29,77	3882,38	91324,07
COD - Particulate [mg/L]	445,48	890,83	210,37	590972,82	794,09	1555,63	1971,29	1965,89	0,00	3852,72	91171,53
COD - Filtered [mg/L]	221,82	221,82	152,54	219,01	119,54	31,32	29,79	28,93	29,77	29,67	152,54
N - Total N [mgN/L]	70,00	73,90	28,40	6278,35	78,86	102,66	124,48	122,37	10,35	230,18	4573,05
N - Total Kjeldahl Nitrogen [mgN/L]	69,60	73,50	28,40	6277,97	78,86	102,64	116,46	116,26	1,53	225,00	4573,05
N - Particulate TKN [mgN/L]	3,90	7,80	10,51	6214,20	30,30	83,99	113,97	113,89	0,00	223,44	4555,16
N - Ammonia [mgN/L]	54,80	54,80	16,53	53,25	46,64	17,65	1,09	1,19	0,11	0,31	16,53
N - Nitrate [mgN/L]	0,40	0,40	0,00	0,38	0,00	0,01	6,27	4,57	8,78	5,01	0,00
N - Nitrite [mgN/L]	0	0,00	0,00	0,00	0,00	0,00	1,75	1,54	0,03	0,16	0,00
P - Total P [mgP/L]	9,30	12,30	47,72	2206,58	36,54	90,42	121,20	121,20	0,74	242,79	4546,11
P - Soluble PO4-P [mgP/L]	6,30	6,30	37,32	7,55	5,60	7,76	0,26	0,28	0,74	1,82	37,32



Album page - Conversions

Elements	Nit - Ammonia removal rate [kg/d]	Denit - Nitrate removal rate [kg/d]	OTR [kg/d]	OUR - Carbonaceous [kg/d]	OUR - Nitrification [kg/d]	OUR - Sulfur [kg/d]	OUR - Total [kg/d]	SOTR [kg/d]
ANA-1	0,00	0,12	0	0,00	0,00	0,00	0,00	0
ANA-2	0,00	0,12	0	0,00	0,00	0,00	0,00	0
ANA-3	0	0	0	0	0	0	0	0
ANA-4	0	0	0	0	0	0	0	0
ANOX-1	0,00	3,58	0	0,00	0,00	0,01	0,01	0
ANOX-2	0,00	3,58	0	0,00	0,00	0,01	0,01	0
ANOX-3	0	0	0	0	0	0	0	0
ANOX-4	0	0	0	0	0	0	0	0
AT-1A	8,09	3,08	74,06	30,16	31,02	12,21	73,39	189,27
AT-1B	6,97	1,14	62,75	28,40	29,82	3,16	61,39	177,70
AT-2A	8,09	3,08	74,06	30,16	31,02	12,21	73,39	189,27
AT-2B	6,97	1,14	62,75	28,40	29,82	3,16	61,39	177,70
AT-3A	0	0	0	0	0	0	0	0
AT-3B	0	0	0	0	0	0	0	0
AT-4A	0	0	0	0	0	0	0	0
AT-4B	0	0	0	0	0	0	0	0
Collect Distribute	0,55	4,97	0	1,55	2,12	0,39	4,06	0
MBR-A	1,36	0,10	24,59	14,19	6,28	0,24	20,71	667,64
MBR-B	1,36	0,10	24,58	14,19	6,28	0,24	20,70	651,46
MBR-C	1,36	0,10	24,65	14,23	6,30	0,24	20,77	651,46
RAS Pit	0,75	2,77	0	2,53	3,07	0,16	5,76	0
WAS Tank	0,00	0,13	0	0,00	0,00	0,00	0,00	0
	-----	-----	-----	-----	-----	-----	-----	-----
Total	35,52	24,00	347,44	163,82	145,74	32,03	341,58	2704,50

Global Parameters

Common

Name	Default	Value
Hydrolysis rate [1/d]	2,1000	2,1000 1,0290
Hydrolysis half sat. [-]	0,0600	0,0600 1,0000
Anoxic hydrolysis factor [-]	0,2800	0,2800 1,0000



Anaerobic hydrolysis factor (AS) [-]	0,0400	0,0400	1,0000
Anaerobic hydrolysis factor (AD) [-]	0,5000	0,5000	1,0000
Adsorption rate of colloids [L/(mgCOD d)]	0,1500	0,1500	1,0290
Ammonification rate [L/(mgCOD d)]	0,0800	0,0800	1,0290
Assimilative nitrate/nitrite reduction rate [1/d]	0,5000	0,5000	1,0000
Endogenous products decay rate [1/d]	0	0	1,0000

Ammonia oxidizing

Name	Default	Value	
Max. spec. growth rate [1/d]	0,9000	0,9000	1,0720
Substrate (NH4) half sat. [mgN/L]	0,7000	0,7000	1,0000
Byproduct NH4 logistic slope [-]	50,0000	50,0000	1,0000
Byproduct NH4 inflection point [mgN/L]	1,4000	1,4000	1,0000
Denite DO half sat. [mg/L]	0,1000	0,1000	1,0000
Denite HNO2 half sat. [mgN/L]	5,000E-6	5,000E-6	1,0000
Aerobic decay rate [1/d]	0,1700	0,1700	1,0290
Anoxic/anaerobic decay rate [1/d]	0,0800	0,0800	1,0290
KiHNO2 [mmol/L]	5,000E-3	5,000E-3	1,0000

Nitrite oxidizing

Name	Default	Value	
Max. spec. growth rate [1/d]	0,7000	0,7000	1,0600
Substrate (NO2) half sat. [mgN/L]	0,1000	0,1000	1,0000
Aerobic decay rate [1/d]	0,1700	0,1700	1,0290
Anoxic/anaerobic decay rate [1/d]	0,0800	0,0800	1,0290
KiNH3 [mmol/L]	0,0750	0,0750	1,0000

Anaerobic ammonia oxidizing

Name	Default	Value	
Max. spec. growth rate [1/d]	0,2000	0,2000	1,1000
Substrate (NH4) half sat. [mgN/L]	2,0000	2,0000	1,0000



Substrate (NO2) half sat. [mgN/L]	1,0000	1,0000	1,0000
Aerobic decay rate [1/d]	0,0190	0,0190	1,0290
Anoxic/anaerobic decay rate [1/d]	9,500E-3	9,500E-3	1,0290
Ki Nitrite [mgN/L]	1000,0000	1000,0000	1,0000
Nitrite sensitivity constant [L / (d mgN)]	0,0160	0,0160	1,0000

Ordinary heterotrophic

Name	Default	Value	
Max. spec. growth rate [1/d]	3,2000	3,2000	1,0290
Substrate half sat. [mgCOD/L]	5,0000	5,0000	1,0000
Anoxic growth factor [-]	0,5000	0,8000	1,0000
Denite N2 producers (NO3 or NO2) [-]	0,5000	0,5000	1,0000
Aerobic decay rate [1/d]	0,6200	0,6200	1,0290
Anoxic decay rate [1/d]	0,2330	0,2330	1,0290
Anaerobic decay rate [1/d]	0,1310	0,1310	1,0290
Fermentation rate [1/d]	1,6000	1,6000	1,0290
Fermentation half sat. [mgCOD/L]	5,0000	5,0000	1,0000
Fermentation growth factor (AS) [-]	0,2500	0,2500	1,0000
Free nitrous acid inhibition [mol/L]	1,000E-7	1,000E-7	1,0000

Heterotrophic on industrial COD

Name	Default	Value	
Maximum specific growth rate on Ind #1 COD [1/d]	4,3000	4,3000	1,0290
Substrate (Ind #1) half sat. [mgCOD/L]	1,0000	1,0000	1,0000
Inhibition coefficient for Ind #1 [mgCOD/L]	60,0000	60,0000	1,0000
Anaerobic growth factor for Ind #1 [mgCOD/L]	0,0500	0,0500	1,0000
Maximum specific growth rate on Ind #2 COD [1/d]	1,5000	1,5000	1,0290
Substrate (Ind #2) half sat. [mgCOD/L]	30,0000	30,0000	1,0000
Inhibition coefficient for Ind #2 [mgCOD/L]	3000,0000	3000,0000	1,0000
Anaerobic growth factor for Ind #2 [mgCOD/L]	0,0500	0,0500	1,0000
Maximum specific growth rate on Ind #3 COD [1/d]	4,3000	4,3000	1,0290
Substrate (Ind #3) half sat. [mgCOD/L]	1,0000	1,0000	1,0000
Inhibition coefficient for Ind #3 COD [mgCOD/L]	60,0000	60,0000	1,0000
Anaerobic growth factor for Ind #3 [mgCOD/L]	0,0500	0,0500	1,0000



Maximum specific growth rate on adsorbed hydrocarbon COD [1/d]	2,0000	2,0000	1,0290
Substrate (adsorbed hydrocarbon) half sat. [-]	0,1500	0,1500	1,0000
Anaerobic growth factor for adsorbed hydrocarbons [mgCOD/L]	0,0100	0,0100	1,0000
Adsorption rate of soluble hydrocarbons [l/(mgCOD d)]	0,2000	0,2000	1,0000

Methylotrophic

Name	Default	Value	
Max. spec. growth rate [1/d]	1,3000	1,3000	1,0720
Methanol half sat. [mgCOD/L]	0,5000	0,5000	1,0000
Denite N2 producers (NO3 or NO2) [-]	0,5000	0,5000	1,0000
Aerobic decay rate [1/d]	0,0400	0,0400	1,0290
Anoxic/anaerobic decay rate [1/d]	0,0300	0,0300	1,0290
Free nitrous acid inhibition [mmol/L]	1,000E-7	1,000E-7	1,0000

Phosphorus accumulating

Name	Default	Value	
Max. spec. growth rate [1/d]	0,9500	0,9500	1,0000
Max. spec. growth rate, P-limited [1/d]	0,4200	0,4200	1,0000
Substrate half sat. [mgCOD(PHB)/mgCOD(Zbp)]	0,1000	0,1000	1,0000
Substrate half sat., P-limited [mgCOD(PHB)/mgCOD(Zbp)]	0,0500	0,0500	1,0000
Magnesium half sat. [mgMg/L]	0,1000	0,1000	1,0000
Cation half sat. [mmol/L]	0,1000	0,1000	1,0000
Calcium half sat. [mgCa/L]	0,1000	0,1000	1,0000
Aerobic/anoxic decay rate [1/d]	0,1000	0,1000	1,0000
Aerobic/anoxic maintenance rate [1/d]	0	0	1,0000
Anaerobic decay rate [1/d]	0,0400	0,0400	1,0000
Anaerobic maintenance rate [1/d]	0	0	1,0000
Sequestration rate [1/d]	4,5000	4,5000	1,0000
Anoxic growth factor [-]	0,3300	0,3300	1,0000

Propionic acetogenic



Name	Default	Value	
Max. spec. growth rate [1/d]	0,2500	0,2500	1,0290
Substrate half sat. [mgCOD/L]	10,0000	10,0000	1,0000
Acetate inhibition [mgCOD/L]	10000,0000	10000,0000	1,0000
Anaerobic decay rate [1/d]	0,0500	0,0500	1,0290
Aerobic/anoxic decay rate [1/d]	0,5200	0,5200	1,0290

Methanogenic

Name	Default	Value	
Acetoclastic max. spec. growth rate [1/d]	0,3000	0,3000	1,0290
H2-utilizing max. spec. growth rate [1/d]	1,4000	1,4000	1,0290
Acetoclastic substrate half sat. [mgCOD/L]	100,0000	100,0000	1,0000
Acetoclastic methanol half sat. [mgCOD/L]	0,5000	0,5000	1,0000
H2-utilizing CO2 half sat. [mmol/L]	0,1000	0,1000	1,0000
H2-utilizing substrate half sat. [mgCOD/L]	1,0000	1,0000	1,0000
H2-utilizing methanol half sat. [mgCOD/L]	0,5000	0,5000	1,0000
Acetoclastic propionic inhibition [mgCOD/L]	10000,0000	10000,0000	1,0000
Acetoclastic anaerobic decay rate [1/d]	0,1300	0,1300	1,0290
Acetoclastic aerobic/anoxic decay rate [1/d]	0,6000	0,6000	1,0290
H2-utilizing anaerobic decay rate [1/d]	0,1300	0,1300	1,0290
H2-utilizing aerobic/anoxic decay rate [1/d]	2,8000	2,8000	1,0290

Sulfur oxidizing

Name	Default	Value	
Maximum specific growth rate (sulfide) [1/d]	0,7500	0,7500	1,0290
Maximum specific growth rate (sulfur) [1/d]	0,1000	0,1000	1,0290
Substrate (H2S) half sat. [mgS/L]	1,0000	1,0000	1,0000
Substrate (sulfur) half sat. [mgS/L]	1,0000	1,0000	1,0000
Anoxic growth factor [-]	0,5000	0,5000	1,0000
Decay rate [1/d]	0,0400	0,0400	1,0290

Sulfur reducing



Name	Default	Value	
Propionic max. spec. growth rate [1/d]	0,5830	0,5830	1,0350
Propionic acid half sat. [mgCOD/L]	295,0000	295,0000	1,0000
Hydrogen sulfide inhibition coefficient [mgS/L]	185,0000	185,0000	1,0000
Sulfate (SO4=) half sat. [mgS/L]	2,4700	2,4700	1,0000
Decay rate [1/d]	0,0185	0,0185	1,0350
Acetotrophic max. spec. growth rate [1/d]	0,6120	0,6120	1,0350
Acetic acid half sat. [mgCOD/L]	24,0000	24,0000	1,0000
Hydrogen sulfide inhibition coefficient [mgS/L]	164,0000	164,0000	1,0000
Sulfate (SO4=) half sat. [mgS/L]	6,4100	6,4100	1,0000
Decay rate [1/d]	0,0275	0,0275	1,0350
Hydrogenotrophic max. spec. growth rate with SO4= [1/d]	2,8000	2,8000	1,0350
Hydrogenotrophic max. spec. growth rate with S [1/d]	0,1000	0,1000	1,0350
Hydrogen half sat. [mgCOD/L]	0,0700	0,0700	1,0000
Hydrogen sulfide inhibition coefficient [mgS/L]	550,0000	550,0000	1,0000
Sulfate (SO4=) half sat. [mgS/L]	6,4100	6,4100	1,0000
Sulfur (S) half sat. [mgS/L]	50,0000	50,0000	1,0000
Decay rate [1/d]	0,0600	0,0600	1,0350

pH

Name	Default	Value
Ordinary heterotrophic low pH limit [-]	4,0000	4,0000
Ordinary heterotrophic high pH limit [-]	10,0000	10,0000
Methylotrophic low pH limit [-]	4,0000	4,0000
Methylotrophic high pH limit [-]	10,0000	10,0000
Autotrophic low pH limit [-]	5,5000	5,5000
Autotrophic high pH limit [-]	9,5000	9,5000
Phosphorus accumulating low pH limit [-]	4,0000	4,0000
Phosphorus accumulating high pH limit [-]	10,0000	10,0000
Ordinary heterotrophic low pH limit (anaerobic) [-]	5,5000	5,5000
Ordinary heterotrophic high pH limit (anaerobic) [-]	8,5000	8,5000
Propionic acetogenic low pH limit [-]	4,0000	4,0000
Propionic acetogenic high pH limit [-]	10,0000	10,0000
Acetoclastic methanogenic low pH limit [-]	5,0000	5,0000
Acetoclastic methanogenic high pH limit [-]	9,0000	9,0000
H2-utilizing methanogenic low pH limit [-]	5,0000	5,0000
H2-utilizing methanogenic high pH limit [-]	9,0000	9,0000



Switches

Name	Default	Value
Ordinary heterotrophic DO half sat. [mgO ₂ /L]	0,1500	0,1500
Phosphorus accumulating DO half sat. [mgO ₂ /L]	0,0500	0,0500
Anoxic/anaerobic NO _x half sat. [mgN/L]	0,1500	0,1500
Ammonia oxidizing DO half sat. [mgO ₂ /L]	0,2500	0,2500
Nitrite oxidizing DO half sat. [mgO ₂ /L]	0,5000	0,5000
Anaerobic ammonia oxidizing DO half sat. [mgO ₂ /L]	0,0100	0,0100
Sulfur oxidizing sulfate pathway DO half sat. [mgO ₂ /L]	0,2500	0,2500
Sulfur oxidizing sulfur pathway DO half sat. [mgO ₂ /L]	0,0500	0,0500
Anoxic NO ₃ (->NO ₂) half sat. [mgN/L]	0,1000	0,1000
Anoxic NO ₃ (->N ₂) half sat. [mgN/L]	0,0500	0,0500
Anoxic NO ₂ (->N ₂) half sat. (mgN/L)	0,0100	0,0100
NH ₃ nutrient half sat. [mgN/L]	5,000E-3	5,000E-3
PolyP half sat. [mgP/mgCOD]	0,0100	0,0100
VFA sequestration half sat. [mgCOD/L]	5,0000	5,0000
P uptake half sat. [mgP/L]	0,1500	0,1500
P nutrient half sat. [mgP/L]	1,000E-3	1,000E-3
Autotrophic CO ₂ half sat. [mmol/L]	0,1000	0,1000
H ₂ low/high half sat. [mgCOD/L]	1,0000	1,0000
Propionic acetogenic H ₂ inhibition [mgCOD/L]	5,0000	5,0000
Synthesis anion/cation half sat. [meq/L]	0,0100	0,0100

Common

Name	Default	Value
Biomass/Endog Ca content (gCa/gCOD)	3,912E-3	3,912E-3
Biomass/Endog Mg content (gMg/gCOD)	3,912E-3	3,912E-3
Biomass/Endog other cations content (mol/gCOD)	5,115E-4	5,115E-4
Biomass/Endog other Anions content (mol/gCOD)	1,410E-4	1,410E-4
N in endogenous residue [mgN/mgCOD]	0,0700	0,0700
P in endogenous residue [mgP/mgCOD]	0,0220	0,0220
Ca content of slowly biodegradable (gCa/gCOD)	3,912E-3	3,912E-3
Mg content of slowly biodegradable (gMg/gCOD)	3,700E-4	3,700E-4
Endogenous residue COD:VSS ratio [mgCOD/mgVSS]	1,4200	1,4200
Particulate substrate COD:VSS ratio [mgCOD/mgVSS]	1,6327	1,5000

Particulate inert COD:VSS ratio [mgCOD/mgVSS]	1,6000	1,1000
Cellulose COD:VSS ratio [mgCOD/mgVSS]	1,4000	1,4000
External organic COD:VSS ratio [mgCOD/mgVSS]	1,6000	1,6000
Molecular weight of other anions [mg/mmol]	35,5000	35,5000
Molecular weight of other cations [mg/mmol]	39,0983	39,0983

Ammonia oxidizing

Name	Default	Value
Yield [mgCOD/mgN]	0,1500	0,1500
Denite NO2 fraction as TEA [-]	0,5000	0,5000
Byproduct NH4 fraction to N2O [-]	2,500E-3	2,500E-3
N in biomass [mgN/mgCOD]	0,0700	0,0700
P in biomass [mgP/mgCOD]	0,0220	0,0220
Fraction to endogenous residue [-]	0,0800	0,0800
COD:VSS ratio [mgCOD/mgVSS]	1,4200	1,4200

Nitrite oxidizing

Name	Default	Value
Yield [mgCOD/mgN]	0,0900	0,0900
N in biomass [mgN/mgCOD]	0,0700	0,0700
P in biomass [mgP/mgCOD]	0,0220	0,0220
Fraction to endogenous residue [-]	0,0800	0,0800
COD:VSS ratio [mgCOD/mgVSS]	1,4200	1,4200

Anaerobic ammonia oxidizing

Name	Default	Value
Yield [mgCOD/mgN]	0,1140	0,1140
Nitrate production [mgN/mgBiomassCOD]	2,2800	2,2800
N in biomass [mgN/mgCOD]	0,0700	0,0700
P in biomass [mgP/mgCOD]	0,0220	0,0220
Fraction to endogenous residue [-]	0,0800	0,0800



COD:VSS ratio [mgCOD/mgVSS]	1,4200	1,4200
-----------------------------	--------	--------

Ordinary heterotrophic

Name	Default	Value
Yield (aerobic) [-]	0,6660	0,6660
Yield (fermentation, low H2) [-]	0,1000	0,1000
Yield (fermentation, high H2) [-]	0,1000	0,1000
H2 yield (fermentation low H2) [-]	0,3500	0,3500
H2 yield (fermentation high H2) [-]	0	0
Propionate yield (fermentation, low H2) [-]	0	0
Propionate yield (fermentation, high H2) [-]	0,7000	0,7000
CO2 yield (fermentation, low H2) [-]	0,7000	0,7000
CO2 yield (fermentation, high H2) [-]	0	0
N in biomass [mgN/mgCOD]	0,0700	0,0700
P in biomass [mgP/mgCOD]	0,0220	0,0220
Endogenous fraction - aerobic [-]	0,0800	0,0800
Endogenous fraction - anoxic [-]	0,1030	0,1030
Endogenous fraction - anaerobic [-]	0,1840	0,1840
COD:VSS ratio [mgCOD/mgVSS]	1,4200	1,4200
Yield (anoxic) [-]	0,5400	0,5400
Yield propionic (aerobic) [-]	0,6400	0,6400
Yield propionic (anoxic) [-]	0,4600	0,4600
Yield acetic (aerobic) [-]	0,6000	0,6000
Yield acetic (anoxic) [-]	0,4300	0,4300
Yield methanol (aerobic) [-]	0,5000	0,5000
Adsorp. max. [-]	1,0000	1,0000
Max fraction to N2O at high FNA over nitrate [-]	0,0500	0,0500
Max fraction to N2O at high FNA over nitrite [-]	0,1000	0,1000

Ordinary heterotrophic on industrial COD

Name	Default	Value
Yield Ind #1 COD (Aerobic) [-]	0,5000	0,5000
Yield Ind #1 COD (Anoxic) [-]	0,4000	0,4000
Yield Ind #1 COD (Anaerobic) [-]	0,0400	0,0400

COD:Mole ratio - Ind #1 COD [gCOD/Mol]	224,0000	224,0000
Yield Ind #2 COD (Aerobic) [-]	0,5000	0,5000
Yield Ind #2 COD (Anoxic) [-]	0,4000	0,4000
Yield Ind #2 COD (Anaerobic) [-]	0,0500	0,0500
COD:Mole ratio - Ind #2 COD [gCOD/Mol]	240,0000	240,0000
Yield on Ind #3 COD (Aerobic) [-]	0,5000	0,5000
Yield on Ind #3 COD (Anoxic) [-]	0,4000	0,4000
Yield on Ind #3 COD (Anaerobic) [-]	0,0400	0,0400
COD:Mole ratio - Ind #3 COD [gCOD/Mol]	288,0000	288,0000
Yield enmeshed hydrocarbons (Aerobic) [-]	0,5000	0,5000
Yield enmeshed hydrocarbons (Anoxic) [-]	0,4000	0,4000
Yield enmeshed hydrocarbons (Anaerobic) [-]	0,0400	0,0400
COD:Mole ratio - Hydrocarbon COD [gCOD/Mol]	336,0000	336,0000
Hydrocarbon COD:VSS ratio [mgCOD/mgVSS]	3,2000	3,2000
Max. hydrocarbon adsorp. ratio [-]	1,0000	1,0000
Yield of Ind #1 on Ind #3 COD (Aerobic) [-]	0	0
Yield of Ind #1 on Ind #3 COD (Anoxic) [-]	0	0
Hydrocarbon Yield on Ind #3 COD (Aerobic) [-]	0	0
Hydrocarbon Yield on Ind #3 COD (Anoxic) [-]	0	0

Methylotrophic

Name	Default	Value
Yield (anoxic) [-]	0,4000	0,4000
N in biomass [mgN/mgCOD]	0,0700	0,0700
P in biomass [mgP/mgCOD]	0,0220	0,0220
Fraction to endogenous residue [-]	0,0800	0,0800
COD:VSS ratio [mgCOD/mgVSS]	1,4200	1,4200
Max fraction to N ₂ O at high FNA over nitrate [-]	0,1000	0,1000
Max fraction to N ₂ O at high FNA over nitrite [-]	0,1500	0,1500

Phosphorus accumulating

Name	Default	Value
Yield (aerobic) [-]	0,6390	0,6390
Yield (anoxic) [-]	0,5200	0,5200

Aerobic P/PHA uptake [mgP/mgCOD]	0,9300	0,9300
Anoxic P/PHA uptake [mgP/mgCOD]	0,3500	0,3500
Yield of PHA on sequestration [-]	0,8890	0,8890
N in biomass [mgN/mgCOD]	0,0700	0,0700
N in sol. inert [mgN/mgCOD]	0,0700	0,0700
P in biomass [mgP/mgCOD]	0,0220	0,0220
Fraction to endogenous part. [-]	0,2500	0,2500
Inert fraction of endogenous sol. [-]	0,2000	0,2000
P/Ac release ratio [mgP/mgCOD]	0,5100	0,5100
COD:VSS ratio [mgCOD/mgVSS]	1,4200	1,4200
Yield of low PP [-]	0,9400	0,9400
Mg to P mole ratio in polyphosphate [mmolMg/mmolP]	0,3000	0,3000
Cation to P mole ratio in polyphosphate [meq/mmolP]	0,1500	0,1500
Ca to P mole ratio in polyphosphate [mmolCa/mmolP]	0,0500	0,0500

Propionic acetogenic

Name	Default	Value
Yield [-]	0,1000	0,1000
H2 yield [-]	0,4000	0,4000
CO2 yield [-]	1,0000	1,0000
N in biomass [mgN/mgCOD]	0,0700	0,0700
P in biomass [mgP/mgCOD]	0,0220	0,0220
Fraction to endogenous residue [-]	0,0800	0,0800
COD:VSS ratio [mgCOD/mgVSS]	1,4200	1,4200

Methanogenic

Name	Default	Value
Acetoclastic yield [-]	0,1000	0,1000
Acetoclastic yield on methanol[-]	0,1000	0,1000
H2-utilizing yield [-]	0,1000	0,1000
H2-utilizing yield on methanol [-]	0,1000	0,1000
N in acetoclastic biomass [mgN/mgCOD]	0,0700	0,0700
N in H2-utilizing biomass [mgN/mgCOD]	0,0700	0,0700
P in acetoclastic biomass [mgP/mgCOD]	0,0220	0,0220



P in H2-utilizing biomass [mgP/mgCOD]	0,0220	0,0220
Acetoclastic fraction to endog. residue [-]	0,0800	0,0800
H2-utilizing fraction to endog. residue [-]	0,0800	0,0800
Acetoclastic COD:VSS ratio [mgCOD/mgVSS]	1,4200	1,4200
H2-utilizing COD:VSS ratio [mgCOD/mgVSS]	1,4200	1,4200

Sulfur oxidizing

Name	Default	Value
Yield (aerobic) [mgCOD/mgS]	0,5000	0,5000
Yield (Anoxic) [mgCOD/mgS]	0,3500	0,3500
N in biomass [mgN/mgCOD]	0,0700	0,0700
P in biomass [mgP/mgCOD]	0,0220	0,0220
Fraction to endogenous residue [-]	0,0800	0,0800
COD:VSS ratio [mgCOD/mgVSS]	1,4200	1,4200

Sulfur reducing

Name	Default	Value
Yield [mgCOD/mg H2 COD]	0,0712	0,0712
Yield [mgCOD/mg Ac COD]	0,0470	0,0470
Yield [mgCOD/mg Pr COD]	0,0384	0,0384
N in biomass [mgN/mgCOD]	0,0700	0,0700
P in biomass [mgP/mgCOD]	0,0220	0,0220
Fraction to endogenous residue [-]	0,0800	0,0800
COD:VSS ratio [mgCOD/mgVSS]	1,4200	1,4200

General

Name	Default	Value
Tank head loss per metre of length (from flow) [m/m]	2,500E-3	2,500E-3
BOD calculation rate constant for Xsc degradation [1/d]	0,5000	0,5000
BOD calculation rate constant for Xsp (and hydrocarbon) degradation [1/d]	0,5000	0,5000
BOD calculation rate constant for Xeo degradation [1/d]	0,5000	0,5000



Heating fuel/Chemical Costs

Name	Default	Value
Methanol [€/L]	0,3884	0,3884
Ferric [€/L]	0,0883	0,0883
Ferrous [€/L]	0,0883	0,0883
Aluminium [€/L]	0,0706	0,0706
Natural gas [€/GJ]	2,6480	2,6480
Heating oil [€/L]	0,4413	0,4413
Diesel [€/L]	0,6179	0,6179
Custom fuel [€/L]	0,8827	0,8827
Biogas sale price [€/GJ]	1,7653	1,7653

Anaerobic digester

Name	Default	Value
Bubble rise velocity (anaerobic digester) [cm/s]	23,9000	23,9000
Bubble Sauter mean diameter (anaerobic digester) [cm]	0,3500	0,3500
Anaerobic digester gas hold-up factor []	1,0000	1,0000

Combined Heat and Power (CHP) engine

Name	Default	Value
Methane heat of combustion [kJ/mole]	800,0000	800,0000
Hydrogen heat of combustion [kJ/mole]	240,0000	240,0000
CHP engine heat price [€/kWh]	0	0
CHP engine power price [€/kWh]	0,1324	0,1324

Calorific values of heating fuels

Name	Default	Value
------	---------	-------



Calorific value of natural gas [kJ/kg]	48000	48000
Calorific value of heating fuel oil [kJ/kg]	42000	42000
Calorific value of diesel [kJ/kg]	46000	46000
Calorific value of custom fuel [kJ/kg]	32000	32000

Density of liquid heating fuels

Name	Default	Value
Density of heating fuel oil [kg/m3]	900	900
Density of diesel [kg/m3]	875	875
Density of custom fuel [kg/m3]	790	790

Mass transfer

Name	Default	Value
KI for H2 [m/d]	17,0000	17,0000 1,0240
KI for CO2 [m/d]	10,0000	10,0000 1,0240
KI for NH3 [m/d]	1,0000	1,0000 1,0240
KI for CH4 [m/d]	8,0000	8,0000 1,0240
KI for N2 [m/d]	15,0000	15,0000 1,0240
KI for N2O [m/d]	8,0000	8,0000 1,0240
KI for H2S [m/d]	1,0000	1,0000 1,0240
KI for Ind #1 COD [m/d]	0	0 1,0240
KI for Ind #2 COD [m/d]	0,5000	0,5000 1,0240
KI for Ind #3 COD [m/d]	0	0 1,0240
KI for O2 [m/d]	13,0000	13,0000 1,0240

Henry's law constants

Name	Default	Value
CO2 [M/atm]	3,4000E-2	3,4000E-2 2400,0000
O2 [M/atm]	1,3000E-3	1,3000E-3 1500,0000
N2 [M/atm]	6,5000E-4	6,5000E-4 1300,0000
N2O [M/atm]	2,5000E-2	2,5000E-2 2600,0000



NH3 [M/atm]	5,8000E+1	5,8000E+1	4100,0000
CH4 [M/atm]	1,4000E-3	1,4000E-3	1600,0000
H2 [M/atm]	7,8000E-4	7,8000E-4	500,0000
H2S [M/Atm]	1,0000E-1	1,0000E-1	2200,0000
Ind 1 [M/Atm]	1,9000E+3	1,9000E+3	7300,0000
Ind 2 [M/Atm]	1,8000E-1	1,8000E-1	2200,0000
Ind 3 [M/Atm]	1,5000E-1	1,5000E-1	1900,0000

Properties constants

Name	Default	Value
K in Viscosity = $K e^{-(Ea/RT)}$ [Pa s]	6,849E-7	6,849E-7
Ea in Viscosity = $K e^{-(Ea/RT)}$ [J/mol]	1,780E+4	1,780E+4
Y in ML Viscosity = H2O viscosity * (1+A*MLSS^Y) [-]	1,0000	1,0000
A in ML Viscosity = H2O viscosity * (1+A*MLSS^Y) [m3/g]	1,000E-7	1,000E-7
A in ML Density = H2O density + A*MLSS [(kg/m3)/(g/m3)]	3,248E-4	3,248E-4
A in Antoine equn. [T in K, P in Bar {NIST}]	5,2000	5,2000
B in Antoine equn. [T in K, P in Bar {NIST}]	1734,0000	1734,0000
C in Antoine equn. [T in K, P in Bar {NIST}]	-39,5000	-39,5000

Metal salt solution densities

Name	Default	Value
Ferric chloride solution density [kg/m3]	3820,0000	3820,0000
Ferrous chloride solution density [kg/m3]	3160,0000	3160,0000
Aluminium sulfate solution density [kg/m3]	1950,0000	1950,0000

Mineral precipitation rates

Name	Default	Value	
Vivianite precipitation rate [L/(mol d)]	1,000E+5	1,000E+5	1,0240
Vivianite redissolution rate [L/(mol d)]	1,000E+5	1,000E+5	1,0240
Vivianite half sat. [mgTSS/L]	0,0100	0,0100	1,0000
FeS precipitation rate [L/(mol d)]	1000,0000	1000,0000	1,0240



FeS redissolution rate [L/(mol d)]	10,0000	10,0000	1,0240
FeS half sat. [mgTSS/L]	0,1000	0,1000	1,0000
Struvite precipitation rate [L ² /(mol ² d)]	3,000E+10	3,000E+10	1,0240
Struvite redissolution rate [L ² /(mol ² d)]	3,000E+11	3,000E+11	1,0240
Struvite half sat. [mgTSS/L]	1,0000	1,0000	1,0000
Brushite precipitation rate [L/(mol d)]	1,000E+6	1,000E+6	1,0000
Brushite redissolution rate [L/(mol d)]	10000,0000	10000,0000	1,0000
Brushite half sat. [mgTSS/L]	1,0000	1,0000	1,0000
HAP precipitation rate [g/d]	5,000E-4	5,000E-4	1,0000

Mineral precipitation constants

Name	Default	Value
Vivianite solubility product [mol/L] ⁵	1,710E-36	1,710E-36
FeS solubility product [mol/L] ²	4,258E-4	4,258E-4
Struvite solubility product [mol/L] ³	6,918E-14	6,918E-14
Brushite solubility product [mol/L] ²	2,490E-7	2,490E-7

Fe rates

Name	Default	Value	
A in aging rate = $A \cdot \exp(-G/B)$ [1/d]	16,1550	16,1550	1,0000
B in aging rate = $A \cdot \exp(-G/B)$ [1/s]	57,3000	57,3000	1,0000
HFO(L) aging rate factor	2,500E-4	2,500E-4	1,0000
HFO(H) with H ₂ PO ₄ ⁻ bound aging factor []	1,000E-5	1,000E-5	1,0000
HFO(L) with H ₂ PO ₄ ⁻ bound aging factor []	0,4000	0,4000	1,0000
H ₂ PO ₄ ⁻ coprecipitation rate [mol/(L d)]	1,500E-9	1,500E-9	1,0000
H ₂ PO ₄ ⁻ Adsorption rate [mol/(L d)]	2,000E-11	2,000E-11	1,0000
H ⁺ competition for HFO(H) protonation sites [L/(mmol . d)]	1000,0000	1000,0000	1,0000
H ⁺ competition for HFO(L) protonation sites [L/(mmol . d)]	100,0000	100,0000	1,0000

Fe constants

Name	Default	Value
------	---------	-------



Ferric active site factor(high) [{mol Sites}/{mol HFO(H)}]	4,0000	4,0000
Ferric active site factor(low) [{mol Sites}/{mol HFO(L)}]	2,4000	2,4000
H+ competition level for Fe(OH)3 [mol/L]	7,000E-7	7,000E-7
Equilibrium constant for FeOH3-H2PO4- [{mf HFO(H).H2PO4-}/({mol H2PO4-}{mf HFO(H)}^2)]	2,000E-9	2,000E-9
Colloidal COD removed with Ferric [gCOD/Fe active site]	80,0000	80,0000
Minimum residual P level with iron addition [mgP/L]	0,0150	0,0150
HFO(H) with H2PO4- P release factor	10000,0000	10000,0000
HFO(L) with H2PO4- P release factor	10000,0000	10000,0000

Fe RedOx rates

Name	Default	Value	
Iron reduction using acetic acid	1,000E-7	1,000E-7	1,0000
Half Sat. acetic acid	0,5000	0,5000	1,0000
Iron reduction using propionic acid	1,000E-7	1,000E-7	1,0000
Half Sat. propionic acid	0,5000	0,5000	1,0000
Iron reduction using dissolved hydrogen gas	1,000E-7	1,000E-7	1,0000
Half Sat. dissolved hydrogen gas	0,5000	0,5000	1,0000
Iron reduction using hydrogen sulfide	5,000E-5	5,000E-5	1,0000
Half Sat. hydrogen sulfide	0,5000	0,5000	1,0000
Iron oxidation rate (aerobic)	1,000E-3	1,000E-3	1,0000
Abiotic iron reduction using acetic acid	2,000E-5	2,000E-5	1,0000
Abiotic iron reduction using propionic acid	2,000E-5	2,000E-5	1,0000
Abiotic iron reduction using dissolved hydrogen gas	2,000E-5	2,000E-5	1,0000
Abiotic iron reduction using hydrogen sulfide	2,000E-5	2,000E-5	1,0000
Abiotic iron oxidation rate (aerobic)	1,0000	1,0000	1,0000

CEPT rates

Name	Default	Value	
HFO colloidal adsorption rate	1,0000	1,0000	1,0000
Residual Xsc for adsorption to HFO	5,0000	5,0000	1,0000
Slope for Xsc residual	1,0000	1,0000	1,0000
HAO colloidal adsorption rate	1,0000	1,0000	1,0000
Residual Xsc for adsorption to HAO	5,0000	5,0000	1,0000
Slope for Xsc residual	1,0000	1,0000	1,0000

Al rates

Name	Default	Value	
A in aging rate = $A * \exp(-G/B)$ [1/d]	16,1550	16,1550	1,0000
B in aging rate = $A * \exp(-G/B)$ [1/s]	57,3000	57,3000	1,0000
HAO(L) aging rate factor	2,500E-4	2,500E-4	1,0000
HAO(H) with H ₂ PO ₄ ⁻ bound aging factor []	1,000E-5	1,000E-5	1,0000
HAO(L) with H ₂ PO ₄ ⁻ bound aging factor []	0,4000	0,4000	1,0000
H ₂ PO ₄ ⁻ coprecipitation rate [mol/(L d)]	1,500E-9	1,500E-9	1,0000
H ₂ PO ₄ ⁻ Adsorption rate [mol/(L d)]	1,000E-9	1,000E-9	1,0000

Al constants

Name	Default	Value
Al active site factor(high) [$\frac{\text{mol Sites}}{\text{mol HAO(H)}}$]	3,0000	3,0000
Al active site factor(low) [$\frac{\text{mol Sites}}{\text{mol HAO(L)}}$]	1,5000	1,5000
Equilibrium constant for AlOH ₃ -H ₂ PO ₄ ⁻ [$\frac{\text{mf HAO(H)} \cdot \text{H}_2\text{PO}_4^-}{\text{(mol H}_2\text{PO}_4^-) \cdot \text{(mf HAO(H))^2}}$]	8,000E-10	8,000E-10
Colloidal COD removed with Al [gCOD/Al active site]	30,0000	30,0000
Minimum residual P level with Al addition [mgP/L]	0,0150	0,0150
HAO(H) with H ₂ PO ₄ ⁻ P release factor	10000,0000	10000,0000
HAO(L) with H ₂ PO ₄ ⁻ P release factor	10000,0000	10000,0000

Pipe and pump parameters

Name	Default	Value
Static head [m]	0,2500	0,2500
Pipe length (headloss calc.s) [m]	50,0000	50,0000
Pipe inside diameter [mm]	500,000	500,000
K(fittings) - Total minor losses K	5,0000	5,0000
Pipe roughness [mm]	0,200	0,200
'A' in overall pump efficiency = $A + B \cdot Q + C \cdot (Q^2)$ [-]	0,8500	0,8500
'B' in overall pump efficiency = $A + B \cdot Q + C \cdot (Q^2)$ [-]/(m ³ /d)]	0	0
'C' in overall pump efficiency = $A + B \cdot Q + C \cdot (Q^2)$ [-]/(m ³ /d) ²]	0	0

Fittings and loss coefficients ('K' values)

Name	Default	Value
Pipe entrance (bellmouth)	0,0500	1,0000
90° bend	0,7500	5,0000
45° bend	0,3000	2,0000
Butterfly valve (open)	0,3000	1,0000
Non-return valve	1,0000	0
Outlet (bellmouth)	0,2000	1,0000

Aeration

Name	Default	Value
Surface pressure [kPa]	101,3250	101,3250
Fractional effective saturation depth (Fed) [-]	0,3250	0,3250
Supply gas CO2 content [vol. %]	0,0400	0,0400
Supply gas O2 [vol. %]	20,9500	20,9500
Off-gas CO2 [vol. %]	2,0000	2,0000
Off-gas O2 [vol. %]	18,8000	18,8000
Off-gas H2 [vol. %]	0	0
Off-gas NH3 [vol. %]	0	0
Off-gas CH4 [vol. %]	0	0
Off-gas N2O [vol. %]	0	0
Surface turbulence factor [-]	2,0000	2,0000
Set point controller gain []	1,0000	1,0000

Blower

Name	Default	Value
Intake filter pressure drop [kPa]	3,5000	3,5000
Pressure drop through distribution system (piping/valves) [kPa]	3,0000	3,0000
Adiabatic/polytropic compression exponent (1.4 for adiabatic)	1,4000	1,4000
'A' in blower efficiency = $A + B \cdot Q_a + C \cdot (Q_a^2)$ [-]	0,7500	0,7500
'B' in blower efficiency = $A + B \cdot Q_a + C \cdot (Q_a^2)$ [-]/(m3/hr (20C, 1 atm))]	0	0
'C' in blower efficiency = $A + B \cdot Q_a + C \cdot (Q_a^2)$ [-]/(m3/hr (20C, 1 atm))^2]	0	0



Diffuser

Name	Default	Value
k_1 in $C = k_1(PC)^{0.25} + k_2$	1,2400	1,2400
k_2 in $C = k_1(PC)^{0.25} + k_2$	0,8960	0,8960
Y in $Kla = C U_{sg} \wedge Y - U_{sg}$ in [m ³ /(m ² d)]	0,8880	0,8880
Area of one diffuser [m ²]	0,0410	0,0380
Diffuser mounting height [m]	0,2500	0,2500
Min. air flow rate per diffuser m ³ /hr (20C, 1 atm)	0,5000	0,5000
Max. air flow rate per diffuser m ³ /hr (20C, 1 atm)	10,0000	10,0000
'A' in diffuser pressure drop = $A + B*(Qa/Diff) + C*(Qa/Diff)^2$ [kPa]	3,0000	3,0000
'B' in diffuser pressure drop = $A + B*(Qa/Diff) + C*(Qa/Diff)^2$ [kPa/(m ³ /hr (20C, 1 atm))]	0	0
'C' in diffuser pressure drop = $A + B*(Qa/Diff) + C*(Qa/Diff)^2$ [kPa/(m ³ /hr (20C, 1 atm)) ²]	0	0

Surface aerators

Name	Default	Value
Surface aerator Std. oxygen transfer rate [kg O ₂ /(kW hr)]	1,50000	1,50000

Modified Vesilind

Name	Default	Value
Maximum Vesilind settling velocity (V_0) [m/d]	170,000	170,000
Vesilind hindered zone settling parameter (K) [L/g]	0,370	0,370
Clarification switching function [mg/L]	100,000	100,000
Specified TSS conc.for height calc. [mg/L]	2500,000	2500,000
Maximum compactability constant [mg/L]	15000,000	15000,000
Maximum compactability slope [L/mg]	0,010	0,010

Double exponential

Name	Default	Value
------	---------	-------



Maximum Vesilind settling velocity (Vo) [m/d]	410,000	410,000
Maximum (practical) settling velocity (Vo') [m/d]	270,000	270,000
Hindered zone settling parameter (Kh) [L/g]	0,400	0,400
Flocculent zone settling parameter (Kf) [L/g]	2,500	2,500
Maximum non-settleable TSS [mg/L]	20,0000	20,0000
Non-settleable fraction [-]	1,000E-3	1,000E-3
Specified TSS conc. for height calc. [mg/L]	2500,0000	2500,0000

Emission factors

Name	Default	Value
Carbon dioxide equivalence of nitrous oxide	296,0000	296,0000
Carbon dioxide equivalence of methane	23,0000	23,0000

Biofilm general

Name	Default	Value	
Attachment rate [g / (m2 d)]	8,0000	8,0000	1,0000
Attachment TSS half sat. [mg/L]	100,0000	100,0000	1,0000
Detachment rate [g/(m3 d)]	8000,0000	8000,0000	1,0000
Solids movement factor []	10,0000	10,0000	1,0000
Diffusion neta []	0,8000	0,8000	1,0000
Thin film limit [mm]	0,5000	0,5000	1,0000
Thick film limit [mm]	3,0000	3,0000	1,0000
Assumed Film thickness for tank volume correction (temp independent) [mm]	1,2500	1,2500	1,0000
Film surface area to media area ratio - Max.[]	1,0000	1,0000	1,0000
Minimum biofilm conc. for streamer formation [gTSS/m2]	4,0000	4,0000	1,0000

Maximum biofilm concentrations [mg/L]

Name	Default	Value	
Biomass - Ordinary heterotrophic	5,000E+4	5,000E+4	1,0000
Biomass - Methylotrophic	5,000E+4	5,000E+4	1,0000
Biomass - Ammonia oxidizing	1,000E+5	1,000E+5	1,0000



Biomass - Nitrite oxidizing	1,000E+5	1,000E+5	1,0000
Biomass - Anaerobic ammonia oxidizing	5,000E+4	5,000E+4	1,0000
Biomass - Phosphorus accumulating	5,000E+4	5,000E+4	1,0000
Biomass - Propionic acetogenic	5,000E+4	5,000E+4	1,0000
Biomass - Acetoclastic methanogenic	5,000E+4	5,000E+4	1,0000
Biomass - Hydrogenotrophic methanogenic	5,000E+4	5,000E+4	1,0000
Biomass - Endogenous products	3,000E+4	3,000E+4	1,0000
CODp - Slowly degradable particulate	5000,0000	5000,0000	1,0000
CODp - Slowly degradable colloidal	4000,0000	4000,0000	1,0000
CODp - Degradable external organics	5000,0000	5000,0000	1,0000
CODp - Undegradable non-cellulose	5000,0000	5000,0000	1,0000
CODp - Undegradable cellulose	5000,0000	5000,0000	1,0000
N - Particulate degradable organic	0	0	1,0000
P - Particulate degradable organic	0	0	1,0000
N - Particulate degradable external organics	0	0	1,0000
P - Particulate degradable external organics	0	0	1,0000
N - Particulate undegradable	0	0	1,0000
P - Particulate undegradable	0	0	1,0000
CODp - Stored PHA	5000,0000	5000,0000	1,0000
P - Releasable stored polyP	1,150E+6	1,150E+6	1,0000
P - Unreleasable stored polyP	1,150E+6	1,150E+6	1,0000
CODs - Complex readily degradable	0	0	1,0000
CODs - Acetate	0	0	1,0000
CODs - Propionate	0	0	1,0000
CODs - Methanol	0	0	1,0000
Gas - Dissolved hydrogen	0	0	1,0000
Gas - Dissolved methane	0	0	1,0000
N - Ammonia	0	0	1,0000
N - Soluble degradable organic	0	0	1,0000
Gas - Dissolved nitrous oxide	0	0	1,0000
N - Nitrite	0	0	1,0000
N - Nitrate	0	0	1,0000
Gas - Dissolved nitrogen	0	0	1,0000
P - Soluble phosphate	0	0	1,0000
CODs - Undegradable	0	0	1,0000
N - Soluble undegradable organic	0	0	1,0000
Influent inorganic suspended solids	1,300E+6	1,300E+6	1,0000
Precipitate - Struvite	8,500E+5	8,500E+5	1,0000
Precipitate - Brushite	1,165E+6	1,165E+6	1,0000
Precipitate - Hydroxy - apatite	1,600E+6	1,600E+6	1,0000
Precipitate - Vivianite	1,340E+6	1,340E+6	1,0000



HFO - High surface	5,000E+4	5,000E+4	1,0000
HFO - Low surface	5,000E+4	5,000E+4	1,0000
HFO - High with H2PO4- adsorbed	5,000E+4	5,000E+4	1,0000
HFO - Low with H2PO4- adsorbed	5,000E+4	5,000E+4	1,0000
HFO - Aged	5,000E+4	5,000E+4	1,0000
HFO - Low with H+ adsorbed	5,000E+4	5,000E+4	1,0000
HFO - High with H+ adsorbed	5,000E+4	5,000E+4	1,0000
HAO - High surface	5,000E+4	5,000E+4	1,0000
HAO - Low surface	5,000E+4	5,000E+4	1,0000
HAO - High with H2PO4- adsorbed	5,000E+4	5,000E+4	1,0000
HAO - Low with H2PO4- adsorbed	5,000E+4	5,000E+4	1,0000
HAO - Aged	5,000E+4	5,000E+4	1,0000
P - Bound on aged HMO	5,000E+4	5,000E+4	1,0000
Metal soluble - Magnesium	0	0	1,0000
Metal soluble - Calcium	0	0	1,0000
Metal soluble - Ferric	0	0	1,0000
Metal soluble - Ferrous	0	0	1,0000
Metal soluble - Aluminum	0	0	1,0000
Other Cations (strong bases)	0	0	1,0000
Other Anions (strong acids)	0	0	1,0000
Gas - Dissolved total CO2	0	0	1,0000
User defined - UD1	0	0	1,0000
User defined - UD2	0	0	1,0000
User defined - UD3	5,000E+4	5,000E+4	1,0000
User defined - UD4	5,000E+4	5,000E+4	1,0000
Biomass - Sulfur oxidizing	1,000E+5	1,000E+5	1,0000
Biomass - Sulfur reducing propionic acetogenic	5,000E+4	5,000E+4	1,0000
Biomass - Sulfur reducing acetotrophic	5,000E+4	5,000E+4	1,0000
Biomass - Sulfur reducing hydrogenotrophic	1,000E+5	1,000E+5	1,0000
Gas - Dissolved total sulfides	0	0	1,0000
S - Soluble sulfate	0	0	1,0000
S - Particulate elemental sulfur	5,000E+4	5,000E+4	1,0000
Precipitate - Ferrous sulfide	5,000E+4	5,000E+4	1,0000
CODp - Adsorbed hydrocarbon	5,000E+4	5,000E+4	1,0000
CODs - Degradable volatile ind. #1	0	0	1,0000
CODs - Degradable volatile ind. #2	0	0	1,0000
CODs - Degradable volatile ind. #3	0	0	1,0000
CODs - Soluble hydrocarbon	0	0	1,0000
Gas - Dissolved oxygen	0	0	1,0000



Effective diffusivities [m²/s]

Name	Default	Value	
Biomass - Ordinary heterotrophic	5,000E-14	5,000E-14	1,0290
Biomass - Methylothetic	5,000E-14	5,000E-14	1,0290
Biomass - Ammonia oxidizing	5,000E-14	5,000E-14	1,0290
Biomass - Nitrite oxidizing	5,000E-14	5,000E-14	1,0290
Biomass - Anaerobic ammonia oxidizing	5,000E-14	5,000E-14	1,0290
Biomass - Phosphorus accumulating	5,000E-14	5,000E-14	1,0290
Biomass - Propionic acetogenic	5,000E-14	5,000E-14	1,0290
Biomass - Acetoclastic methanogenic	5,000E-14	5,000E-14	1,0290
Biomass - Hydrogenotrophic methanogenic	5,000E-14	5,000E-14	1,0290
Biomass - Endogenous products	5,000E-14	5,000E-14	1,0290
CODp - Slowly degradable particulate	5,000E-14	5,000E-14	1,0290
CODp - Slowly degradable colloidal	5,000E-10	5,000E-10	1,0290
CODp - Degradable external organics	5,000E-14	5,000E-14	1,0290
CODp - Undegradable non-cellulose	5,000E-14	5,000E-14	1,0290
CODp - Undegradable cellulose	5,000E-14	5,000E-14	1,0290
N - Particulate degradable organic	5,000E-14	5,000E-14	1,0290
P - Particulate degradable organic	5,000E-14	5,000E-14	1,0290
N - Particulate degradable external organics	5,000E-14	5,000E-14	1,0290
P - Particulate degradable external organics	5,000E-14	5,000E-14	1,0290
N - Particulate undegradable	5,000E-14	5,000E-14	1,0290
P - Particulate undegradable	5,000E-14	5,000E-14	1,0290
CODp - Stored PHA	5,000E-14	5,000E-14	1,0290
P - Releasable stored polyP	5,000E-14	5,000E-14	1,0290
P - Unreleasable stored polyP	5,000E-14	5,000E-14	1,0290
CODs - Complex readily degradable	6,900E-10	6,900E-10	1,0290
CODs - Acetate	1,240E-9	1,240E-9	1,0290
CODs - Propionate	8,300E-10	8,300E-10	1,0290
CODs - Methanol	1,600E-9	1,600E-9	1,0290
Gas - Dissolved hydrogen	5,850E-9	5,850E-9	1,0290
Gas - Dissolved methane	1,963E-9	1,963E-9	1,0290
N - Ammonia	2,000E-9	2,000E-9	1,0290
N - Soluble degradable organic	1,370E-9	1,370E-9	1,0290
Gas - Dissolved nitrous oxide	1,607E-9	1,607E-9	1,0290
N - Nitrite	2,980E-9	2,980E-9	1,0290
N - Nitrate	2,980E-9	2,980E-9	1,0290
Gas - Dissolved nitrogen	1,900E-9	1,900E-9	1,0290
P - Soluble phosphate	2,000E-9	2,000E-9	1,0290

CODs - Undegradable	6,900E-10	6,900E-10	1,0290
N - Soluble undegradable organic	6,850E-10	6,850E-10	1,0290
Influent inorganic suspended solids	5,000E-14	5,000E-14	1,0290
Precipitate - Struvite	5,000E-14	5,000E-14	1,0290
Precipitate - Brushite	5,000E-14	5,000E-14	1,0290
Precipitate - Hydroxy - apatite	5,000E-14	5,000E-14	1,0290
Precipitate - Vivianite	5,000E-14	5,000E-14	1,0290
HFO - High surface	5,000E-14	5,000E-14	1,0290
HFO - Low surface	5,000E-14	5,000E-14	1,0290
HFO - High with H ₂ PO ₄ - adsorbed	5,000E-14	5,000E-14	1,0290
HFO - Low with H ₂ PO ₄ - adsorbed	5,000E-14	5,000E-14	1,0290
HFO - Aged	5,000E-14	5,000E-14	1,0290
HFO - Low with H ⁺ adsorbed	5,000E-14	5,000E-14	1,0290
HFO - High with H ⁺ adsorbed	5,000E-14	5,000E-14	1,0290
HAO - High surface	5,000E-14	5,000E-14	1,0290
HAO - Low surface	5,000E-14	5,000E-14	1,0290
HAO - High with H ₂ PO ₄ - adsorbed	5,000E-14	5,000E-14	1,0290
HAO - Low with H ₂ PO ₄ - adsorbed	5,000E-14	5,000E-14	1,0290
HAO - Aged	5,000E-14	5,000E-14	1,0290
P - Bound on aged HMO	5,000E-14	5,000E-14	1,0290
Metal soluble - Magnesium	7,200E-10	7,200E-10	1,0290
Metal soluble - Calcium	7,200E-10	7,200E-10	1,0290
Metal soluble - Ferric	4,800E-10	4,800E-10	1,0290
Metal soluble - Ferrous	4,800E-10	4,800E-10	1,0290
Metal soluble - Aluminum	4,800E-10	4,800E-10	1,0290
Other Cations (strong bases)	1,440E-9	1,440E-9	1,0290
Other Anions (strong acids)	1,440E-9	1,440E-9	1,0290
Gas - Dissolved total CO ₂	1,960E-9	1,960E-9	1,0290
User defined - UD1	6,900E-10	6,900E-10	1,0290
User defined - UD2	6,900E-10	6,900E-10	1,0290
User defined - UD3	5,000E-14	5,000E-14	1,0290
User defined - UD4	5,000E-14	5,000E-14	1,0290
Biomass - Sulfur oxidizing	5,000E-14	5,000E-14	1,0290
Biomass - Sulfur reducing propionic acetogenic	5,000E-14	5,000E-14	1,0290
Biomass - Sulfur reducing acetotrophic	5,000E-14	5,000E-14	1,0290
Biomass - Sulfur reducing hydrogenotrophic	5,000E-14	5,000E-14	1,0290
Gas - Dissolved total sulfides	1,530E-9	1,530E-9	1,0290
S - Soluble sulfate	2,130E-10	2,130E-10	1,0290
S - Particulate elemental sulfur	5,000E-14	5,000E-14	1,0290
Precipitate - Ferrous sulfide	5,000E-14	5,000E-14	1,0290
CODp - Adsorbed hydrocarbon	5,000E-14	5,000E-14	1,0290



CODs - Degradable volatile ind. #1	7,240E-10	7,240E-10	1,0290
CODs - Degradable volatile ind. #2	8,900E-10	8,900E-10	1,0290
CODs - Degradable volatile ind. #3	7,960E-10	7,960E-10	1,0290
CODs - Soluble hydrocarbon	7,120E-10	7,120E-10	1,0290
Gas - Dissolved oxygen	2,500E-9	2,500E-9	1,0290

EPS Strength coefficients []

Name	Default	Value	
Biomass - Ordinary heterotrophic	1,0000	1,0000	1,0000
Biomass - Methylothetic	1,0000	1,0000	1,0000
Biomass - Ammonia oxidizing	5,0000	5,0000	1,0000
Biomass - Nitrite oxidizing	25,0000	25,0000	1,0000
Biomass - Anaerobic ammonia oxidizing	10,0000	10,0000	1,0000
Biomass - Phosphorus accumulating	1,0000	1,0000	1,0000
Biomass - Propionic acetogenic	1,0000	1,0000	1,0000
Biomass - Acetoclastic methanogenic	1,0000	1,0000	1,0000
Biomass - Hydrogenotrophic methanogenic	1,0000	1,0000	1,0000
Biomass - Endogenous products	1,0000	1,0000	1,0000
CODp - Slowly degradable particulate	1,0000	1,0000	1,0000
CODp - Slowly degradable colloidal	1,0000	1,0000	1,0000
CODp - Degradable external organics	1,0000	1,0000	1,0000
CODp - Undegradable non-cellulose	1,0000	1,0000	1,0000
CODp - Undegradable cellulose	1,0000	1,0000	1,0000
N - Particulate degradable organic	1,0000	1,0000	1,0000
P - Particulate degradable organic	1,0000	1,0000	1,0000
N - Particulate degradable external organics	1,0000	1,0000	1,0000
P - Particulate degradable external organics	1,0000	1,0000	1,0000
N - Particulate undegradable	1,0000	1,0000	1,0000
P - Particulate undegradable	1,0000	1,0000	1,0000
CODp - Stored PHA	1,0000	1,0000	1,0000
P - Releasable stored polyP	1,0000	1,0000	1,0000
P - Unreleasable stored polyP	1,0000	1,0000	1,0000
CODs - Complex readily degradable	0	0	1,0000
CODs - Acetate	0	0	1,0000
CODs - Propionate	0	0	1,0000
CODs - Methanol	0	0	1,0000
Gas - Dissolved hydrogen	0	0	1,0000
Gas - Dissolved methane	0	0	1,0000



N - Ammonia	0	0	1,0000
N - Soluble degradable organic	0	0	1,0000
Gas - Dissolved nitrous oxide	0	0	1,0000
N - Nitrite	0	0	1,0000
N - Nitrate	0	0	1,0000
Gas - Dissolved nitrogen	0	0	1,0000
P - Soluble phosphate	0	0	1,0000
CODs - Undegradable	0	0	1,0000
N - Soluble undegradable organic	0	0	1,0000
Influent inorganic suspended solids	0,3300	0,3300	1,0000
Precipitate - Struvite	1,0000	1,0000	1,0000
Precipitate - Brushite	1,0000	1,0000	1,0000
Precipitate - Hydroxy - apatite	1,0000	1,0000	1,0000
Precipitate - Vivianite	1,0000	1,0000	1,0000
HFO - High surface	1,0000	1,0000	1,0000
HFO - Low surface	1,0000	1,0000	1,0000
HFO - High with H2PO4- adsorbed	1,0000	1,0000	1,0000
HFO - Low with H2PO4- adsorbed	1,0000	1,0000	1,0000
HFO - Aged	1,0000	1,0000	1,0000
HFO - Low with H+ adsorbed	1,0000	1,0000	1,0000
HFO - High with H+ adsorbed	1,0000	1,0000	1,0000
HAO - High surface	1,0000	1,0000	1,0000
HAO - Low surface	1,0000	1,0000	1,0000
HAO - High with H2PO4- adsorbed	1,0000	1,0000	1,0000
HAO - Low with H2PO4- adsorbed	1,0000	1,0000	1,0000
HAO - Aged	1,0000	1,0000	1,0000
P - Bound on aged HMO	1,0000	1,0000	1,0000
Metal soluble - Magnesium	0	0	1,0000
Metal soluble - Calcium	0	0	1,0000
Metal soluble - Ferric	0	0	1,0000
Metal soluble - Ferrous	0	0	1,0000
Metal soluble - Aluminum	0	0	1,0000
Other Cations (strong bases)	0	0	1,0000
Other Anions (strong acids)	0	0	1,0000
Gas - Dissolved total CO2	0	0	1,0000
User defined - UD1	0	0	1,0000
User defined - UD2	0	0	1,0000
User defined - UD3	1,0000	1,0000	1,0000
User defined - UD4	1,0000	1,0000	1,0000
Biomass - Sulfur oxidizing	1,0000	1,0000	1,0000
Biomass - Sulfur reducing propionic acetogenic	1,0000	1,0000	1,0000



Biomass - Sulfur reducing acetotrophic	1,0000	1,0000	1,0000
Biomass - Sulfur reducing hydrogenotrophic	1,0000	1,0000	1,0000
Gas - Dissolved total sulfides	0	0	1,0000
S - Soluble sulfate	0	0	1,0000
S - Particulate elemental sulfur	1,0000	1,0000	1,0000
Precipitate - Ferrous sulfide	1,0000	1,0000	1,0000
CODp - Adsorbed hydrocarbon	1,0000	1,0000	1,0000
CODs - Degradable volatile ind. #1	0	0	1,0000
CODs - Degradable volatile ind. #2	0	0	1,0000
CODs - Degradable volatile ind. #3	0	0	1,0000
CODs - Soluble hydrocarbon	0	0	1,0000
Gas - Dissolved oxygen	0	0	1,0000



Appendix 12: BioWin user and configuration data – Summer Load

Project details

Project name:

Steady State Design Retrofit Average Flow Weighed Influent Data Summer 2019

Project ref.: Summer Load

Plant name: WWTP Porec-South Jug (POSO)

Username: ASM Design

Created: 9-3-2021

Saved: 9-5-2021

Steady state solution

Temperature: 20,0°C

Flowsheet

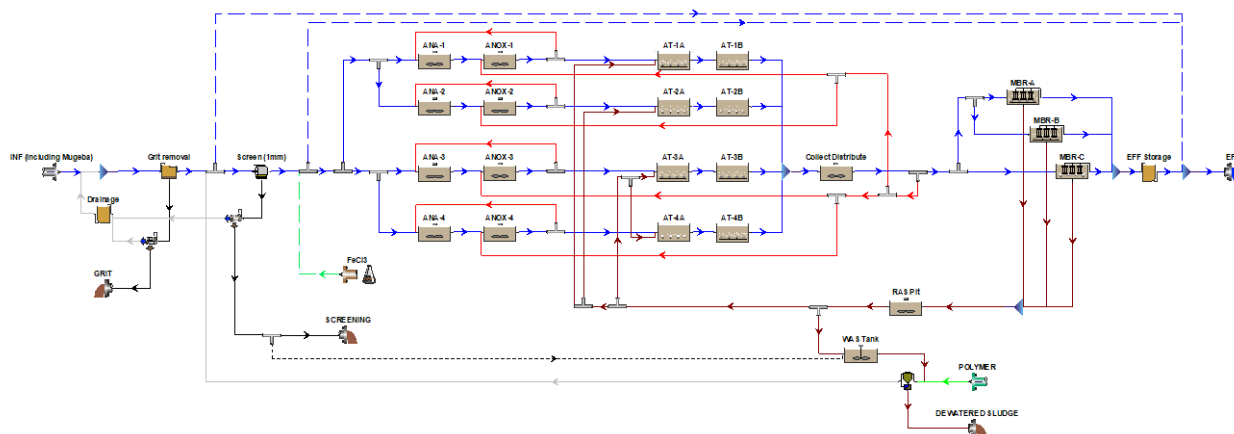

Configuration information for all Bioreactor units

Physical data



Element name	Volume [m3]	Area [m2]	Depth [m]	# of diffusers
ANA-1	200,0000	36,3636	5,500	Un-aerated
ANOX-1	175,0000	31,8182	5,500	Un-aerated
AT-1A	180,0000	32,7273	5,500	163
ANA-3	200,0000	36,3636	5,500	Un-aerated
ANOX-3	175,0000	31,8182	5,500	Un-aerated
AT-3A	180,0000	32,7273	5,500	163
ANA-4	200,0000	36,3636	5,500	Un-aerated
ANOX-4	175,0000	31,8182	5,500	Un-aerated
AT-4A	180,0000	32,7273	5,500	163
Collect Distribute	198,0000	36,0000	5,500	Un-aerated
RAS Pit	81,8230	40,9115	2,000	Un-aerated
WAS Tank	150,0000	2,8302	53,000	Un-aerated
ANA-2	200,0000	36,3636	5,500	Un-aerated
ANOX-2	175,0000	31,8182	5,500	Un-aerated
AT-2A	180,0000	32,7273	5,500	163
AT-1B	180,0000	32,7273	5,500	163
AT-2B	180,0000	32,7273	5,500	163
AT-3B	180,0000	32,7273	5,500	163
AT-4B	180,0000	32,7273	5,500	163

Operating data Average (flow/time weighted as required)

Element name	Average DO Setpoint [mg/L]
ANA-1	0
ANOX-1	0
AT-1A	0,5
ANA-3	0
ANOX-3	0
AT-3A	0,5
ANA-4	0
ANOX-4	0
AT-4A	0,5
Collect Distribute	0
RAS Pit	0
WAS Tank	0
ANA-2	0
ANOX-2	0
AT-2A	0,5



AT-1B	2,0
AT-2B	2,0
AT-3B	2,0
AT-4B	2,0

Aeration equipment parameters

Element name	k_1 in $C = k_1(PC)^{0.25} + k_2$	k_2 in $C = k_1(PC)^{0.25} + k_2$	Y in $Kla = C U_{sg} \cdot Y - U_{sg}$ in $[m^3/(m^2 d)]$	Area of one diffuser	Diffuser mounting height	Min. air flow rate per diffuser m^3/hr (20C, 1 atm)	Max. air flow rate per diffuser m^3/hr (20C, 1 atm)	'A' in diffuser pressure drop = $A + B^*(Qa/Diff)^2 + C^*(Qa/Diff)^2$	'B' in diffuser pressure drop = $A + B^*(Qa/Diff)^2 + C^*(Qa/Diff)^2$	'C' in diffuser pressure drop = $A + B^*(Qa/Diff)^2 + C^*(Qa/Diff)^2$
ANA-1	1,2400	0,8960	0,8880	0,0380	0,2500	0,5000	10,0000	3,0000	0	0
ANOX-1	1,2400	0,8960	0,8880	0,0380	0,2500	0,5000	10,0000	3,0000	0	0
AT-1A	1,2400	0,8960	0,8880	0,0380	0,2500	0,5000	10,0000	3,0000	0	0
ANA-3	1,2400	0,8960	0,8880	0,0380	0,2500	0,5000	10,0000	3,0000	0	0
ANOX-3	1,2400	0,8960	0,8880	0,0380	0,2500	0,5000	10,0000	3,0000	0	0
AT-3A	1,2400	0,8960	0,8880	0,0380	0,2500	0,5000	10,0000	3,0000	0	0
ANA-4	1,2400	0,8960	0,8880	0,0380	0,2500	0,5000	10,0000	3,0000	0	0
ANOX-4	1,2400	0,8960	0,8880	0,0380	0,2500	0,5000	10,0000	3,0000	0	0
AT-4A	1,2400	0,8960	0,8880	0,0380	0,2500	0,5000	10,0000	3,0000	0	0
Collect Distribute	1,2400	0,8960	0,8880	0,0380	0,2500	0,5000	10,0000	3,0000	0	0
RAS Pit	1,2400	0,8960	0,8880	0,0380	0,2500	0,5000	10,0000	3,0000	0	0
WAS Tank	1,2400	0,8960	0,8880	0,0380	0,2500	0,5000	10,0000	3,0000	0	0
ANA-2	1,2400	0,8960	0,8880	0,0380	0,2500	0,5000	10,0000	3,0000	0	0
ANOX-2	1,2400	0,8960	0,8880	0,0380	0,2500	0,5000	10,0000	3,0000	0	0
AT-2A	1,2400	0,8960	0,8880	0,0380	0,2500	0,5000	10,0000	3,0000	0	0
AT-1B	1,2400	0,8960	0,8880	0,0380	0,2500	0,5000	10,0000	3,0000	0	0
AT-2B	1,2400	0,8960	0,8880	0,0380	0,2500	0,5000	10,0000	3,0000	0	0
AT-3B	1,2400	0,8960	0,8880	0,0380	0,2500	0,5000	10,0000	3,0000	0	0
AT-4B	1,2400	0,8960	0,8880	0,0380	0,2500	0,5000	10,0000	3,0000	0	0

Configuration information for all Bioreactor - Membrane units

Physical data



Element name	Volume [m3]	Area [m2]	Depth [m]	# of diffusers	# of cassettes	Displaced volume / cassette [m3/cassette]	Membrane area / cassette [m2/cassette]	Total displaced volume [m3]	Membrane surface area [m2]
MBR-A	75,0000	13,6364	5,500	150	3,00	1,690	1650,00	5,07	4950,00
MBR-B	75,0000	13,6364	5,500	102	3,00	1,690	1100,00	5,07	3300,00
MBR-C	75,0000	13,6364	5,500	102	3,00	1,690	1100,00	5,07	3300,00

Operating data Average (flow/time weighted as required)

Element name	Split method	Average Split specification
MBR-A	Flow paced	33,00 %
MBR-B	Flow paced	33,00 %
MBR-C	Flow paced	33,00 %

Element name	Average Air flow rate [m3/hr (20C, 1 atm)]
MBR-A	980,0
MBR-B	980,0
MBR-C	980,0

Aeration equipment parameters

Element name	k_1 in C = $k_1(PC)^{0.25} + k_2$	k_2 in C = $k_1(PC)^{0.25} + k_2$	Y in $Kla = C U_{sg} \cdot Y - U_{sg}$ in [m3/(m2 d)]	Area of one diffuser	Diffuser mounting height	Min. air flow rate per diffuser m3/hr (20C, 1 atm)	Max. air flow rate per diffuser m3/hr (20C, 1 atm)	'A' in diffuser pressure drop = A + $B^*(Qa/Diff)^2 + C^*(Qa/Diff)^2$	'B' in diffuser pressure drop = A + $B^*(Qa/Diff)^2 + C^*(Qa/Diff)^2$	'C' in diffuser pressure drop = A + $B^*(Qa/Diff)^2 + C^*(Qa/Diff)^2$
MBR-A	0,0500	0,3800	1,0000	0,0500	0,2500	2,0000	50,0000	1,0000	0	0
MBR-B	0,0500	0,3800	1,0000	0,0500	0,2500	2,0000	50,0000	1,0000	0	0
MBR-C	0,0500	0,3800	1,0000	0,0500	0,2500	2,0000	50,0000	1,0000	0	0

Element name	Surface pressure [kPa]	Fractional effective saturation depth (Fed) [-]
--------------	------------------------	---



MBR-A	101,3250	0,3000
MBR-B	101,3250	0,3000
MBR-C	101,3250	0,3000

Element name	Supply gas CO2 content [vol. %]	Supply gas O2 [vol. %]	Off-gas CO2 [vol. %]	Off-gas O2 [vol. %]	Off-gas H2 [vol. %]	Off-gas NH3 [vol. %]	Off-gas CH4 [vol. %]	Off-gas N2O [vol. %]	Surface turbulence factor [-]
MBR-A	0,0400	20,9500	1,2000	19,9000	0	0	0	0	2,0000
MBR-B	0,0400	20,9500	1,2000	19,9000	0	0	0	0	2,0000
MBR-C	0,0400	20,9500	1,2000	19,9000	0	0	0	0	2,0000

Configuration information for all Effluent units

Configuration information for all Separator - Grit tank units

Physical data

Element name	Volume [m3]	Area [m2]	Depth [m]
Grit removal	3200,4000	12,6000	254,000

Operating data Average (flow/time weighted as required)

Element name	Split method	Average Split specification
Grit removal	Flow paced	0,01 %

Element name	Percent removal	Blanket fraction
Grit removal	5,00	0,10

Configuration information for all Influent - COD units



Operating data Average (flow/time weighted as required)

Element name	INF (including Mugeba)
Flow	5849,4
COD - Total mgCOD/L	888,40
N - Total Kjeldahl Nitrogen mgN/L	87,20
P - Total P mgP/L	11,40
S - Total S mgS/L	10,00
N - Nitrate mgN/L	0,50
pH	7,30
Alkalinity mmol/L	7,46
ISS Total mgISS/L	32,00
Metal soluble - Calcium mg/L	80,00
Metal soluble - Magnesium mg/L	15,00
Gas - Dissolved oxygen mg/L	0

Element name	INF (including Mugeba)
Fbs - Readily biodegradable (including Acetate) [gCOD/g of total COD]	0,2323
Fac - Acetate [gCOD/g of readily biodegradable COD]	0,2243
Fxsp - Non-colloidal slowly biodegradable [gCOD/g of slowly degradable COD]	0,8927
Fus - Unbiodegradable soluble [gCOD/g of total COD]	0,0281
Fup - Unbiodegradable particulate [gCOD/g of total COD]	0,1055
Fcel - Cellulose fraction of unbiodegradable particulate [gCOD/gCOD]	0,5930
Fna - Ammonia [gNH ₃ -N/gTKN]	0,7729
Fnox - Particulate organic nitrogen [gN/g Organic N]	0,1628
Fnus - Soluble unbiodegradable TKN [gN/gTKN]	0,0100
FupN - N:COD ratio for unbiodegradable part. COD [gN/gCOD]	0,0700
Fpo4 - Phosphate [gPO ₄ -P/gTP]	0,5526
FupP - P:COD ratio for unbiodegradable part. COD [gP/gCOD]	1,000E-3
Fsr - Reduced sulfur [H ₂ S] [gS/gS]	0,1500
FZbh - Ordinary heterotrophic COD fraction [gCOD/g of total COD]	0,0253
FZbm - Methylophilic COD fraction [gCOD/g of total COD]	1,000E-4
FZao - Ammonia oxidizing COD fraction [gCOD/g of total COD]	1,000E-4
FZno - Nitrite oxidizing COD fraction [gCOD/g of total COD]	1,000E-4
FZaao - Anaerobic ammonia oxidizing COD fraction [gCOD/g of total COD]	1,000E-4
FZppa - Phosphorus accumulating COD fraction [gCOD/g of total COD]	1,000E-4
FZpa - Propionic acetogenic COD fraction [gCOD/g of total COD]	1,000E-4
FZam - Acetoclastic methanogenic COD fraction [gCOD/g of total COD]	1,000E-4
FZhm - Hydrogenotrophic methanogenic COD fraction [gCOD/g of total COD]	1,000E-4

FZso - Sulfur oxidizing COD fraction [gCOD/g of total COD]	1,000E-4
FZsrpa - Sulfur reducing propionic acetogenic COD fraction [gCOD/g of total COD]	1,000E-4
FZsra - Sulfur reducing acetotrophic COD fraction [gCOD/g of total COD]	1,000E-4
FZsrh - Sulfur reducing hydrogenotrophic COD fraction [gCOD/g of total COD]	1,000E-4
FZe - Endogenous products COD fraction [gCOD/g of total COD]	0

Configuration information for all Input - Iron (ferric) units

Operating data Average (flow/time weighted as required)

Element name	FeCl3
Biomass - Ordinary heterotrophic [mgCOD/L]	0
Biomass - Methyloctrophic [mgCOD/L]	0
Biomass - Ammonia oxidizing [mgCOD/L]	0
Biomass - Nitrite oxidizing [mgCOD/L]	0
Biomass - Anaerobic ammonia oxidizing [mgCOD/L]	0
Biomass - Phosphorus accumulating [mgCOD/L]	0
Biomass - Propionic acetogenic [mgCOD/L]	0
Biomass - Acetoclastic methanogenic [mgCOD/L]	0
Biomass - Hydrogenotrophic methanogenic [mgCOD/L]	0
Biomass - Endogenous products [mgCOD/L]	0
CODp - Slowly degradable particulate [mgCOD/L]	0
CODp - Slowly degradable colloidal [mgCOD/L]	0
CODp - Degradable external organics [mgCOD/L]	0
CODp - Undegradable non-cellulose [mgCOD/L]	0
CODp - Undegradable cellulose [mgCOD/L]	0
N - Particulate degradable organic [mgN/L]	0
P - Particulate degradable organic [mgP/L]	0
N - Particulate degradable external organics [mgN/L]	0
P - Particulate degradable external organics [mgP/L]	0
N - Particulate undegradable [mgN/L]	0
P - Particulate undegradable [mgP/L]	0
CODp - Stored PHA [mgCOD/L]	0
P - Releasable stored polyP [mgP/L]	0
P - Unreleasable stored polyP [mgP/L]	0
CODs - Complex readily degradable [mgCOD/L]	0
CODs - Acetate [mgCOD/L]	0
CODs - Propionate [mgCOD/L]	0



CODs - Methanol [mgCOD/L]	0
Gas - Dissolved hydrogen [mgCOD/L]	0
Gas - Dissolved methane [mg/L]	0
N - Ammonia [mgN/L]	0
N - Soluble degradable organic [mgN/L]	0
Gas - Dissolved nitrous oxide [mgN/L]	0
N - Nitrite [mgN/L]	0
N - Nitrate [mgN/L]	0
Gas - Dissolved nitrogen [mgN/L]	0
P - Soluble phosphate [mgP/L]	0
CODs - Undegradable [mgCOD/L]	0
N - Soluble undegradable organic [mgN/L]	0
Influent inorganic suspended solids [mgISS/L]	0
Precipitate - Struvite [mgISS/L]	0
Precipitate - Brushite [mgISS/L]	0
Precipitate - Hydroxy - apatite [mgISS/L]	0
Precipitate - Vivianite [mgISS/L]	0
HFO - High surface [mg/L]	0
HFO - Low surface [mg/L]	0
HFO - High with H ₂ PO ₄ - adsorbed [mg/L]	0
HFO - Low with H ₂ PO ₄ - adsorbed [mg/L]	0
HFO - Aged [mg/L]	0
HFO - Low with H ⁺ adsorbed [mg/L]	0
HFO - High with H ⁺ adsorbed [mg/L]	0
HAO - High surface [mg/L]	0
HAO - Low surface [mg/L]	0
HAO - High with H ₂ PO ₄ - adsorbed [mg/L]	0
HAO - Low with H ₂ PO ₄ - adsorbed [mg/L]	0
HAO - Aged [mg/L]	0
P - Bound on aged HMO [mgP/L]	0
Metal soluble - Magnesium [mg/L]	0
Metal soluble - Calcium [mg/L]	0
Metal soluble - Ferric [mg/L]	150000,00
Metal soluble - Ferrous [mg/L]	0
Metal soluble - Aluminum [mg/L]	0
Other Cations (strong bases) [meq/L]	5,00
Other Anions (strong acids) [meq/L]	8062,73
Gas - Dissolved total CO ₂ [mmol/L]	7,00
User defined - UD1 [mg/L]	0
User defined - UD2 [mg/L]	0
User defined - UD3 [mgVSS/L]	0



User defined - UD4 [mgSS/L]	0
Biomass - Sulfur oxidizing [mgCOD/L]	0
Biomass - Sulfur reducing propionic acetogenic [mgCOD/L]	0
Biomass - Sulfur reducing acetotrophic [mgCOD/L]	0
Biomass - Sulfur reducing hydrogenotrophic [mgCOD/L]	0
Gas - Dissolved total sulfides [mgS/L]	0
S - Soluble sulfate [mgS/L]	0
S - Particulate elemental sulfur [mgS/L]	0
Precipitate - Ferrous sulfide [mgSS/L]	0
CODp - Adsorbed hydrocarbon [mgCOD/L]	0
CODs - Degradable volatile ind. #1 [mgCOD/L]	0
CODs - Degradable volatile ind. #2 [mgCOD/L]	0
CODs - Degradable volatile ind. #3 [mgCOD/L]	0
CODs - Soluble hydrocarbon [mgCOD/L]	0
Gas - Dissolved oxygen [mg/L]	0
Flow	0

Configuration information for all Separator - Dewatering unit units

Operating data Average (flow/time weighted as required)

Element name	Split method	Average Split specification
Grit Compacter	Flow paced	0,01 %
Screening Compacter	Flow paced	0,01 %

Element name	Percent removal
Grit Compacter	100,00
Screening Compacter	100,00

Configuration information for all Separator - Microscreen units

Operating data Average (flow/time weighted as required)



Element name	Split method	Average Split specification
Screen (1mm)	Flow paced	0,02 %

Element name	Percent removal
Screen (1mm)	5,00

Configuration information for all Separator - Cyclone (dewatering) units

Operating data Average (flow/time weighted as required)

Element name	Split method	Average Split specification
Dewatering Centrifuge	Fraction	0,04

Element name	Percent removal
Dewatering Centrifuge	95,00

Configuration information for all Sludge units

Configuration information for all Splitter units

Operating data Average (flow/time weighted as required)

Element name	Split method	Average Split specification
ANA-R1	Flow paced	25,00 %
ANA-R3	Flow paced	25,00 %
ANA-R4	Flow paced	25,00 %
MBR Distribute 1	Fraction	0,67
AS Emergency Bypass	Bypass	7890
INF Distributer 1	Fraction	0,50



INF Distributer 3	Fraction	0,50
Screen Emergency Bypass	Bypass	14640
ANOX-R1	Flow paced	270,00 %
ANOX-R2	Fraction	0,50
ANOX-R4	Fraction	0,50
RAS Splitter 3	Fraction	0,50
WAS Splitter	Flowrate [Side]	175
RAS Splitter 1	Fraction	0,50
SCREENING Splitter	Flowrate [Side]	0
MBR Distribute 2	Fraction	0,50
INF Distributer 2	Fraction	0,50
ANOX-R3	Fraction	0,50
ANA-R2	Flow paced	25,00 %
RAS Splitter 2	Fraction	0,50

Configuration information for all Influent - State variable units

Operating data Average (flow/time weighted as required)

Element name	POLYMER
Biomass - Ordinary heterotrophic [mgCOD/L]	0
Biomass - Methylothetic [mgCOD/L]	0
Biomass - Ammonia oxidizing [mgCOD/L]	0
Biomass - Nitrite oxidizing [mgCOD/L]	0
Biomass - Anaerobic ammonia oxidizing [mgCOD/L]	0
Biomass - Phosphorus accumulating [mgCOD/L]	0
Biomass - Propionic acetogenic [mgCOD/L]	0
Biomass - Acetoclastic methanogenic [mgCOD/L]	0
Biomass - Hydrogenotrophic methanogenic [mgCOD/L]	0
Biomass - Endogenous products [mgCOD/L]	0
CODp - Slowly degradable particulate [mgCOD/L]	18180,00
CODp - Slowly degradable colloidal [mgCOD/L]	0
CODp - Degradable external organics [mgCOD/L]	0
CODp - Undegradable non-cellulose [mgCOD/L]	0
CODp - Undegradable cellulose [mgCOD/L]	0
N - Particulate degradable organic [mgN/L]	0
P - Particulate degradable organic [mgP/L]	0
N - Particulate degradable external organics [mgN/L]	0



P - Particulate degradable external organics [mgP/L]	0
N - Particulate undegradable [mgN/L]	0
P - Particulate undegradable [mgP/L]	0
CODp - Stored PHA [mgCOD/L]	0
P - Releasable stored polyP [mgP/L]	0
P - Unreleasable stored polyP [mgP/L]	0
CODs - Complex readily degradable [mgCOD/L]	0
CODs - Acetate [mgCOD/L]	0
CODs - Propionate [mgCOD/L]	0
CODs - Methanol [mgCOD/L]	0
Gas - Dissolved hydrogen [mgCOD/L]	0
Gas - Dissolved methane [mg/L]	0
N - Ammonia [mgN/L]	0
N - Soluble degradable organic [mgN/L]	0
Gas - Dissolved nitrous oxide [mgN/L]	0
N - Nitrite [mgN/L]	0
N - Nitrate [mgN/L]	0
Gas - Dissolved nitrogen [mgN/L]	0
P - Soluble phosphate [mgP/L]	0
CODs - Undegradable [mgCOD/L]	0
N - Soluble undegradable organic [mgN/L]	0
Influent inorganic suspended solids [mgISS/L]	0
Precipitate - Struvite [mgISS/L]	0
Precipitate - Brushite [mgISS/L]	0
Precipitate - Hydroxy - apatite [mgISS/L]	0
Precipitate - Vivianite [mgISS/L]	0
HFO - High surface [mg/L]	0
HFO - Low surface [mg/L]	0
HFO - High with H2PO4- adsorbed [mg/L]	0
HFO - Low with H2PO4- adsorbed [mg/L]	0
HFO - Aged [mg/L]	0
HFO - Low with H+ adsorbed [mg/L]	0
HFO - High with H+ adsorbed [mg/L]	0
HAO - High surface [mg/L]	0
HAO - Low surface [mg/L]	0
HAO - High with H2PO4- adsorbed [mg/L]	0
HAO - Low with H2PO4- adsorbed [mg/L]	0
HAO - Aged [mg/L]	0
P - Bound on aged HMO [mgP/L]	0
Metal soluble - Magnesium [mg/L]	0
Metal soluble - Calcium [mg/L]	0



Metal soluble - Ferric [mg/L]	0
Metal soluble - Ferrous [mg/L]	0
Metal soluble - Aluminum [mg/L]	0
Other Cations (strong bases) [meq/L]	0
Other Anions (strong acids) [meq/L]	0
Gas - Dissolved total CO2 [mmol/L]	0
User defined - UD1 [mg/L]	0
User defined - UD2 [mg/L]	0
User defined - UD3 [mgVSS/L]	0
User defined - UD4 [mgISS/L]	0
Biomass - Sulfur oxidizing [mgCOD/L]	0
Biomass - Sulfur reducing propionic acetogenic [mgCOD/L]	0
Biomass - Sulfur reducing acetotrophic [mgCOD/L]	0
Biomass - Sulfur reducing hydrogenotrophic [mgCOD/L]	0
Gas - Dissolved total sulfides [mgS/L]	0
S - Soluble sulfate [mgS/L]	0
S - Particulate elemental sulfur [mgS/L]	0
Precipitate - Ferrous sulfide [mgISS/L]	0
CODp - Adsorbed hydrocarbon [mgCOD/L]	0
CODs - Degradable volatile ind. #1 [mgCOD/L]	0
CODs - Degradable volatile ind. #2 [mgCOD/L]	0
CODs - Degradable volatile ind. #3 [mgCOD/L]	0
CODs - Soluble hydrocarbon [mgCOD/L]	0
Gas - Dissolved oxygen [mg/L]	0
Flow	0,65

Configuration information for all Equalization Tank units

Physical data

Element name	Volume[m3]	Area[m2]	Depth[m]
EFF Storage	2150,0000	390,9091	5,500
Drainage	27,0000	9,0000	3,000

BioWin Album



Album page - Loads Overview

Elements	Flow [m3/d]	Total suspended solids [kg /d]	Volatile suspended solids [kg /d]	ISS Total [kg /d]	BOD - Total Carbonaceous [kg /d]	COD - Total [kg /d]	N - Total N [kg N/d]	P - Total P [kg P/d]
INF (including Mugeba)	5849,40	2598,34	2411,16	187,18	2714,88	5196,61	512,99	66,68
Drainage	0,94	0	0	0	0,15	0,27	0,07	0,01
GRIT	0,29	8,42	0,24	8,18	0,22	0,44	0,03	0,00
SCREENING	0,47	312,81	302,93	9,88	89,61	405,64	8,72	1,76
Dewatering Centrifuge	168,27	87,59	69,06	18,54	34,87	111,51	8,66	18,24
Screen (1mm)	6016,91	2364,71	2177,04	187,66	2659,91	4902,03	512,90	83,16
ANA-1	2966,58	6146,68	5079,18	1067,50	2939,17	7383,53	528,99	275,96
ANOX-1	6914,92	26525,18	20800,27	5724,91	10937,70	29280,15	1899,16	1206,62
AT-1A	6856,55	35411,33	27414,28	7997,05	14175,20	38457,43	2458,42	1616,14
AT-1B	6856,55	35399,79	27290,82	8108,96	14041,63	38265,89	2452,23	1616,14
Collect Distribute	27426,20	141576,50	109089,61	32486,89	56070,58	152927,93	9766,90	6464,55
MBR-A	1943,43	0	0	0	2,10	59,35	20,76	0,10
EFF Storage	5841,91	0	0	0	6,30	178,39	62,29	0,31
EFF	5841,91	0,00	0,00	0,00	6,31	178,40	62,29	0,31
RAS Pit	5790,91	59766,68	45942,45	13824,23	23437,72	64197,24	4048,58	2741,63
WAS Tank	175,00	1743,94	1373,29	370,65	689,57	1932,33	121,43	82,85
DEWATERED SLUDGE	7,38	1664,27	1312,11	352,17	661,73	1832,64	112,78	64,61
FeCl3	0	0	0	0	0	0	0	0
POLYMER	0,65	7,93	7,88	0,05	7,04	11,82	0	0

Album page - Loads

Elements	INF (including Mugeba)	GRIT	SCREENING	EFF	DEWATERED SLUDGE	FeCl3	POLYMER
Flow [m3/d]	5849,40	0,29	0,47	5841,91	7,38	0	0,65
Total suspended solids [kg /d]	2598,34	8,42	312,81	0,00	1664,27	0	7,93
Volatile suspended solids [kg /d]	2411,16	0,24	302,93	0,00	1312,11	0	7,88
ISS Total [kg /d]	187,18	8,18	9,88	0,00	352,17	0	0,05
BOD - Total Carbonaceous [kg /d]	2714,88	0,22	89,61	6,31	661,73	0	7,04
COD - Total [kg /d]	5196,61	0,44	405,64	178,40	1832,64	0	11,82

N - Total N [kg N/d]	512,99	0,03	8,72	62,29	112,78	0	0
P - Total P [kg P/d]	66,68	0,00	1,76	0,31	64,61	0	0
Total iron (all forms) [kg Me/d]	0	0,00	0,00	0,00	0,00	0	0

Album page - Concentration Overview

Elements	Flow [m3/d]	Total suspended solids [mg/L]	Volatile suspended solids [mg/L]	ISS Total [mg/L]	BOD - Total Carbonaceous [mg/L]	COD - Total [mg/L]	N - Total N [mgN/L]	P - Total P [mgP/L]
INF (including Mugeba)	5849,40	444,21	412,21	32,00	464,13	888,40	87,70	11,40
Drainage	0,94	0	0	0	160,76	285,42	79,76	7,88
GRIT	0,29	28784,65	824,28	27960,37	764,26	1487,35	94,39	16,50
SCREENING	0,47	668458,45	647351,78	21106,68	191502,77	866846,21	18625,55	3751,78
Dewatering Centrifuge	168,27	520,54	410,40	110,15	207,25	662,65	51,44	108,40
Screen (1mm)	6016,91	393,01	361,82	31,19	442,07	814,71	85,24	13,82
ANA-1	2966,58	2071,98	1712,13	359,84	990,76	2488,90	178,32	93,02
ANOX-1	6914,92	3835,93	3008,03	827,91	1581,75	4234,34	274,65	174,49
AT-1A	6856,55	5164,60	3998,26	1166,34	2067,40	5608,86	358,55	235,71
AT-1B	6856,55	5162,92	3980,26	1182,66	2047,91	5580,93	357,65	235,71
Collect Distribute	27426,20	5162,09	3977,57	1184,52	2044,42	5575,98	356,12	235,71
MBR-A	1943,43	0	0	0	1,08	30,54	10,68	0,05
EFF Storage	5841,91	0	0	0	1,08	30,54	10,66	0,05
EFF	5841,91	0,00	0,00	0,00	1,08	30,54	10,66	0,05
RAS Pit	5790,91	10320,78	7933,55	2387,23	4047,33	11085,87	699,13	473,44
WAS Tank	175,00	9965,35	7847,36	2118,00	3940,40	11041,90	693,91	473,44
DEWATERED SLUDGE	7,38	225593,69	177857,38	47736,31	89698,79	248416,64	15287,28	8757,93
FeCl3	0	0	0	0	0	0	0	0
POLYMER	0,65	12197,85	12120,00	77,85	10830,31	18180,00	0	0

Album page - Concentration

Elements	INF (including Mugeba)	GRIT	Dewatering Centrifuge	SCREENING	ANA-1	ANOX-1	AT-1B	Collect Distribute	EFF	RAS Pit	DEWATERED SLUDGE

Flow [m3/d]	5849,40	0,29	168,27	0,47	2966,58	6914,92	6856,55	27426,20	5841,91	5790,91	7,38
Total suspended solids [mg/L]	444,21	28784,65	520,54	668458,45	2071,98	3835,93	5162,92	5162,09	0,00	10320,78	225593,69
Volatile suspended solids [mg/L]	412,21	824,28	410,40	647351,78	1712,13	3008,03	3980,26	3977,57	0,00	7933,55	177857,38
ISS Total [mg/L]	32,00	27960,37	110,15	21106,68	359,84	827,91	1182,66	1184,52	0,00	2387,23	47736,31
BOD - Total Carbonaceous [mg/L]	464,13	764,26	207,25	191502,77	990,76	1581,75	2047,91	2044,42	1,08	4047,33	89698,79
BOD - Filtered Carbonaceous [mg/L]	163,90	163,90	0,28	159,33	28,09	0,64	1,17	0,51	1,08	0,34	0,28
COD - Total [mg/L]	888,40	1487,35	662,65	866846,21	2488,90	4234,34	5580,93	5575,98	30,54	11085,87	248416,64
COD - Particulate [mg/L]	599,14	1198,09	573,00	866562,53	2410,54	4204,45	5550,63	5546,54	0,00	11056,12	248326,99
COD - Filtered [mg/L]	289,26	289,26	89,65	283,68	78,37	29,89	30,30	29,44	30,54	29,75	89,65
N - Total N [mgN/L]	87,70	94,39	51,44	18625,55	178,32	274,65	357,65	356,12	10,66	699,13	15287,28
N - Total Kjeldahl Nitrogen [mgN/L]	87,20	93,89	51,44	18625,06	178,32	274,56	347,17	346,97	1,66	694,03	15287,27
N - Particulate TKN [mgN/L]	6,70	13,39	35,24	18546,36	128,02	252,34	344,70	344,77	0,00	692,35	15271,07
N - Ammonia [mgN/L]	67,40	67,40	14,59	65,92	48,45	21,01	0,90	0,78	0,05	0,29	14,59
N - Nitrate [mgN/L]	0,50	0,50	0,00	0,49	0,00	0,07	7,60	6,44	8,93	4,97	0,00
N - Nitrite [mgN/L]	0	0,00	0,00	0,00	0,00	0,02	2,88	2,70	0,07	0,13	0,00
P - Total P [mgP/L]	11,40	16,50	108,40	3751,78	93,02	174,49	235,71	235,71	0,05	473,44	8757,93
P - Soluble PO4-P [mgP/L]	6,30	6,30	88,40	8,60	35,68	16,88	1,62	0,98	0,05	0,05	88,40



Album page - Conversions

Elements	Nit - Ammonia removal rate [kg/d]	Denit - Nitrate removal rate [kg/d]	OTR [kg/d]	OUR - Carbonaceous [kg/d]	OUR - Nitrification [kg/d]	OUR - Sulfur [kg/d]	OUR - Total [kg/d]	SOTR [kg/d]
ANA-1	0,00	0,83	0	0,00	0,00	0,00	0,00	0
ANA-2	0,00	0,83	0	0,00	0,00	0,00	0,00	0
ANA-3	0,00	0,83	0	0,00	0,00	0,00	0,00	0
ANA-4	0,00	0,83	0	0,00	0,00	0,00	0,00	0
ANOX-1	0,01	24,98	0	0,03	0,03	0,08	0,13	0
ANOX-2	0,01	24,98	0	0,03	0,03	0,08	0,13	0
ANOX-3	0,01	24,98	0	0,03	0,03	0,08	0,13	0
ANOX-4	0,01	24,98	0	0,03	0,03	0,08	0,13	0
AT-1A	51,16	14,94	406,24	156,38	192,29	54,17	402,84	1007,53
AT-1B	40,93	5,29	391,72	186,14	174,71	20,58	381,43	1172,66
AT-2A	51,16	14,94	406,24	156,38	192,29	54,17	402,84	1007,53
AT-2B	40,93	5,29	391,72	186,14	174,71	20,58	381,43	1172,66
AT-3A	51,16	14,94	406,24	156,38	192,29	54,17	402,84	1007,53
AT-3B	40,93	5,29	391,72	186,14	174,71	20,58	381,43	1172,66
AT-4A	51,16	14,94	406,24	156,38	192,29	54,17	402,84	1007,53
AT-4B	40,93	5,29	391,72	186,14	174,71	20,58	381,43	1172,66
Collect Distribute	5,68	35,14	0	25,71	22,08	6,13	53,92	0
MBR-A	4,22	2,74	166,70	123,40	27,07	4,80	155,27	667,64
MBR-B	4,22	2,86	165,80	123,01	27,06	4,80	154,87	651,46
MBR-C	4,23	2,88	166,18	123,33	27,14	4,81	155,29	651,46
RAS Pit	1,62	23,92	0	9,30	6,32	1,02	16,63	0
WAS Tank	0,00	0,87	0	0,00	0,00	0,00	0,00	0
	-----	-----	-----	-----	-----	-----	-----	-----
Total	388,35	252,58	3690,49	1774,97	1577,77	320,85	3673,60	10691,33

Global Parameters

Common

Name	Default	Value
Hydrolysis rate [1/d]	2,1000	2,1000 1,0290
Hydrolysis half sat. [-]	0,0600	0,0600 1,0000
Anoxic hydrolysis factor [-]	0,2800	0,2800 1,0000

Anaerobic hydrolysis factor (AS) [-]	0,0400	0,0400	1,0000
Anaerobic hydrolysis factor (AD) [-]	0,5000	0,5000	1,0000
Adsorption rate of colloids [L/(mgCOD d)]	0,1500	0,1500	1,0290
Ammonification rate [L/(mgCOD d)]	0,0800	0,0800	1,0290
Assimilative nitrate/nitrite reduction rate [1/d]	0,5000	0,5000	1,0000
Endogenous products decay rate [1/d]	0	0	1,0000

Ammonia oxidizing

Name	Default	Value	
Max. spec. growth rate [1/d]	0,9000	0,9000	1,0720
Substrate (NH ₄) half sat. [mgN/L]	0,7000	0,7000	1,0000
Byproduct NH ₄ logistic slope [-]	50,0000	50,0000	1,0000
Byproduct NH ₄ inflection point [mgN/L]	1,4000	1,4000	1,0000
Denite DO half sat. [mg/L]	0,1000	0,1000	1,0000
Denite HNO ₂ half sat. [mgN/L]	5,000E-6	5,000E-6	1,0000
Aerobic decay rate [1/d]	0,1700	0,1700	1,0290
Anoxic/anaerobic decay rate [1/d]	0,0800	0,0800	1,0290
KiHNO ₂ [mmol/L]	5,000E-3	5,000E-3	1,0000

Nitrite oxidizing

Name	Default	Value	
Max. spec. growth rate [1/d]	0,7000	0,7000	1,0600
Substrate (NO ₂) half sat. [mgN/L]	0,1000	0,1000	1,0000
Aerobic decay rate [1/d]	0,1700	0,1700	1,0290
Anoxic/anaerobic decay rate [1/d]	0,0800	0,0800	1,0290
KiNH ₃ [mmol/L]	0,0750	0,0750	1,0000

Anaerobic ammonia oxidizing

Name	Default	Value	
Max. spec. growth rate [1/d]	0,2000	0,2000	1,1000
Substrate (NH ₄) half sat. [mgN/L]	2,0000	2,0000	1,0000



Substrate (NO2) half sat. [mgN/L]	1,0000	1,0000	1,0000
Aerobic decay rate [1/d]	0,0190	0,0190	1,0290
Anoxic/anaerobic decay rate [1/d]	9,500E-3	9,500E-3	1,0290
Ki Nitrite [mgN/L]	1000,0000	1000,0000	1,0000
Nitrite sensitivity constant [L / (d mgN)]	0,0160	0,0160	1,0000

Ordinary heterotrophic

Name	Default	Value	
Max. spec. growth rate [1/d]	3,2000	3,2000	1,0290
Substrate half sat. [mgCOD/L]	5,0000	5,0000	1,0000
Anoxic growth factor [-]	0,5000	0,8000	1,0000
Denite N2 producers (NO3 or NO2) [-]	0,5000	0,5000	1,0000
Aerobic decay rate [1/d]	0,6200	0,6200	1,0290
Anoxic decay rate [1/d]	0,2330	0,2330	1,0290
Anaerobic decay rate [1/d]	0,1310	0,1310	1,0290
Fermentation rate [1/d]	1,6000	1,6000	1,0290
Fermentation half sat. [mgCOD/L]	5,0000	5,0000	1,0000
Fermentation growth factor (AS) [-]	0,2500	0,2500	1,0000
Free nitrous acid inhibition [mol/L]	1,000E-7	1,000E-7	1,0000

Heterotrophic on industrial COD

Name	Default	Value	
Maximum specific growth rate on Ind #1 COD [1/d]	4,3000	4,3000	1,0290
Substrate (Ind #1) half sat. [mgCOD/L]	1,0000	1,0000	1,0000
Inhibition coefficient for Ind #1 [mgCOD/L]	60,0000	60,0000	1,0000
Anaerobic growth factor for Ind #1 [mgCOD/L]	0,0500	0,0500	1,0000
Maximum specific growth rate on Ind #2 COD [1/d]	1,5000	1,5000	1,0290
Substrate (Ind #2) half sat. [mgCOD/L]	30,0000	30,0000	1,0000
Inhibition coefficient for Ind #2 [mgCOD/L]	3000,0000	3000,0000	1,0000
Anaerobic growth factor for Ind #2 [mgCOD/L]	0,0500	0,0500	1,0000
Maximum specific growth rate on Ind #3 COD [1/d]	4,3000	4,3000	1,0290
Substrate (Ind #3) half sat. [mgCOD/L]	1,0000	1,0000	1,0000
Inhibition coefficient for Ind #3 COD [mgCOD/L]	60,0000	60,0000	1,0000
Anaerobic growth factor for Ind #3 [mgCOD/L]	0,0500	0,0500	1,0000



Maximum specific growth rate on adsorbed hydrocarbon COD [1/d]	2,0000	2,0000	1,0290
Substrate (adsorbed hydrocarbon) half sat. [-]	0,1500	0,1500	1,0000
Anaerobic growth factor for adsorbed hydrocarbons [mgCOD/L]	0,0100	0,0100	1,0000
Adsorption rate of soluble hydrocarbons [l/(mgCOD d)]	0,2000	0,2000	1,0000

Methylotrophic

Name	Default	Value	
Max. spec. growth rate [1/d]	1,3000	1,3000	1,0720
Methanol half sat. [mgCOD/L]	0,5000	0,5000	1,0000
Denite N2 producers (NO3 or NO2) [-]	0,5000	0,5000	1,0000
Aerobic decay rate [1/d]	0,0400	0,0400	1,0290
Anoxic/anaerobic decay rate [1/d]	0,0300	0,0300	1,0290
Free nitrous acid inhibition [mmol/L]	1,000E-7	1,000E-7	1,0000

Phosphorus accumulating

Name	Default	Value	
Max. spec. growth rate [1/d]	0,9500	0,9500	1,0000
Max. spec. growth rate, P-limited [1/d]	0,4200	0,4200	1,0000
Substrate half sat. [mgCOD(PHB)/mgCOD(Zbp)]	0,1000	0,1000	1,0000
Substrate half sat., P-limited [mgCOD(PHB)/mgCOD(Zbp)]	0,0500	0,0500	1,0000
Magnesium half sat. [mgMg/L]	0,1000	0,1000	1,0000
Cation half sat. [mmol/L]	0,1000	0,1000	1,0000
Calcium half sat. [mgCa/L]	0,1000	0,1000	1,0000
Aerobic/anoxic decay rate [1/d]	0,1000	0,1000	1,0000
Aerobic/anoxic maintenance rate [1/d]	0	0	1,0000
Anaerobic decay rate [1/d]	0,0400	0,0400	1,0000
Anaerobic maintenance rate [1/d]	0	0	1,0000
Sequestration rate [1/d]	4,5000	4,5000	1,0000
Anoxic growth factor [-]	0,3300	0,3300	1,0000

Propionic acetogenic



Name	Default	Value	
Max. spec. growth rate [1/d]	0,2500	0,2500	1,0290
Substrate half sat. [mgCOD/L]	10,0000	10,0000	1,0000
Acetate inhibition [mgCOD/L]	10000,0000	10000,0000	1,0000
Anaerobic decay rate [1/d]	0,0500	0,0500	1,0290
Aerobic/anoxic decay rate [1/d]	0,5200	0,5200	1,0290

Methanogenic

Name	Default	Value	
Acetoclastic max. spec. growth rate [1/d]	0,3000	0,3000	1,0290
H2-utilizing max. spec. growth rate [1/d]	1,4000	1,4000	1,0290
Acetoclastic substrate half sat. [mgCOD/L]	100,0000	100,0000	1,0000
Acetoclastic methanol half sat. [mgCOD/L]	0,5000	0,5000	1,0000
H2-utilizing CO2 half sat. [mmol/L]	0,1000	0,1000	1,0000
H2-utilizing substrate half sat. [mgCOD/L]	1,0000	1,0000	1,0000
H2-utilizing methanol half sat. [mgCOD/L]	0,5000	0,5000	1,0000
Acetoclastic propionic inhibition [mgCOD/L]	10000,0000	10000,0000	1,0000
Acetoclastic anaerobic decay rate [1/d]	0,1300	0,1300	1,0290
Acetoclastic aerobic/anoxic decay rate [1/d]	0,6000	0,6000	1,0290
H2-utilizing anaerobic decay rate [1/d]	0,1300	0,1300	1,0290
H2-utilizing aerobic/anoxic decay rate [1/d]	2,8000	2,8000	1,0290

Sulfur oxidizing

Name	Default	Value	
Maximum specific growth rate (sulfide) [1/d]	0,7500	0,7500	1,0290
Maximum specific growth rate (sulfur) [1/d]	0,1000	0,1000	1,0290
Substrate (H2S) half sat. [mgS/L]	1,0000	1,0000	1,0000
Substrate (sulfur) half sat. [mgS/L]	1,0000	1,0000	1,0000
Anoxic growth factor [-]	0,5000	0,5000	1,0000
Decay rate [1/d]	0,0400	0,0400	1,0290

Sulfur reducing



Name	Default	Value	
Propionic max. spec. growth rate [1/d]	0,5830	0,5830	1,0350
Propionic acid half sat. [mgCOD/L]	295,0000	295,0000	1,0000
Hydrogen sulfide inhibition coefficient [mgS/L]	185,0000	185,0000	1,0000
Sulfate (SO4=) half sat. [mgS/L]	2,4700	2,4700	1,0000
Decay rate [1/d]	0,0185	0,0185	1,0350
Acetotrophic max. spec. growth rate [1/d]	0,6120	0,6120	1,0350
Acetic acid half sat. [mgCOD/L]	24,0000	24,0000	1,0000
Hydrogen sulfide inhibition coefficient [mgS/L]	164,0000	164,0000	1,0000
Sulfate (SO4=) half sat. [mgS/L]	6,4100	6,4100	1,0000
Decay rate [1/d]	0,0275	0,0275	1,0350
Hydrogenotrophic max. spec. growth rate with SO4= [1/d]	2,8000	2,8000	1,0350
Hydrogenotrophic max. spec. growth rate with S [1/d]	0,1000	0,1000	1,0350
Hydrogen half sat. [mgCOD/L]	0,0700	0,0700	1,0000
Hydrogen sulfide inhibition coefficient [mgS/L]	550,0000	550,0000	1,0000
Sulfate (SO4=) half sat. [mgS/L]	6,4100	6,4100	1,0000
Sulfur (S) half sat. [mgS/L]	50,0000	50,0000	1,0000
Decay rate [1/d]	0,0600	0,0600	1,0350

pH

Name	Default	Value
Ordinary heterotrophic low pH limit [-]	4,0000	4,0000
Ordinary heterotrophic high pH limit [-]	10,0000	10,0000
Methylotrophic low pH limit [-]	4,0000	4,0000
Methylotrophic high pH limit [-]	10,0000	10,0000
Autotrophic low pH limit [-]	5,5000	5,5000
Autotrophic high pH limit [-]	9,5000	9,5000
Phosphorus accumulating low pH limit [-]	4,0000	4,0000
Phosphorus accumulating high pH limit [-]	10,0000	10,0000
Ordinary heterotrophic low pH limit (anaerobic) [-]	5,5000	5,5000
Ordinary heterotrophic high pH limit (anaerobic) [-]	8,5000	8,5000
Propionic acetogenic low pH limit [-]	4,0000	4,0000
Propionic acetogenic high pH limit [-]	10,0000	10,0000
Acetoclastic methanogenic low pH limit [-]	5,0000	5,0000
Acetoclastic methanogenic high pH limit [-]	9,0000	9,0000
H2-utilizing methanogenic low pH limit [-]	5,0000	5,0000
H2-utilizing methanogenic high pH limit [-]	9,0000	9,0000

Switches

Name	Default	Value
Ordinary heterotrophic DO half sat. [mgO2/L]	0,1500	0,1500
Phosphorus accumulating DO half sat. [mgO2/L]	0,0500	0,0500
Anoxic/anaerobic NOx half sat. [mgN/L]	0,1500	0,1500
Ammonia oxidizing DO half sat. [mgO2/L]	0,2500	0,2500
Nitrite oxidizing DO half sat. [mgO2/L]	0,5000	0,5000
Anaerobic ammonia oxidizing DO half sat. [mgO2/L]	0,0100	0,0100
Sulfur oxidizing sulfate pathway DO half sat. [mgO2/L]	0,2500	0,2500
Sulfur oxidizing sulfur pathway DO half sat. [mgO2/L]	0,0500	0,0500
Anoxic NO3(->NO2) half sat. [mgN/L]	0,1000	0,1000
Anoxic NO3(->N2) half sat. [mgN/L]	0,0500	0,0500
Anoxic NO2(->N2) half sat. (mgN/L)	0,0100	0,0100
NH3 nutrient half sat. [mgN/L]	5,000E-3	5,000E-3
PolyP half sat. [mgP/mgCOD]	0,0100	0,0100
VFA sequestration half sat. [mgCOD/L]	5,0000	5,0000
P uptake half sat. [mgP/L]	0,1500	0,1500
P nutrient half sat. [mgP/L]	1,000E-3	1,000E-3
Autotrophic CO2 half sat. [mmol/L]	0,1000	0,1000
H2 low/high half sat. [mgCOD/L]	1,0000	1,0000
Propionic acetogenic H2 inhibition [mgCOD/L]	5,0000	5,0000
Synthesis anion/cation half sat. [meq/L]	0,0100	0,0100

Common

Name	Default	Value
Biomass/Endog Ca content (gCa/gCOD)	3,912E-3	3,912E-3
Biomass/Endog Mg content (gMg/gCOD)	3,912E-3	3,912E-3
Biomass/Endog other cations content (mol/gCOD)	5,115E-4	5,115E-4
Biomass/Endog other Anions content (mol/gCOD)	1,410E-4	1,410E-4
N in endogenous residue [mgN/mgCOD]	0,0700	0,0700
P in endogenous residue [mgP/mgCOD]	0,0220	0,0220
Ca content of slowly biodegradable (gCa/gCOD)	3,912E-3	3,912E-3
Mg content of slowly biodegradable (gMg/gCOD)	3,700E-4	3,700E-4
Endogenous residue COD:VSS ratio [mgCOD/mgVSS]	1,4200	1,4200
Particulate substrate COD:VSS ratio [mgCOD/mgVSS]	1,6327	1,5000

Particulate inert COD:VSS ratio [mgCOD/mgVSS]	1,6000	1,1000
Cellulose COD:VSS ratio [mgCOD/mgVSS]	1,4000	1,4000
External organic COD:VSS ratio [mgCOD/mgVSS]	1,6000	1,6000
Molecular weight of other anions [mg/mmol]	35,5000	35,5000
Molecular weight of other cations [mg/mmol]	39,0983	39,0983

Ammonia oxidizing

Name	Default	Value
Yield [mgCOD/mgN]	0,1500	0,1500
Denite NO2 fraction as TEA [-]	0,5000	0,5000
Byproduct NH4 fraction to N2O [-]	2,500E-3	2,500E-3
N in biomass [mgN/mgCOD]	0,0700	0,0700
P in biomass [mgP/mgCOD]	0,0220	0,0220
Fraction to endogenous residue [-]	0,0800	0,0800
COD:VSS ratio [mgCOD/mgVSS]	1,4200	1,4200

Nitrite oxidizing

Name	Default	Value
Yield [mgCOD/mgN]	0,0900	0,0900
N in biomass [mgN/mgCOD]	0,0700	0,0700
P in biomass [mgP/mgCOD]	0,0220	0,0220
Fraction to endogenous residue [-]	0,0800	0,0800
COD:VSS ratio [mgCOD/mgVSS]	1,4200	1,4200

Anaerobic ammonia oxidizing

Name	Default	Value
Yield [mgCOD/mgN]	0,1140	0,1140
Nitrate production [mgN/mgBiomassCOD]	2,2800	2,2800
N in biomass [mgN/mgCOD]	0,0700	0,0700
P in biomass [mgP/mgCOD]	0,0220	0,0220
Fraction to endogenous residue [-]	0,0800	0,0800



COD:VSS ratio [mgCOD/mgVSS]	1,4200	1,4200
-----------------------------	--------	--------

Ordinary heterotrophic

Name	Default	Value
Yield (aerobic) [-]	0,6660	0,6660
Yield (fermentation, low H2) [-]	0,1000	0,1000
Yield (fermentation, high H2) [-]	0,1000	0,1000
H2 yield (fermentation low H2) [-]	0,3500	0,3500
H2 yield (fermentation high H2) [-]	0	0
Propionate yield (fermentation, low H2) [-]	0	0
Propionate yield (fermentation, high H2) [-]	0,7000	0,7000
CO2 yield (fermentation, low H2) [-]	0,7000	0,7000
CO2 yield (fermentation, high H2) [-]	0	0
N in biomass [mgN/mgCOD]	0,0700	0,0700
P in biomass [mgP/mgCOD]	0,0220	0,0220
Endogenous fraction - aerobic [-]	0,0800	0,0800
Endogenous fraction - anoxic [-]	0,1030	0,1030
Endogenous fraction - anaerobic [-]	0,1840	0,1840
COD:VSS ratio [mgCOD/mgVSS]	1,4200	1,4200
Yield (anoxic) [-]	0,5400	0,5400
Yield propionic (aerobic) [-]	0,6400	0,6400
Yield propionic (anoxic) [-]	0,4600	0,4600
Yield acetic (aerobic) [-]	0,6000	0,6000
Yield acetic (anoxic) [-]	0,4300	0,4300
Yield methanol (aerobic) [-]	0,5000	0,5000
Adsorp. max. [-]	1,0000	1,0000
Max fraction to N2O at high FNA over nitrate [-]	0,0500	0,0500
Max fraction to N2O at high FNA over nitrite [-]	0,1000	0,1000

Ordinary heterotrophic on industrial COD

Name	Default	Value
Yield Ind #1 COD (Aerobic) [-]	0,5000	0,5000
Yield Ind #1 COD (Anoxic) [-]	0,4000	0,4000
Yield Ind #1 COD (Anaerobic) [-]	0,0400	0,0400

COD:Mole ratio - Ind #1 COD [gCOD/Mol]	224,0000	224,0000
Yield Ind #2 COD (Aerobic) [-]	0,5000	0,5000
Yield Ind #2 COD (Anoxic) [-]	0,4000	0,4000
Yield Ind #2 COD (Anaerobic) [-]	0,0500	0,0500
COD:Mole ratio - Ind #2 COD [gCOD/Mol]	240,0000	240,0000
Yield on Ind #3 COD (Aerobic) [-]	0,5000	0,5000
Yield on Ind #3 COD (Anoxic) [-]	0,4000	0,4000
Yield on Ind #3 COD (Anaerobic) [-]	0,0400	0,0400
COD:Mole ratio - Ind #3 COD [gCOD/Mol]	288,0000	288,0000
Yield enmeshed hydrocarbons (Aerobic) [-]	0,5000	0,5000
Yield enmeshed hydrocarbons (Anoxic) [-]	0,4000	0,4000
Yield enmeshed hydrocarbons (Anaerobic) [-]	0,0400	0,0400
COD:Mole ratio - Hydrocarbon COD [gCOD/Mol]	336,0000	336,0000
Hydrocarbon COD:VSS ratio [mgCOD/mgVSS]	3,2000	3,2000
Max. hydrocarbon adsorp. ratio [-]	1,0000	1,0000
Yield of Ind #1 on Ind #3 COD (Aerobic) [-]	0	0
Yield of Ind #1 on Ind #3 COD (Anoxic) [-]	0	0
Hydrocarbon Yield on Ind #3 COD (Aerobic) [-]	0	0
Hydrocarbon Yield on Ind #3 COD (Anoxic) [-]	0	0

Methylotrophic

Name	Default	Value
Yield (anoxic) [-]	0,4000	0,4000
N in biomass [mgN/mgCOD]	0,0700	0,0700
P in biomass [mgP/mgCOD]	0,0220	0,0220
Fraction to endogenous residue [-]	0,0800	0,0800
COD:VSS ratio [mgCOD/mgVSS]	1,4200	1,4200
Max fraction to N ₂ O at high FNA over nitrate [-]	0,1000	0,1000
Max fraction to N ₂ O at high FNA over nitrite [-]	0,1500	0,1500

Phosphorus accumulating

Name	Default	Value
Yield (aerobic) [-]	0,6390	0,6390
Yield (anoxic) [-]	0,5200	0,5200

Aerobic P/PHA uptake [mgP/mgCOD]	0,9300	0,9300
Anoxic P/PHA uptake [mgP/mgCOD]	0,3500	0,3500
Yield of PHA on sequestration [-]	0,8890	0,8890
N in biomass [mgN/mgCOD]	0,0700	0,0700
N in sol. inert [mgN/mgCOD]	0,0700	0,0700
P in biomass [mgP/mgCOD]	0,0220	0,0220
Fraction to endogenous part. [-]	0,2500	0,2500
Inert fraction of endogenous sol. [-]	0,2000	0,2000
P/Ac release ratio [mgP/mgCOD]	0,5100	0,5100
COD:VSS ratio [mgCOD/mgVSS]	1,4200	1,4200
Yield of low PP [-]	0,9400	0,9400
Mg to P mole ratio in polyphosphate [mmolMg/mmolP]	0,3000	0,3000
Cation to P mole ratio in polyphosphate [meq/mmolP]	0,1500	0,1500
Ca to P mole ratio in polyphosphate [mmolCa/mmolP]	0,0500	0,0500

Propionic acetogenic

Name	Default	Value
Yield [-]	0,1000	0,1000
H ₂ yield [-]	0,4000	0,4000
CO ₂ yield [-]	1,0000	1,0000
N in biomass [mgN/mgCOD]	0,0700	0,0700
P in biomass [mgP/mgCOD]	0,0220	0,0220
Fraction to endogenous residue [-]	0,0800	0,0800
COD:VSS ratio [mgCOD/mgVSS]	1,4200	1,4200

Methanogenic

Name	Default	Value
Acetoclastic yield [-]	0,1000	0,1000
Acetoclastic yield on methanol[-]	0,1000	0,1000
H ₂ -utilizing yield [-]	0,1000	0,1000
H ₂ -utilizing yield on methanol [-]	0,1000	0,1000
N in acetoclastic biomass [mgN/mgCOD]	0,0700	0,0700
N in H ₂ -utilizing biomass [mgN/mgCOD]	0,0700	0,0700
P in acetoclastic biomass [mgP/mgCOD]	0,0220	0,0220



P in H2-utilizing biomass [mgP/mgCOD]	0,0220	0,0220
Acetoclastic fraction to endog. residue [-]	0,0800	0,0800
H2-utilizing fraction to endog. residue [-]	0,0800	0,0800
Acetoclastic COD:VSS ratio [mgCOD/mgVSS]	1,4200	1,4200
H2-utilizing COD:VSS ratio [mgCOD/mgVSS]	1,4200	1,4200

Sulfur oxidizing

Name	Default	Value
Yield (aerobic) [mgCOD/mgS]	0,5000	0,5000
Yield (Anoxic) [mgCOD/mgS]	0,3500	0,3500
N in biomass [mgN/mgCOD]	0,0700	0,0700
P in biomass [mgP/mgCOD]	0,0220	0,0220
Fraction to endogenous residue [-]	0,0800	0,0800
COD:VSS ratio [mgCOD/mgVSS]	1,4200	1,4200

Sulfur reducing

Name	Default	Value
Yield [mgCOD/mg H2 COD]	0,0712	0,0712
Yield [mgCOD/mg Ac COD]	0,0470	0,0470
Yield [mgCOD/mg Pr COD]	0,0384	0,0384
N in biomass [mgN/mgCOD]	0,0700	0,0700
P in biomass [mgP/mgCOD]	0,0220	0,0220
Fraction to endogenous residue [-]	0,0800	0,0800
COD:VSS ratio [mgCOD/mgVSS]	1,4200	1,4200

General

Name	Default	Value
Tank head loss per metre of length (from flow) [m/m]	2,500E-3	2,500E-3
BOD calculation rate constant for Xsc degradation [1/d]	0,5000	0,1395
BOD calculation rate constant for Xsp (and hydrocarbon) degradation [1/d]	0,5000	0,5814
BOD calculation rate constant for Xeo degradation [1/d]	0,5000	0,5000



Heating fuel/Chemical Costs

Name	Default	Value
Methanol [€/L]	0,3884	0,3884
Ferric [€/L]	0,0883	0,0883
Ferrous [€/L]	0,0883	0,0883
Aluminium [€/L]	0,0706	0,0706
Natural gas [€/GJ]	2,6480	2,6480
Heating oil [€/L]	0,4413	0,4413
Diesel [€/L]	0,6179	0,6179
Custom fuel [€/L]	0,8827	0,8827
Biogas sale price [€/GJ]	1,7653	1,7653

Anaerobic digester

Name	Default	Value
Bubble rise velocity (anaerobic digester) [cm/s]	23,9000	23,9000
Bubble Sauter mean diameter (anaerobic digester) [cm]	0,3500	0,3500
Anaerobic digester gas hold-up factor []	1,0000	1,0000

Combined Heat and Power (CHP) engine

Name	Default	Value
Methane heat of combustion [kJ/mole]	800,0000	800,0000
Hydrogen heat of combustion [kJ/mole]	240,0000	240,0000
CHP engine heat price [€/kWh]	0	0
CHP engine power price [€/kWh]	0,1324	0,1324

Calorific values of heating fuels

Name	Default	Value
------	---------	-------



Calorific value of natural gas [kJ/kg]	48000	48000
Calorific value of heating fuel oil [kJ/kg]	42000	42000
Calorific value of diesel [kJ/kg]	46000	46000
Calorific value of custom fuel [kJ/kg]	32000	32000

Density of liquid heating fuels

Name	Default	Value
Density of heating fuel oil [kg/m ³]	900	900
Density of diesel [kg/m ³]	875	875
Density of custom fuel [kg/m ³]	790	790

Mass transfer

Name	Default	Value
KI for H2 [m/d]	17,0000	17,0000 1,0240
KI for CO2 [m/d]	10,0000	10,0000 1,0240
KI for NH3 [m/d]	1,0000	1,0000 1,0240
KI for CH4 [m/d]	8,0000	8,0000 1,0240
KI for N2 [m/d]	15,0000	15,0000 1,0240
KI for N2O [m/d]	8,0000	8,0000 1,0240
KI for H2S [m/d]	1,0000	1,0000 1,0240
KI for Ind #1 COD [m/d]	0	0 1,0240
KI for Ind #2 COD [m/d]	0,5000	0,5000 1,0240
KI for Ind #3 COD [m/d]	0	0 1,0240
KI for O2 [m/d]	13,0000	13,0000 1,0240

Henry's law constants

Name	Default	Value
CO2 [M/atm]	3,4000E-2	3,4000E-2 2400,0000
O2 [M/atm]	1,3000E-3	1,3000E-3 1500,0000
N2 [M/atm]	6,5000E-4	6,5000E-4 1300,0000
N2O [M/atm]	2,5000E-2	2,5000E-2 2600,0000

NH3 [M/atm]	5,8000E+1	5,8000E+1	4100,0000
CH4 [M/atm]	1,4000E-3	1,4000E-3	1600,0000
H2 [M/atm]	7,8000E-4	7,8000E-4	500,0000
H2S [M/Atm]	1,0000E-1	1,0000E-1	2200,0000
Ind 1 [M/Atm]	1,9000E+3	1,9000E+3	7300,0000
Ind 2 [M/Atm]	1,8000E-1	1,8000E-1	2200,0000
Ind 3 [M/Atm]	1,5000E-1	1,5000E-1	1900,0000

Properties constants

Name	Default	Value
K in Viscosity = $K e^{-(Ea/RT)}$ [Pa s]	6,849E-7	6,849E-7
Ea in Viscosity = $K e^{-(Ea/RT)}$ [j/mol]	1,780E+4	1,780E+4
Y in ML Viscosity = H2O viscosity * (1+A*MLSS^Y) [-]	1,0000	1,0000
A in ML Viscosity = H2O viscosity * (1+A*MLSS^Y) [m3/g]	1,000E-7	1,000E-7
A in ML Density = H2O density + A*MLSS [(kg/m3)/(g/m3)]	3,248E-4	3,248E-4
A in Antoine equn. [T in K, P in Bar {NIST}]	5,2000	5,2000
B in Antoine equn. [T in K, P in Bar {NIST}]	1734,0000	1734,0000
C in Antoine equn. [T in K, P in Bar {NIST}]	-39,5000	-39,5000

Metal salt solution densities

Name	Default	Value
Ferric chloride solution density [kg/m3]	3820,0000	3820,0000
Ferrous chloride solution density [kg/m3]	3160,0000	3160,0000
Aluminium sulfate solution density [kg/m3]	1950,0000	1950,0000

Mineral precipitation rates

Name	Default	Value	
Vivianite precipitation rate [L/(mol d)]	1,000E+5	1,000E+5	1,0240
Vivianite redissolution rate [L/(mol d)]	1,000E+5	1,000E+5	1,0240
Vivianite half sat. [mgTSS/L]	0,0100	0,0100	1,0000
FeS precipitation rate [L/(mol d)]	1000,0000	1000,0000	1,0240



FeS redissolution rate [L/(mol d)]	10,0000	10,0000	1,0240
FeS half sat. [mgTSS/L]	0,1000	0,1000	1,0000
Struvite precipitation rate [L ² /(mol ² d)]	3,000E+10	3,000E+10	1,0240
Struvite redissolution rate [L ² /(mol ² d)]	3,000E+11	3,000E+11	1,0240
Struvite half sat. [mgTSS/L]	1,0000	1,0000	1,0000
Brushite precipitation rate [L/(mol d)]	1,000E+6	1,000E+6	1,0000
Brushite redissolution rate [L/(mol d)]	10000,0000	10000,0000	1,0000
Brushite half sat. [mgTSS/L]	1,0000	1,0000	1,0000
HAP precipitation rate [g/d]	5,000E-4	5,000E-4	1,0000

Mineral precipitation constants

Name	Default	Value
Vivianite solubility product [mol/L] ⁵	1,710E-36	1,710E-36
FeS solubility product [mol/L] ²	4,258E-4	4,258E-4
Struvite solubility product [mol/L] ³	6,918E-14	6,918E-14
Brushite solubility product [mol/L] ²	2,490E-7	2,490E-7

Fe rates

Name	Default	Value	
A in aging rate = $A \cdot \exp(-G/B)$ [1/d]	16,1550	16,1550	1,0000
B in aging rate = $A \cdot \exp(-G/B)$ [1/s]	57,3000	57,3000	1,0000
HFO(L) aging rate factor	2,500E-4	2,500E-4	1,0000
HFO(H) with H ₂ PO ₄ ⁻ bound aging factor []	1,000E-5	1,000E-5	1,0000
HFO(L) with H ₂ PO ₄ ⁻ bound aging factor []	0,4000	0,4000	1,0000
H ₂ PO ₄ ⁻ coprecipitation rate [mol/(L d)]	1,500E-9	1,500E-9	1,0000
H ₂ PO ₄ ⁻ Adsorption rate [mol/(L d)]	2,000E-11	2,000E-11	1,0000
H ⁺ competition for HFO(H) protonation sites [L/(mmol . d)]	1000,0000	1000,0000	1,0000
H ⁺ competition for HFO(L) protonation sites [L/(mmol . d)]	100,0000	100,0000	1,0000

Fe constants

Name	Default	Value
------	---------	-------



Ferric active site factor(high) [{mol Sites}/{mol HFO(H)}]	4,0000	4,0000
Ferric active site factor(low) [{mol Sites}/{mol HFO(L)}]	2,4000	2,4000
H+ competition level for Fe(OH)3 [mol/L]	7,000E-7	7,000E-7
Equilibrium constant for FeOH3-H2PO4- [{mf HFO(H).H2PO4-}/({mol H2PO4-}{mf HFO(H)}^2)]	2,000E-9	2,000E-9
Colloidal COD removed with Ferric [gCOD/Fe active site]	80,0000	80,0000
Minimum residual P level with iron addition [mgP/L]	0,0150	0,0150
HFO(H) with H2PO4- P release factor	10000,0000	10000,0000
HFO(L) with H2PO4- P release factor	10000,0000	10000,0000

Fe RedOx rates

Name	Default	Value	
Iron reduction using acetic acid	1,000E-7	1,000E-7	1,0000
Half Sat. acetic acid	0,5000	0,5000	1,0000
Iron reduction using propionic acid	1,000E-7	1,000E-7	1,0000
Half Sat. propionic acid	0,5000	0,5000	1,0000
Iron reduction using dissolved hydrogen gas	1,000E-7	1,000E-7	1,0000
Half Sat. dissolved hydrogen gas	0,5000	0,5000	1,0000
Iron reduction using hydrogen sulfide	5,000E-5	5,000E-5	1,0000
Half Sat. hydrogen sulfide	0,5000	0,5000	1,0000
Iron oxidation rate (aerobic)	1,000E-3	1,000E-3	1,0000
Abiotic iron reduction using acetic acid	2,000E-5	2,000E-5	1,0000
Abiotic iron reduction using propionic acid	2,000E-5	2,000E-5	1,0000
Abiotic iron reduction using dissolved hydrogen gas	2,000E-5	2,000E-5	1,0000
Abiotic iron reduction using hydrogen sulfide	2,000E-5	2,000E-5	1,0000
Abiotic iron oxidation rate (aerobic)	1,0000	1,0000	1,0000

CEPT rates

Name	Default	Value	
HFO colloidal adsorption rate	1,0000	1,0000	1,0000
Residual Xsc for adsorption to HFO	5,0000	5,0000	1,0000
Slope for Xsc residual	1,0000	1,0000	1,0000
HAO colloidal adsorption rate	1,0000	1,0000	1,0000
Residual Xsc for adsorption to HAO	5,0000	5,0000	1,0000
Slope for Xsc residual	1,0000	1,0000	1,0000

Al rates

Name	Default	Value	
A in aging rate = $A * \exp(-G/B)$ [1/d]	16,1550	16,1550	1,0000
B in aging rate = $A * \exp(-G/B)$ [1/s]	57,3000	57,3000	1,0000
HAO(L) aging rate factor	2,500E-4	2,500E-4	1,0000
HAO(H) with H ₂ PO ₄ ⁻ bound aging factor []	1,000E-5	1,000E-5	1,0000
HAO(L) with H ₂ PO ₄ ⁻ bound aging factor []	0,4000	0,4000	1,0000
H ₂ PO ₄ ⁻ coprecipitation rate [mol/(L d)]	1,500E-9	1,500E-9	1,0000
H ₂ PO ₄ ⁻ Adsorption rate [mol/(L d)]	1,000E-9	1,000E-9	1,0000

Al constants

Name	Default	Value
Al active site factor(high) [{mol Sites}/{mol HAO(H)}]	3,0000	3,0000
Al active site factor(low) [{mol Sites}/{mol HAO(L)}]	1,5000	1,5000
Equilibrium constant for AlOH ₃ -H ₂ PO ₄ ⁻ [{mf HAO(H).H ₂ PO ₄ ⁻ }/{(mol H ₂ PO ₄ ⁻){mf HAO(H)} ²]	8,000E-10	8,000E-10
Colloidal COD removed with Al [gCOD/Al active site]	30,0000	30,0000
Minimum residual P level with Al addition [mgP/L]	0,0150	0,0150
HAO(H) with H ₂ PO ₄ ⁻ P release factor	10000,0000	10000,0000
HAO(L) with H ₂ PO ₄ ⁻ P release factor	10000,0000	10000,0000

Pipe and pump parameters

Name	Default	Value
Static head [m]	0,2500	0,2500
Pipe length (headloss calc.s) [m]	50,0000	50,0000
Pipe inside diameter [mm]	500,000	500,000
K(fittings) - Total minor losses K	5,0000	5,0000
Pipe roughness [mm]	0,200	0,200
'A' in overall pump efficiency = $A + B*Q + C*(Q^2)$ [-]	0,8500	0,8500
'B' in overall pump efficiency = $A + B*Q + C*(Q^2)$ [-]/(m ³ /d)]	0	0
'C' in overall pump efficiency = $A + B*Q + C*(Q^2)$ [-]/(m ³ /d) ²]	0	0



Fittings and loss coefficients ('K' values)

Name	Default	Value
Pipe entrance (bellmouth)	0,0500	1,0000
90° bend	0,7500	5,0000
45° bend	0,3000	2,0000
Butterfly valve (open)	0,3000	1,0000
Non-return valve	1,0000	0
Outlet (bellmouth)	0,2000	1,0000

Aeration

Name	Default	Value
Surface pressure [kPa]	101,3250	101,3250
Fractional effective saturation depth (Fed) [-]	0,3250	0,3250
Supply gas CO2 content [vol. %]	0,0400	0,0400
Supply gas O2 [vol. %]	20,9500	20,9500
Off-gas CO2 [vol. %]	2,0000	2,0000
Off-gas O2 [vol. %]	18,8000	18,8000
Off-gas H2 [vol. %]	0	0
Off-gas NH3 [vol. %]	0	0
Off-gas CH4 [vol. %]	0	0
Off-gas N2O [vol. %]	0	0
Surface turbulence factor [-]	2,0000	2,0000
Set point controller gain []	1,0000	1,0000

Blower

Name	Default	Value
Intake filter pressure drop [kPa]	3,5000	3,5000
Pressure drop through distribution system (piping/valves) [kPa]	3,0000	3,0000
Adiabatic/polytropic compression exponent (1.4 for adiabatic)	1,4000	1,4000
'A' in blower efficiency = $A + B \cdot Q_a + C \cdot (Q_a^2)$ [-]	0,7500	0,7500
'B' in blower efficiency = $A + B \cdot Q_a + C \cdot (Q_a^2)$ [-]/(m3/hr (20C, 1 atm))]	0	0
'C' in blower efficiency = $A + B \cdot Q_a + C \cdot (Q_a^2)$ [-]/(m3/hr (20C, 1 atm))^2]	0	0



Diffuser

Name	Default	Value
k_1 in $C = k_1(PC)^{0.25} + k_2$	1,2400	1,2400
k_2 in $C = k_1(PC)^{0.25} + k_2$	0,8960	0,8960
Y in $Kla = C U_{sg} \wedge Y - U_{sg}$ in [m ³ /(m ² d)]	0,8880	0,8880
Area of one diffuser [m ²]	0,0410	0,0380
Diffuser mounting height [m]	0,2500	0,2500
Min. air flow rate per diffuser m ³ /hr (20C, 1 atm)	0,5000	0,5000
Max. air flow rate per diffuser m ³ /hr (20C, 1 atm)	10,0000	10,0000
'A' in diffuser pressure drop = $A + B*(Qa/Diff) + C*(Qa/Diff)^2$ [kPa]	3,0000	3,0000
'B' in diffuser pressure drop = $A + B*(Qa/Diff) + C*(Qa/Diff)^2$ [kPa/(m ³ /hr (20C, 1 atm))]	0	0
'C' in diffuser pressure drop = $A + B*(Qa/Diff) + C*(Qa/Diff)^2$ [kPa/(m ³ /hr (20C, 1 atm))^2]	0	0

Surface aerators

Name	Default	Value
Surface aerator Std. oxygen transfer rate [kg O ₂ /(kW hr)]	1,50000	1,50000

Modified Vesilind

Name	Default	Value
Maximum Vesilind settling velocity (V_0) [m/d]	170,000	170,000
Vesilind hindered zone settling parameter (K) [L/g]	0,370	0,370
Clarification switching function [mg/L]	100,000	100,000
Specified TSS conc.for height calc. [mg/L]	2500,000	2500,000
Maximum compactability constant [mg/L]	15000,000	15000,000
Maximum compactability slope [L/mg]	0,010	0,010

Double exponential

Name	Default	Value
------	---------	-------



Maximum Vesilind settling velocity (Vo) [m/d]	410,000	410,000
Maximum (practical) settling velocity (Vo') [m/d]	270,000	270,000
Hindered zone settling parameter (Kh) [L/g]	0,400	0,400
Flocculent zone settling parameter (Kf) [L/g]	2,500	2,500
Maximum non-settleable TSS [mg/L]	20,0000	20,0000
Non-settleable fraction [-]	1,000E-3	1,000E-3
Specified TSS conc. for height calc. [mg/L]	2500,0000	2500,0000

Emission factors

Name	Default	Value
Carbon dioxide equivalence of nitrous oxide	296,0000	296,0000
Carbon dioxide equivalence of methane	23,0000	23,0000

Biofilm general

Name	Default	Value	
Attachment rate [g / (m2 d)]	8,0000	8,0000	1,0000
Attachment TSS half sat. [mg/L]	100,0000	100,0000	1,0000
Detachment rate [g/(m3 d)]	8000,0000	8000,0000	1,0000
Solids movement factor []	10,0000	10,0000	1,0000
Diffusion neta []	0,8000	0,8000	1,0000
Thin film limit [mm]	0,5000	0,5000	1,0000
Thick film limit [mm]	3,0000	3,0000	1,0000
Assumed Film thickness for tank volume correction (temp independent) [mm]	1,2500	1,2500	1,0000
Film surface area to media area ratio - Max.[]	1,0000	1,0000	1,0000
Minimum biofilm conc. for streamer formation [gTSS/m2]	4,0000	4,0000	1,0000

Maximum biofilm concentrations [mg/L]

Name	Default	Value	
Biomass - Ordinary heterotrophic	5,000E+4	5,000E+4	1,0000
Biomass - Methylotrophic	5,000E+4	5,000E+4	1,0000
Biomass - Ammonia oxidizing	1,000E+5	1,000E+5	1,0000



Biomass - Nitrite oxidizing	1,000E+5	1,000E+5	1,0000
Biomass - Anaerobic ammonia oxidizing	5,000E+4	5,000E+4	1,0000
Biomass - Phosphorus accumulating	5,000E+4	5,000E+4	1,0000
Biomass - Propionic acetogenic	5,000E+4	5,000E+4	1,0000
Biomass - Acetoclastic methanogenic	5,000E+4	5,000E+4	1,0000
Biomass - Hydrogenotrophic methanogenic	5,000E+4	5,000E+4	1,0000
Biomass - Endogenous products	3,000E+4	3,000E+4	1,0000
CODp - Slowly degradable particulate	5000,0000	5000,0000	1,0000
CODp - Slowly degradable colloidal	4000,0000	4000,0000	1,0000
CODp - Degradable external organics	5000,0000	5000,0000	1,0000
CODp - Undegradable non-cellulose	5000,0000	5000,0000	1,0000
CODp - Undegradable cellulose	5000,0000	5000,0000	1,0000
N - Particulate degradable organic	0	0	1,0000
P - Particulate degradable organic	0	0	1,0000
N - Particulate degradable external organics	0	0	1,0000
P - Particulate degradable external organics	0	0	1,0000
N - Particulate undegradable	0	0	1,0000
P - Particulate undegradable	0	0	1,0000
CODp - Stored PHA	5000,0000	5000,0000	1,0000
P - Releasable stored polyP	1,150E+6	1,150E+6	1,0000
P - Unreleasable stored polyP	1,150E+6	1,150E+6	1,0000
CODs - Complex readily degradable	0	0	1,0000
CODs - Acetate	0	0	1,0000
CODs - Propionate	0	0	1,0000
CODs - Methanol	0	0	1,0000
Gas - Dissolved hydrogen	0	0	1,0000
Gas - Dissolved methane	0	0	1,0000
N - Ammonia	0	0	1,0000
N - Soluble degradable organic	0	0	1,0000
Gas - Dissolved nitrous oxide	0	0	1,0000
N - Nitrite	0	0	1,0000
N - Nitrate	0	0	1,0000
Gas - Dissolved nitrogen	0	0	1,0000
P - Soluble phosphate	0	0	1,0000
CODs - Undegradable	0	0	1,0000
N - Soluble undegradable organic	0	0	1,0000
Influent inorganic suspended solids	1,300E+6	1,300E+6	1,0000
Precipitate - Struvite	8,500E+5	8,500E+5	1,0000
Precipitate - Brushite	1,165E+6	1,165E+6	1,0000
Precipitate - Hydroxy - apatite	1,600E+6	1,600E+6	1,0000
Precipitate - Vivianite	1,340E+6	1,340E+6	1,0000



HFO - High surface	5,000E+4	5,000E+4	1,0000
HFO - Low surface	5,000E+4	5,000E+4	1,0000
HFO - High with H2PO4- adsorbed	5,000E+4	5,000E+4	1,0000
HFO - Low with H2PO4- adsorbed	5,000E+4	5,000E+4	1,0000
HFO - Aged	5,000E+4	5,000E+4	1,0000
HFO - Low with H+ adsorbed	5,000E+4	5,000E+4	1,0000
HFO - High with H+ adsorbed	5,000E+4	5,000E+4	1,0000
HAO - High surface	5,000E+4	5,000E+4	1,0000
HAO - Low surface	5,000E+4	5,000E+4	1,0000
HAO - High with H2PO4- adsorbed	5,000E+4	5,000E+4	1,0000
HAO - Low with H2PO4- adsorbed	5,000E+4	5,000E+4	1,0000
HAO - Aged	5,000E+4	5,000E+4	1,0000
P - Bound on aged HMO	5,000E+4	5,000E+4	1,0000
Metal soluble - Magnesium	0	0	1,0000
Metal soluble - Calcium	0	0	1,0000
Metal soluble - Ferric	0	0	1,0000
Metal soluble - Ferrous	0	0	1,0000
Metal soluble - Aluminum	0	0	1,0000
Other Cations (strong bases)	0	0	1,0000
Other Anions (strong acids)	0	0	1,0000
Gas - Dissolved total CO2	0	0	1,0000
User defined - UD1	0	0	1,0000
User defined - UD2	0	0	1,0000
User defined - UD3	5,000E+4	5,000E+4	1,0000
User defined - UD4	5,000E+4	5,000E+4	1,0000
Biomass - Sulfur oxidizing	1,000E+5	1,000E+5	1,0000
Biomass - Sulfur reducing propionic acetogenic	5,000E+4	5,000E+4	1,0000
Biomass - Sulfur reducing acetotrophic	5,000E+4	5,000E+4	1,0000
Biomass - Sulfur reducing hydrogenotrophic	1,000E+5	1,000E+5	1,0000
Gas - Dissolved total sulfides	0	0	1,0000
S - Soluble sulfate	0	0	1,0000
S - Particulate elemental sulfur	5,000E+4	5,000E+4	1,0000
Precipitate - Ferrous sulfide	5,000E+4	5,000E+4	1,0000
CODp - Adsorbed hydrocarbon	5,000E+4	5,000E+4	1,0000
CODs - Degradable volatile ind. #1	0	0	1,0000
CODs - Degradable volatile ind. #2	0	0	1,0000
CODs - Degradable volatile ind. #3	0	0	1,0000
CODs - Soluble hydrocarbon	0	0	1,0000
Gas - Dissolved oxygen	0	0	1,0000



Effective diffusivities [m²/s]

Name	Default	Value	
Biomass - Ordinary heterotrophic	5,000E-14	5,000E-14	1,0290
Biomass - Methylothetic	5,000E-14	5,000E-14	1,0290
Biomass - Ammonia oxidizing	5,000E-14	5,000E-14	1,0290
Biomass - Nitrite oxidizing	5,000E-14	5,000E-14	1,0290
Biomass - Anaerobic ammonia oxidizing	5,000E-14	5,000E-14	1,0290
Biomass - Phosphorus accumulating	5,000E-14	5,000E-14	1,0290
Biomass - Propionic acetogenic	5,000E-14	5,000E-14	1,0290
Biomass - Acetoclastic methanogenic	5,000E-14	5,000E-14	1,0290
Biomass - Hydrogenotrophic methanogenic	5,000E-14	5,000E-14	1,0290
Biomass - Endogenous products	5,000E-14	5,000E-14	1,0290
CODp - Slowly degradable particulate	5,000E-14	5,000E-14	1,0290
CODp - Slowly degradable colloidal	5,000E-10	5,000E-10	1,0290
CODp - Degradable external organics	5,000E-14	5,000E-14	1,0290
CODp - Undegradable non-cellulose	5,000E-14	5,000E-14	1,0290
CODp - Undegradable cellulose	5,000E-14	5,000E-14	1,0290
N - Particulate degradable organic	5,000E-14	5,000E-14	1,0290
P - Particulate degradable organic	5,000E-14	5,000E-14	1,0290
N - Particulate degradable external organics	5,000E-14	5,000E-14	1,0290
P - Particulate degradable external organics	5,000E-14	5,000E-14	1,0290
N - Particulate undegradable	5,000E-14	5,000E-14	1,0290
P - Particulate undegradable	5,000E-14	5,000E-14	1,0290
CODp - Stored PHA	5,000E-14	5,000E-14	1,0290
P - Releasable stored polyP	5,000E-14	5,000E-14	1,0290
P - Unreleasable stored polyP	5,000E-14	5,000E-14	1,0290
CODs - Complex readily degradable	6,900E-10	6,900E-10	1,0290
CODs - Acetate	1,240E-9	1,240E-9	1,0290
CODs - Propionate	8,300E-10	8,300E-10	1,0290
CODs - Methanol	1,600E-9	1,600E-9	1,0290
Gas - Dissolved hydrogen	5,850E-9	5,850E-9	1,0290
Gas - Dissolved methane	1,963E-9	1,963E-9	1,0290
N - Ammonia	2,000E-9	2,000E-9	1,0290
N - Soluble degradable organic	1,370E-9	1,370E-9	1,0290
Gas - Dissolved nitrous oxide	1,607E-9	1,607E-9	1,0290
N - Nitrite	2,980E-9	2,980E-9	1,0290
N - Nitrate	2,980E-9	2,980E-9	1,0290
Gas - Dissolved nitrogen	1,900E-9	1,900E-9	1,0290
P - Soluble phosphate	2,000E-9	2,000E-9	1,0290

CODs - Undegradable	6,900E-10	6,900E-10	1,0290
N - Soluble undegradable organic	6,850E-10	6,850E-10	1,0290
Influent inorganic suspended solids	5,000E-14	5,000E-14	1,0290
Precipitate - Struvite	5,000E-14	5,000E-14	1,0290
Precipitate - Brushite	5,000E-14	5,000E-14	1,0290
Precipitate - Hydroxy - apatite	5,000E-14	5,000E-14	1,0290
Precipitate - Vivianite	5,000E-14	5,000E-14	1,0290
HFO - High surface	5,000E-14	5,000E-14	1,0290
HFO - Low surface	5,000E-14	5,000E-14	1,0290
HFO - High with H2PO4- adsorbed	5,000E-14	5,000E-14	1,0290
HFO - Low with H2PO4- adsorbed	5,000E-14	5,000E-14	1,0290
HFO - Aged	5,000E-14	5,000E-14	1,0290
HFO - Low with H+ adsorbed	5,000E-14	5,000E-14	1,0290
HFO - High with H+ adsorbed	5,000E-14	5,000E-14	1,0290
HAO - High surface	5,000E-14	5,000E-14	1,0290
HAO - Low surface	5,000E-14	5,000E-14	1,0290
HAO - High with H2PO4- adsorbed	5,000E-14	5,000E-14	1,0290
HAO - Low with H2PO4- adsorbed	5,000E-14	5,000E-14	1,0290
HAO - Aged	5,000E-14	5,000E-14	1,0290
P - Bound on aged HMO	5,000E-14	5,000E-14	1,0290
Metal soluble - Magnesium	7,200E-10	7,200E-10	1,0290
Metal soluble - Calcium	7,200E-10	7,200E-10	1,0290
Metal soluble - Ferric	4,800E-10	4,800E-10	1,0290
Metal soluble - Ferrous	4,800E-10	4,800E-10	1,0290
Metal soluble - Aluminum	4,800E-10	4,800E-10	1,0290
Other Cations (strong bases)	1,440E-9	1,440E-9	1,0290
Other Anions (strong acids)	1,440E-9	1,440E-9	1,0290
Gas - Dissolved total CO2	1,960E-9	1,960E-9	1,0290
User defined - UD1	6,900E-10	6,900E-10	1,0290
User defined - UD2	6,900E-10	6,900E-10	1,0290
User defined - UD3	5,000E-14	5,000E-14	1,0290
User defined - UD4	5,000E-14	5,000E-14	1,0290
Biomass - Sulfur oxidizing	5,000E-14	5,000E-14	1,0290
Biomass - Sulfur reducing propionic acetogenic	5,000E-14	5,000E-14	1,0290
Biomass - Sulfur reducing acetotrophic	5,000E-14	5,000E-14	1,0290
Biomass - Sulfur reducing hydrogenotrophic	5,000E-14	5,000E-14	1,0290
Gas - Dissolved total sulfides	1,530E-9	1,530E-9	1,0290
S - Soluble sulfate	2,130E-10	2,130E-10	1,0290
S - Particulate elemental sulfur	5,000E-14	5,000E-14	1,0290
Precipitate - Ferrous sulfide	5,000E-14	5,000E-14	1,0290
CODp - Adsorbed hydrocarbon	5,000E-14	5,000E-14	1,0290



CODs - Degradable volatile ind. #1	7,240E-10	7,240E-10	1,0290
CODs - Degradable volatile ind. #2	8,900E-10	8,900E-10	1,0290
CODs - Degradable volatile ind. #3	7,960E-10	7,960E-10	1,0290
CODs - Soluble hydrocarbon	7,120E-10	7,120E-10	1,0290
Gas - Dissolved oxygen	2,500E-9	2,500E-9	1,0290

EPS Strength coefficients []

Name	Default	Value	
Biomass - Ordinary heterotrophic	1,0000	1,0000	1,0000
Biomass - Methylothetic	1,0000	1,0000	1,0000
Biomass - Ammonia oxidizing	5,0000	5,0000	1,0000
Biomass - Nitrite oxidizing	25,0000	25,0000	1,0000
Biomass - Anaerobic ammonia oxidizing	10,0000	10,0000	1,0000
Biomass - Phosphorus accumulating	1,0000	1,0000	1,0000
Biomass - Propionic acetogenic	1,0000	1,0000	1,0000
Biomass - Acetoclastic methanogenic	1,0000	1,0000	1,0000
Biomass - Hydrogenotrophic methanogenic	1,0000	1,0000	1,0000
Biomass - Endogenous products	1,0000	1,0000	1,0000
CODp - Slowly degradable particulate	1,0000	1,0000	1,0000
CODp - Slowly degradable colloidal	1,0000	1,0000	1,0000
CODp - Degradable external organics	1,0000	1,0000	1,0000
CODp - Undegradable non-cellulose	1,0000	1,0000	1,0000
CODp - Undegradable cellulose	1,0000	1,0000	1,0000
N - Particulate degradable organic	1,0000	1,0000	1,0000
P - Particulate degradable organic	1,0000	1,0000	1,0000
N - Particulate degradable external organics	1,0000	1,0000	1,0000
P - Particulate degradable external organics	1,0000	1,0000	1,0000
N - Particulate undegradable	1,0000	1,0000	1,0000
P - Particulate undegradable	1,0000	1,0000	1,0000
CODp - Stored PHA	1,0000	1,0000	1,0000
P - Releasable stored polyP	1,0000	1,0000	1,0000
P - Unreleasable stored polyP	1,0000	1,0000	1,0000
CODs - Complex readily degradable	0	0	1,0000
CODs - Acetate	0	0	1,0000
CODs - Propionate	0	0	1,0000
CODs - Methanol	0	0	1,0000
Gas - Dissolved hydrogen	0	0	1,0000
Gas - Dissolved methane	0	0	1,0000



N - Ammonia	0	0	1,0000
N - Soluble degradable organic	0	0	1,0000
Gas - Dissolved nitrous oxide	0	0	1,0000
N - Nitrite	0	0	1,0000
N - Nitrate	0	0	1,0000
Gas - Dissolved nitrogen	0	0	1,0000
P - Soluble phosphate	0	0	1,0000
CODs - Undegradable	0	0	1,0000
N - Soluble undegradable organic	0	0	1,0000
Influent inorganic suspended solids	0,3300	0,3300	1,0000
Precipitate - Struvite	1,0000	1,0000	1,0000
Precipitate - Brushite	1,0000	1,0000	1,0000
Precipitate - Hydroxy - apatite	1,0000	1,0000	1,0000
Precipitate - Vivianite	1,0000	1,0000	1,0000
HFO - High surface	1,0000	1,0000	1,0000
HFO - Low surface	1,0000	1,0000	1,0000
HFO - High with H2PO4- adsorbed	1,0000	1,0000	1,0000
HFO - Low with H2PO4- adsorbed	1,0000	1,0000	1,0000
HFO - Aged	1,0000	1,0000	1,0000
HFO - Low with H+ adsorbed	1,0000	1,0000	1,0000
HFO - High with H+ adsorbed	1,0000	1,0000	1,0000
HAO - High surface	1,0000	1,0000	1,0000
HAO - Low surface	1,0000	1,0000	1,0000
HAO - High with H2PO4- adsorbed	1,0000	1,0000	1,0000
HAO - Low with H2PO4- adsorbed	1,0000	1,0000	1,0000
HAO - Aged	1,0000	1,0000	1,0000
P - Bound on aged HMO	1,0000	1,0000	1,0000
Metal soluble - Magnesium	0	0	1,0000
Metal soluble - Calcium	0	0	1,0000
Metal soluble - Ferric	0	0	1,0000
Metal soluble - Ferrous	0	0	1,0000
Metal soluble - Aluminum	0	0	1,0000
Other Cations (strong bases)	0	0	1,0000
Other Anions (strong acids)	0	0	1,0000
Gas - Dissolved total CO2	0	0	1,0000
User defined - UD1	0	0	1,0000
User defined - UD2	0	0	1,0000
User defined - UD3	1,0000	1,0000	1,0000
User defined - UD4	1,0000	1,0000	1,0000
Biomass - Sulfur oxidizing	1,0000	1,0000	1,0000
Biomass - Sulfur reducing propionic acetogenic	1,0000	1,0000	1,0000



Biomass - Sulfur reducing acetotrophic	1,0000	1,0000	1,0000
Biomass - Sulfur reducing hydrogenotrophic	1,0000	1,0000	1,0000
Gas - Dissolved total sulfides	0	0	1,0000
S - Soluble sulfate	0	0	1,0000
S - Particulate elemental sulfur	1,0000	1,0000	1,0000
Precipitate - Ferrous sulfide	1,0000	1,0000	1,0000
CODp - Adsorbed hydrocarbon	1,0000	1,0000	1,0000
CODs - Degradable volatile ind. #1	0	0	1,0000
CODs - Degradable volatile ind. #2	0	0	1,0000
CODs - Degradable volatile ind. #3	0	0	1,0000
CODs - Soluble hydrocarbon	0	0	1,0000
Gas - Dissolved oxygen	0	0	1,0000

